

TRUSS DESIGN PROCEDURES AND SPECIFICATIONS  
FOR LIGHT METAL PLATE CONNECTED WOOD TRUSSES  
Limit States Design

**TPIC - 2011**

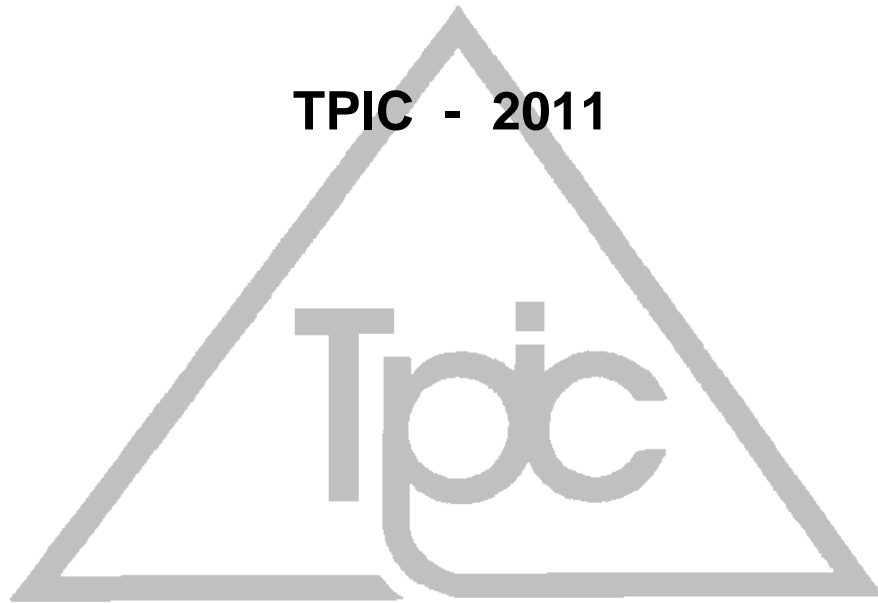

Truss Plate Institute of Canada

TRUSS PLATE INSTITUTE OF CANADA (TPIC)

**Full Members:**

Alpine Systems Corporation  
1701 Creditstone Rd.  
Concord, Ontario  
L4K 5V6

MiTek Canada, Inc.  
100 Industrial Road  
Bradford, Ontario  
L3Z 2B7

London Roof Truss Inc.  
1941 Gore Road  
London, Ontario  
N5W 6B9

Systemes ForeTruss Inc.  
179 Blvd De L'Aeroport  
Gatineau, Quebec  
J8P 7G7

**Affiliate Members :**

AQFSB  
PO Box 1010  
Victoriaville, Québec  
G6P 8Y1

AWTFA  
989, Route 605  
Maple Ridge, New Brunswick  
E6E 1W7

OWTFA  
c/o Kent Trusses  
102 Commerce Park Drive  
Barrie, Ontario  
L4N 8W8

WWTABC  
3187 Caulfield Ridge  
Coquitlam, British Columbia  
V3E 3P7

WWTA-MB, SK  
370 Laurel Bay  
Oakbank, Manitoba  
R0E 1J1

WWTAA  
212, 3916 – 64<sup>th</sup> Ave SE  
Calgary, Alberta  
T2C 2B4

**Associated Members :**

Stracon Engineering Inc.  
69 Graydon Cres.,  
Richmond Hill, Ontario  
L4B 3W7

Taiga Building Products  
520 Harrop Drive  
Milton, Ontario  
L9T 3H2

USP Canada  
221 Racco Parkway  
Thornhill, Ontario  
L4J 8X9

Etruss Engineering  
160 Empress Ave  
Toronto, Ontario  
L4J 9H1

Simpson Strong-Tie Canada, Ltd.  
11476 Kingston Street  
Maple Ridge, British Columbia  
V2X 0Y5

Boise Cascade – Engineered Wood  
Products  
333 Jolliffe Avenue  
Rockwood, Ontario  
N0B 2K0

**DISCLAIMER**

These recommendations are for the design of metal plate connected wood trusses that originate from the collective experience of leading technical personnel in the metal plate connected wood truss industry, but must, due to the nature of the responsibilities involved, be presented only as a guide for the use of a qualified engineer or designer. By publishing this booklet, the Truss Plate Institute of Canada and its member companies do not warrant the recommendations information contained herein as proper under all conditions and expressly disclaim any responsibility for damages arising from the use, application, or reliance on the recommendations and information contained herein. This standard does not preclude the use of materials, assemblies, structures or designs not meeting the criteria herein, when they demonstrate equivalent performance for the intended use to those specified in this standard.

## FOREWARD

The purpose of this manual is to present data for design to those familiar with engineering procedures. It does not include information found in standard engineering textbooks which include derivation of formulas. It is not intended that these specifications illustrate all truss configurations or details thereof.

This specification covers materials, both lumber and steel, design procedures for members and joints, including minimum snow loads and minimum dead loads, and evaluation of connector plates.

This specification incorporates the most recent code changes, lumber and design standards and the latest generally accepted engineering procedures and methods. All previous editions of this specification are obsolete.

These specifications do not cover design for the complete structural system of a building. Suitable provisions must be made for adequate supports, cross bracing, wind loading, seismic loading, or other horizontal loading by those responsible for over-all building design.

The design methods contained within this specification are based on sound engineering judgement with specific reference to the Canadian Standards Association (CSA O86-09) and the National Building Code of Canada 2010. A continuous program of research work is being carried out at various universities and testing laboratories to supplement and enhance this specification.

The purpose of the Truss Plate Institute of Canada is; to serve the needs of manufacturers of truss plates and wood trusses by representation on various committees of recognized organizations dealing with building codes and standards; to establish and promulgate standards for the design, manufacture and quality control of truss plates as may be required; to do all other things to foster and develop truss plate manufacturing and wood truss fabrication industries, consistent with law, and in the mutual interest of members of the organization.

## HISTORY OF TPIC

**Year 1971** National Building Code of Canada (1970) introduced new classifications and dimensions for lumber construction.

**June 1971** Several major Canadian truss plate manufacturers convened for the purpose of creating the Truss Plate Institute of Canada.

**May 1972** TPIC was incorporated under Canadian law and its constitution and by-laws adopted.

**July 1973** Uniform testing procedures for metal truss plates were developed.

**April 1974** CMHC and TPIC agreed on maximum span tables for publication in N.B.C.C.

**Oct 1976** TPIC Testing procedures for truss plates were adopted as CSA Standard S347.

**May 1977** CMHC recognized TPIC Design Procedures.

**Jan 1981** 3rd Edition of TPIC Design Procedure for Roof and Floor Trusses published.

**Jan 1988** 4th Edition of TPIC Design Procedure for Roof and Floor Trusses published.

**1988 - 1995** A number of addendums, revisions and additional design procedures were added to TPIC 1988 to keep the industry abreast of the latest technical information.

**June 2011**

**Nov 1995** The publication, printing and distribution of the National Building Code of Canada introduces Reliability Based design procedures (Limit States design procedures). With Working Stress design procedures to be eliminated, truss testing at Forintek in Vancouver took place through 1993-1995.

**Fall 1997** TPIC 1996 is published introducing truss design procedures and specifications for light metal plate connected wood trusses for Limit States Design.

**Fall 2005** The publication, printing and distribution of the National Building Code of Canada brings about changes in loading Considerations

**June 2007** TPIC 2007 is published updating the document to incorporate changes brought about by NBCC 2005 and considerations for OBC 2006.

**2007 - 2011** A number of addendums, revisions and additional design procedures were added to TPIC 2007 to keep the industry abreast of the latest technical information.

**June 2011** TPIC 2011 is published updating the document to incorporate the various addendums and revisions.

## DESIGN RESPONSIBILITIES

**Truss Designer/Engineer** - a design professional, individual or organization having responsibility for the design of individual metal plate connected wood truss components, including lateral bracing requirements to prevent buckling of individual truss members due to specified loads.

**Building Designer/Engineer** - a design professional, individual or organization, having responsibility for overall building design. Within the scope of wood trusses, the building designer / engineer, shall specify the following:

- (a) Design loads in accordance with various sections of the National and / or Provincial Building Codes.
- (b) Truss profile and intended support locations.
- (c) Vertical and horizontal deflection limits.
- (d) Moisture environment for intended end use.
- (e) Any special requirements to be considered in the truss design.
- (f) Additional loads from mechanical, electrical units, which may induce extra load to various truss members and their locations.

As this standard does not cover the design for the complete structural system of a building, the building designer / engineer shall provide the following in the design and detailing of the building:

- (a) Truss supports and anchorage accommodating horizontal, vertical or other reaction or displacement.
- (b) Permanent truss bracing to resist wind, seismic and any other lateral forces acting parallel or perpendicular to the plane of trusses.
- (c) Method of connection or anchorage of mechanical, electrical units to various truss members.

## CONTENTS

<b>1. GENERAL</b>	<b>1</b>
1.1 DEFINITIONS	1
1.2 ABBREVIATIONS	2
1.3 REFERENCE PUBLICATOINS	3
<b>2. MATERIALS</b>	<b>4</b>
2.1 LUMBER SIZES AND GRADES	4
2.2 STEEL	4
<b>3. GENERAL DESIGN</b>	<b>6</b>
3.1 SPECIFIED LOADS, LOAD EFFECTS AND LOAD COMBINATIONS	6
3.1.1 Buildings	6
3.1.2 Specified Loads	6
3.1.2.1 Loads to be Considered	6
3.1.2.2 Importance Category	7
3.1.2.3 Importance Factors	7
3.1.3 Load Combinations	8
3.1.3.1 Load Combinations for Ultimate Limit States	8
3.1.3.2 Load Combinations for Serviceability Limit States	8
3.2 SPECIFIED SNOW, LIVE AND WIND LOADS	9
3.2.1 Roof Trusses – Housing and Small Buildings (Part 9 of NBCC10)	9
3.2.2 Roof Trusses (Part 4 of NBCC10)	9
3.2.3 Low Human Occupancy (Farm)	10
3.2.4 Floor Trusses – Housing and Small Buildings (Part 9 of NBCC10)	10
3.2.5 Floor Trusses (Part 4 of NBCC10)	10
3.3 SPECIFIED DEAD LOADS	11
3.3.1 Roof Dead Loads	11
3.3.2 Floor Dead Loads	11
<b>4. MEMBER DESIGN PROCEDURE</b>	<b>12</b>
4.1 ANALOGUE	12
4.1.1 Analogue Joint Types	12
4.1.2 Analogue Points	12
4.1.3 Analogue Modifications	14
4.2 ULTIMATE LIMIT STATES	23
4.2.1 Method of Analysis	23
4.2.2 Ultimate Limit States	23
4.3 SPECIFIED STRENGTHS	24
4.3.1 Visually Stress-Graded Lumber	24
4.3.2 Machine Stress-Rated and Machine Evaluated Lumber	24
4.3.3 Design Specified Strengths	24
4.3.4 Modification Factors	24
4.4 STRENGTH RESISTANCE	27
4.4.1 Bending Moment Resistance	27
4.4.2 Shear Resistance	27
4.4.3 Compressive Resistance Parallel To Grain	28
4.4.4 Compressive Resistance Perpendicular To Grain	29
4.4.5 Tensile Resistance Parallel To Grain	30
4.4.6 Stress Index Due To Bending	30
4.4.7 Stress Index Due To Shear	30
4.4.8 Stress Index To Compression (Parallel to Grain)	31

4.4.9	Stress Index Due To Compression (Perpendicular to Grain)	31
4.4.10	Stress Index Due To Tension	31
4.4.11	Combined Stress Index Due To Tension & Bending	31
4.4.12	Combined Stress Index Due To Compression & Bending	31
4.4.13	Combined Stress Index Due To Compression & Bending (Modified Formula)	31
4.5	<b>SERVICEABILITY LIMIT STATES</b>	<b>33</b>
4.5.1	Serviceability Requirements (Allowable Deflections)	33
4.5.2	Permanent Deformation	34
4.5.3	Ponding	34
4.6	<b>SPECIAL DESIGN CONSIDERATIONS</b>	<b>35</b>
4.6.1	Overhangs	35
4.6.2	Splices	35
4.6.3	Short Cantilevers and Heel Cuts	36
4.6.4	Girder Trusses (Single and Multi-Ply)	36
4.6.5	Truss Bracing	36
4.6.6	Top Chord Bearing Guidelines	36
<b>5.</b>	<b>JOINT DESIGN PROCEDURES</b>	<b>37</b>
5.1	GENERAL	37
5.2	CONNECTOR PLATE EVALUATION	38
5.3	STRENGTH LIMIT STATES	39
5.3.1	General	39
5.3.2	Modification Factors	39
5.3.3	Ultimate Lateral Resistance	39
5.3.4	Tensile Resistance	40
5.3.5	Shear Resistance	40
5.3.6	Factored Resistance of Truss Plates	41
5.4	SERVICEABILITY LIMIT STATES	41
5.5	MEMBER JOINT CONNECTION	42
5.5.1	Connection of Tension Members	42
5.5.2	Connection of Compression Members	42
5.5.3	Connection of Members for Shear	42
5.5.4	Combined Shear-Tension Resistance	42
5.5.5	Net Section Lumber Check (h')	43
5.5.6	Tension Perpendicular-to-Grain Considerations	44
5.5.7	Heel Joint Considerations	44
5.5.8	Chord Member Splice Considerations	45
5.5.8.1	General	45
5.5.8.2	Tension Splices	45
5.5.8.3	Compression Splices	45
5.5.8.4	Moment Considerations	46
5.5.8.4.1	Design of Steel Section for Effect of Moment	46
5.5.8.4.2	Design of Plate Lateral Resistance for Effect of Moment	47
5.5.9.	Compression Perpendicular-to-Grain	48
<b>6.</b>	<b>MANUFACTURING AND MATERIAL VARIANCES</b>	<b>49</b>
<b>7.</b>	<b>TRUSS DESIGN DRAWING</b>	<b>49</b>

## APPENDIX

### Appendix A

A.1	Short Cantilevers: Detail without Reinforcing	50
A.2	Short Cantilevers: Detail with Wedge Reinforcing	51
A.3	Short Cantilevers: Detail with Partial Top Chord Reinforcing	52
A.4	Short Cantilevers: Detail with Partial Bottom Chord Reinforcing	53
A.5	Heel Cuts	54
A.6	Supplementary Notes for Design of Short Cantilevers and Heel Cuts	55

### Appendix B

B.1	Truss-to-Truss Connection	56
B.1.1	Nail Spacing and Maximum Number of Rows	56
B.1.2	Maximum kN/m (PLF) for 2 Ply Girder	57
B.1.3	Maximum kN/m (PLF) for 3 Ply Girder	58
B.1.4	Maximum kN/m (PLF) for 4 Ply Girder	59
B.1.5	Maximum kN/m (PLF) for 5 Ply Girder	60

### Appendix C

C.1	Maximum Web Force in Compression kN (lb) with One T-brace	61
-----	---	----

### Appendix D

D.1	Top Chord Bearing Joint Guidelines for Lumber on Edge	62
D.2	Top Chord Bearing Joint Guidelines for Lumber on Flat	64

### Appendix E

E.1	Corrosion Protection for Metal Connector Plates	67
-----	---	----

### Appendix F

F.1	Shear Plate Design for Girder Type Heel Joint	68
-----	---	----

### Appendix G

	Manufacturing And Material Variances	70
G.1	Scope	70
G.2	Truss shop drawing	70
G.3	Materials	70
G.3.1	Lumber	70
G.3.2	Metal connector plates	70
G.4	Plating	70
G.4.1	Tooth effectiveness	70
G.4.2	Plate placement tolerances	73
G.5	Truss Assembly	74
G.5.1	Member to member gaps	74
G.5.2	Overall truss dimensions	75

### Appendix H

H.1	Minimum information on truss design drawing	76
-----	---	----

## ILLUSTRATIONS

**Figures**

4.1.2	Simple and Compound Analogue	15
4.1.2.1.A	Standard Heel Analogue	16
4.1.2.1.B	Girder Heel	16
4.1.2.1.C	Raised Heels	17
4.1.2.1.D	Short Cantilevered Heels	18
4.1.2.1.E	Short Cantilevered Heels	19
4.1.2.1.F	Short Cantilevered Heels	19
4.1.2.1.G	Short Cantilevered Heels	19
4.1.2.2	Pitch Break Joint	20
4.1.2.2.A	Mitre Cut Pitch Break Joint	20
4.1.2.2.B	Corner Joint	20
4.1.2.3	Splice Joint	21
4.1.2.4	Lapped Joint	21
4.1.2.5	Web Joints	21
4.1.2.6	Internal Joint	21
4.1.2.7	Tail Bearing Joint	21
4.1.2.8	Top Chord Bearing Details	22
4.1.2.9	Top Chord Bearing with End Vertical and Block	22
4.5.1.(4)	Truss Deflection Lengths	33
4.6.2.(2)	Kingpost and Queenpost Truss Configurations	35
5.1.(5)	Truss Plate Load and Grain Orientation	40
5.5.4	Shear - Tension Lengths and Angles	43
5.5.5	Typical h' Dimensions	44
5.5.9	Bearing Reinforcement with Connector Plates	48

**Tables**

2.2.(1)	ASTM Specification A653/A653M for Structural Quality Sheet Steel	4
3.1.2.2	Importance Categories for Buildings	7
3.1.2.3	Importance Factors for Determining S,W or E	7
3.1.3.1	Load Combinations for Ultimate Limit States	8
3.1.3.2	Load Combinations for Serviceability Limit States	8
3.3.1	Minimum Dead Loads	11
4.3.4.(1)	Load Duration Factor, $K_D$	24
4.3.4.(2)	Service Condition Factor, $K_S$	25
4.3.4.(3)	Treatment Factor, $K_T$	25
4.3.4.(4)	System Factor, $K_H$	26
4.3.4.(5)	Size Factor, $K_Z$ for Visually Graded Lumber	26
4.4.1.(2)	Lateral Stability Factor, $K_L$	27
4.4.4.(4)	Size Factor for Bearing, $K_{ZCP}$	30
4.4.4.(5)	Length of Bearing Factor, $K_B$	30
4.5.1.(4)	Truss Deflection Limitations	34
5.1.(7)	Minimum Bite for Chords and Webs	38
5.3.2.(2)	Service Condition Factor, $K_{SF}$	39
5.5.7.(1)	Heel Joint Moment Factor, $J_H$	44

## 1. GENERAL

### 1.1 DEFINITIONS

BEARING	The structural support of the truss, usually load bearing walls, support beams, or truss hangers.
BOTTOM CHORD	A horizontal or inclined lumber member that establishes the lower edge of a truss.
CANTILEVER	The top and bottom chord section of a truss that extends freely beyond an exterior support.
CLEAR SPAN	The truss length measured from inside face to inside face of adjacent supports.
COMPANION LOAD	A specified variable load that accompanies the principal load in a given load combination.
COMPANION LOAD FACTOR	A factor that, when applied to a companion load in the load combination, gives the probable magnitude of a companion load acting simultaneously with the factored principal load.
CONTINUOUS SHEATHING	The application of sheathing material to a truss chord, usually by nailing, such that the chord is in effect laterally braced continuously along its length.
DESIGN SPAN	The overall length of the truss analogue used in the structural analysis.
DRY SERVICE	A condition in which the average equilibrium moisture content over a year is 15% or less and does not exceed 19%.
HEEL JOINT	A joint on a truss at which the top and bottom chords intersect.
HEEL CUT	At the heel joint, a vertical cut at the outside edge of the truss bottom chord made to define design span.
LOAD SHARING SYSTEMS	A system consisting of 3 or more essentially parallel trusses spaced not more than 610 mm (1220 mm for Low Human Occupancy) apart and so arranged that they mutually support the applied load.
LOW HUMAN OCCUPANCY	(As applying to farm buildings) A building with an occupant load of not more than one person per 40 sq m during normal use.
LUMBER ON EDGE	Orientation of truss lumber such that the chord sheathing is applied to the least chord dimension and connector plates are embedded into the wider chord dimension.
LUMBER ON FLAT	Orientation of truss lumber such that chord sheathing is applied to the wider chord dimension and connector plates are embedded into the least chord dimension.
OVERHANG	The outward extension of one truss chord (usually the top chord), beyond the other chord (usually the bottom chord).

PANEL JOINT	The point of intersection where one or more webs meet the top or bottom chord.
PITCH BREAK	The point at which truss chord lumber changes slopes.
PRINCIPAL LOAD	The specified variable load or rare load that dominates in a given load combination.
PRINCIPAL LOAD FACTOR	A factor applied to a principal load in a load combination to account for the variability of the load and load pattern and the analysis of its effects.
SCISSOR TRUSS	A type of truss having an inclined bottom chord.
SERVICE LOAD	The specified load used for the evaluation of a serviceability limit state.
SEASONED LUMBER	Lumber, which has been seasoned to approximately 15% moisture content to a depth of 20mm from the surface. For plating purposes, at the time of fabrication, seasoned lumber will be that which has moisture content of 19% or less as per CSA S347.
SLOPE	The ratio of vertical rise to horizontal run for inclined members.
SPLICE JOINT	The joint at which two chord members are joined together with truss connector plates to form a single member.
TOP CHORD	Horizontal or inclined lumber member that establishes the upper edge of a truss.
UNSEASONED LUMBER	Lumber of which the moisture content exceeds the requirements of seasoned lumber.
WEBS	Internal truss members that join the top and bottom chords to form triangular patterns that give truss action by carrying axial stresses.
WET SERVICE	Service conditions other than dry.

## 1.2 ABBREVIATIONS

ASTM	American Society for Testing and Materials
NFBCC 95	National Farm Building Code of Canada 1995
CCMC	Canadian Construction Materials Centre - National Research Council Canada, Institute for Research in Construction
O86-09	CSA O86-09 Engineering Design in Wood
HSB	Housing and Small Buildings
LHO	Farm - Low Human Occupancy

NBCC10	National Building Code of Canada 2010
NBCC10 (ST.COMM)	National Building Code of Canada 2010, Users Guide and Structural Commentaries
NLGA	National Lumber Grades Authority
NRCC	National Research Council of Canada
TPIC	Truss Plate Institute of Canada

### 1.3 REFERENCE PUBLICATIONS

ASTM A653 / A653M	“Specification for Steel Sheet, Zinc-Coated (Galvanized) or Zinc - Iron Alloy - Coated (Galvannealed) by the Hot-Dip Process.”
ASTM A924 / A924M	“Specification for General Requirements for Steel Sheet, Metallic - Coated by the Hot - Dip Process.”
BCSI	Wood Truss Council of America “Building Component Safety Information”
CSA O86-09	Canadian Standards Association Publication “086-09 Engineering Design in Wood (Limit States Design)”
S347-99	Canadian Standards Association Publication “S347-99 Method of Test for Evaluation of Truss Plates Used in Lumber Joints”
NFBCC 1995	National Research Council of Canada Publication "National Farm Building Code of Canada 1995"
NBCC 2010	National Research Council of Canada Publication “National Building Code of Canada 2010”
NBCC10 (ST.COMM.)	National Research Council of Canada Publication, “National Building Code of Canada 2010, Users Guide and Structural Commentaries”
TPIC 1996	Truss Design Procedures and Specifications for Light Metal Plate Connected Wood Trusses Limit States Design, 1996 edition
TPIC 2007	Truss Design Procedures and Specifications for Light Metal Plate Connected Wood Trusses Limit States Design, 2007 edition

**2. MATERIALS**

**2.1 LUMBER SIZES AND GRADES**

- 1) Net section properties shall be used for all truss designs.
- 2) Minimum nominal chord size for all trusses shall be 38 x 64 except for trusses used in mobile homes.
- 3) All trusses shall be manufactured using lumber graded by NLGA rules, with specified strengths as per O86-09.
- 4) All trusses shall be manufactured with No. 2 grade lumber or better for top and bottom chords.
- 5) All truss webs, except as those described in 2.1.6, shall be designed with any lumber grade provided the grade is listed and assigned a specified strength in O86-09.
- 6) Truss webs of 38 x 64 lumber shall be No. 2 grade or better.

**2.2 STEEL**

- 1) Truss Plates shall be manufactured from galvanized sheet steel conforming to or exceeding ASTM Standard A653/A653M “Standard specification for Sheet Steel, Zinc coated (Galvanized) by the Hot-Dip Process” and shall have the minimum properties specified in Table 2.2(1).

Table 2.2(1) ASTM Specification A653/A653M for Structural Sheet Steel

GRADE	SS230	SS255	SS275	HSLAS340	HSLAS410
Ultimate Tensile Strength, MPa	310	360	380	410	480
Minimum Yield, MPa	230	255	275	340	410
Elongation (at failure) in 50 mm length, %	20	18	16	20	16

- 2) Corrosion resistant coating shall conform to ASTM A924, “Standard Specification for Steel Sheet, Zinc-Coated (Galvanized) by the Hot-Dip Process, General Requirements”, Coating Designation G90, or ASTM A924, “Standards Specification for Electrolytic Zinc-Coated Steel Sheets”, Coating Class C, or such treatment as will give equivalent corrosion protection as applied to steel sheet before connector plates are stamped out. It is not necessary to re-coat connectors after stamping.
- 3) On metal connector plates there shall be provided some means such as holes, dimples, bosses, marked pattern, etc., to indicate location of any separately applied nails or fasteners so that nails or fasteners will not be spaced too closely together in the wood and cause excessive splitting. Plate Designer shall determine this nail or fastener minimum spacing. Blank metal plates without any type of indicated minimum spacing for nails or fasteners shall not be acceptable. The above applies only where supplementary fasteners are intended to augment the gripping value of plates.

**TRUSS PLATE INSTITUTE OF CANADA (2011)**

- 4) All plate manufacturers must have their plates listed in the Registry of Product Evaluations published by Canadian Construction Materials Centre, Institute for Research in Construction, Ottawa, Ontario.

### **3. GENERAL DESIGN**

#### **3.1 SPECIFIED LOADS, LOAD EFFECTS AND LOAD COMBINATIONS**

##### **3.1.1 Buildings**

The specified loads, load effects and combinations to be considered in the design of a building and its elements shall be those given in Clauses 3.1.2 and 3.1.3.

##### **3.1.2 Specified Loads**

###### **3.1.2.1 Loads to be Considered**

Specified loads shall include the following wherever applicable, and minimum specified values of these loads shall be increased to account for dynamic effects where applicable:

- (1) D --- dead load due to weight of members; the weight of all materials of construction incorporated into the building to be supported permanently by the member, including permanent partitions and allowance for nonpermanent partitions; the weight of permanent equipment;
- (2) E --- load due to earthquake including the effect of the importance factors in 3.1.2.2;
- (3) L --- live load due to intended use and occupancy including loads due to cranes and pressure of liquids in containers;
- (4) S --- load due to snow, including ice and associated rain, and also including the effect of the importance factors in 3.1.1.2;
- (5) W --- load due to wind including the importance factors in 3.1.2.2;
- (6) H --- a permanent load due to lateral earth pressure, including groundwater;
- (7) P --- permanent effects caused by prestress; and
- (8) T --- loads due to contraction or expansion caused by temperature changes, shrinkage, moisture changes, creep in component materials, movement due to differential settlement, or combinations thereof.

###### **3.1.2.2 Importance Category**

For the purpose of determining specified loads S, W or E in Section 3.2.1 and 3.2.2, buildings shall be assigned an Importance Category based on intended use and occupancy, in accordance with table 3.1.2.2.

**Table 3.1.2.2**  
**Importance Categories for buildings**

Use and Occupancy	Importance Category
Buildings that represent a low direct or indirect hazard to human life in the event of failure, including: <ul style="list-style-type: none"> <li>▪ Low human-occupancy buildings, where it can be shown that collapse is not likely to cause injury or other serious consequences</li> <li>▪ Minor storage buildings</li> </ul>	Low
All buildings except those listed in Importance Categories Low, High and Post Disaster	Normal
Buildings that are likely to be used as post-disaster shelters, including buildings whose primary use is: <ul style="list-style-type: none"> <li>▪ As an elementary, middle or secondary school</li> <li>▪ As a community centre</li> </ul> Manufacturing and storage facilities containing toxic, explosive or other hazardous substances in sufficient quantities to be dangerous to the public if released.	High
Post-disaster buildings are buildings that are essential to the provision of services in the event of a disaster, and include: <ul style="list-style-type: none"> <li>▪ hospitals, emergency treatment facilities and blood banks</li> <li>▪ telephone exchanges</li> <li>▪ power generating stations and electrical substations</li> <li>▪ control centres for air, land and marine transportation</li> <li>▪ public water treatment and storage facilities, and pumping stations</li> <li>▪ sewage treatment facilities and buildings having critical national defence functions</li> <li>▪ buildings of the following types, unless exempted from this designation by the authority having jurisdiction:                             <ul style="list-style-type: none"> <li>▪ emergency response facilities</li> <li>▪ fire, rescue and police stations, and housing for vehicles, aircraft or boats used for such purposes</li> <li>▪ communications facilities, including radio and television stations</li> </ul> </li> </ul>	Post- disaster

**3.1.2.3 Importance Factors**

For the purpose of determining specified loads S, W, or E in Clause 3.1.2.1, Importance Factors shall be applied in accordance with Table 3.1.2.3

**Table 3.1.2.3**  
**Importance Factors for Determining S,W or E**

Importance Category	Importance Factors for Snow Loads, $I_s$		Importance Factors for Wind Loads, $I_w$		Importance Factors for Earthquake Loads, $I_E$	
	Ultimate Limit State	Serviceability Limit State	Ultimate Limit State	Serviceability Limit State	Ultimate Limit State	Serviceability Limit State
Low	0.8	0.9	0.8	0.75	0.8	N / A
Normal	1.0	0.9	1.0	0.75	1.0	N / A
High	1.15	0.9	1.15	0.75	1.3	N / A
Post Disaster	1.25	0.9	1.25	0.75	1.5	N / A

### 3.1.3 Load Combinations

#### 3.1.3.1 Load Combinations for Ultimate Limit States

The effect of factored principal plus companion loads shall be determined in accordance with the load combinations in Table 3.1.3.1, the applicable combination being that which produces the most unfavourable effect.

**Table 3.1.3.1  
Load Combinations for Ultimate Limit States**

Case No.	Principal Loads <sup>(1)</sup>	Companion Loads
1	1.4D	
2	$(1.25D^{(3)} \text{ or } 0.9D) + 1.5L^{(4)}$	$0.5S^{(2)} \text{ or } 0.4W$
3	$(1.25D^{(3)} \text{ or } 0.9D) + 1.5S$	$0.5L^{(2,5)} \text{ or } 0.4W$
4	$(1.25D^{(3)} \text{ or } 0.9D) + 1.4W$	$0.5L^{(5)} \text{ or } 0.5S$
5	1.0D + 1.0E	$0.5L^{(2,5)} + 0.25S^{(2)}$

Notes:

- (1) Refer to the NBCC, 2010 for loads due to earth pressure H, prestress P and Imposed deformation T.
- (2) Refer to the NBCC, 2010 for loads on exterior areas.
- (3) Refer to the NBCC, 2010 for dead load D for soil.
- (4) The Principal load factor 1.5 for live load L may be reduced to 1.25 for liquids in tanks.
- (5) The companion load factor 0.5 for live load L shall be increased to 1.0 for storage occupancies, equipment areas, service rooms and attic floor areas.

#### 3.1.3.2 Load Combinations for Serviceability Limit States

The effect of principle plus companion loads shall be determined in accordance with the load combinations in Table 3.1.3.2, the applicable combination being that which results in the most unfavourable effect.

**Table 3.1.3.2  
Load Combinations for Serviceability Limit States**

Case No.	Principal Loads	Companion Loads
1	$1.0D^{(1)}$	
2	$1.0D^{(1)} + 1.0L$	$0.5S^{(2)} \text{ or } 0.4W$
3	$1.0D^{(1)} + 1.0S$	$0.5L^{(2)} \text{ or } 0.4W$
4	$1.0D^{(1)} + 1.0W$	$0.5L \text{ or } 0.5S$

Note:

- (1) Dead loads to include permanent loads due to lateral earth pressure H and prestress P.
- (2) Refer to the National Building Code of Canada 2010, for loads on exterior areas.

## **3.2 SPECIFIED SNOW, LIVE AND WIND LOADS**

### **3.2.1 Roof Trusses – Housing and Small Buildings (Part 9 of NBCC10)**

- 1) Roof trusses meeting the housing and small building requirements of Part 9 of the NBCC10, with clear spans between bearings less than or equal to 12.19m, (40 feet) shall be designed using a roof snow load not less than 55% of the appropriate ground snow load plus rain load as listed in the NBCC10 Appendix C. When the entire width of roof does not exceed 4.3m (14 feet) this 55% can be reduced to 45%.
- 2) Roof trusses meeting the housing and small building requirements of Part 9 of the NBCC10, with clear spans between bearings greater than 12.19m (40 feet) shall be designed as per section 3.2.2.
- 3) The minimum specified top chord snow load shall be 1.0 kPa (21 psf)
- 4) Multi-bearing trusses shall be designed for pattern-loading.

### **3.2.2 Roof Trusses (Part 4 of NBCC10)**

- 1) Roof trusses designed under the requirements of Part 4 of NBCC10 shall be designed using a roof snow load not less than 80% of the appropriate ground snow load plus rain load as listed in NBCC10 Appendix C, except where:
  - (a) Wind exposure conditions specified by Section 4.1.6 of NBCC10 are fulfilled, hence 60% of the ground snow load plus rain load may be used as the roof snow load for low and normal building importance, or
  - (b) The roof slope is greater than 30 degrees, hence the roof snow load can be reduced by a slope factor as specified by Section 4.1.6 of NBCC10, or
  - (c) The roof slope is greater than 15 degrees and slippery roof conditions specified by Section 4.1.6 of NBCC10 are fulfilled, hence the roof snow load can be reduced by a slope factor as specified in that Section, or
  - (d) For large roofs the value of  $C_b$  shall be calculated as per NBCC10 4.1.6.2, 2) a) & b).
  - (e) The snow load is specified in writing by an authority having jurisdiction.
- 2) Roof trusses shall be designed to meet the requirements of full and partial loading as specified by Section 4.1.5 and 4.1.6 of NBCC10.
- 3) Roof trusses shall be designed to meet the requirements of unbalanced, sliding and drifting snow loads, as given in Section 4.1.6 of the NBCC10.
- 4) Roof trusses with slopes of 15 degrees or less need not be designed for unbalanced snow loads.
- 5) The minimum specified top chord snow load shall be 1.0 kPa. (21 psf)
- 6) The minimum specified live load for attics with limited accessibility shall be .5 kPa (10 psf) as per Table 4.1.5.3 NBCC10 unless specified otherwise by an authority having jurisdiction.
- 7) Roof trusses shall be designed for wind loading in accordance with Section 4.1.7 NBCC10.
- 8) For wind analysis the minimum reference velocity pressure shall be based on the probability of being exceeded once in 50 years for strength and deflection. Appropriate wind loads are as listed in NBCC10 Division B, Appendix C.

### **3.2.3 Low Human Occupancy (Farm)**

- 1) LHO roof trusses shall be designed using a roof live load not less than 80% of the appropriate ground snow load plus rain load as listed in NBCC95 Appendix C, except where:
  - (a) Wind exposure conditions specified by Section 4.1.7 of NBCC95 are fulfilled, hence 60% of the ground snow load plus rain load may be used as the roof load, or
  - (b) The roof slope is greater than 30 degrees, hence the roof snow load can be reduced by a slope factor as specified by Section 4.1.7 of NBCC95, or
  - (c) The roof slope is greater than 15 degrees and slippery roof conditions specified by Section 2.2.2.2 of NBCC95 are fulfilled, hence the roof snow load can be reduced by a slope factor as specified in that section, or
  - (d) The snow load is specified in writing by an authority having jurisdiction.
- 2) LHO roof trusses shall also be designed to meet the requirements of unbalanced, sliding and drifting snow loads as given in Section 4.1.7 of NBCC95.
- 3) LHO roof trusses referenced in 2.2.2.1 of the NBCC95 with slopes of 15 degrees or less need not be designed for unbalanced snow loads.
- 4) The minimum specified top chord live load shall be 1.0 kPa. (21 psf)
- 5) LHO roof trusses shall be designed for wind load in accordance to Section 4.1.8 of NBCC95.
- 6) For wind analysis of LHO roof trusses the minimum reference velocity pressure shall be based on the probability of being exceeded once in 10 years.

### **3.2.4 Floor Trusses – Housing and Small Buildings (Part 9 of NBCC10)**

- 1) The minimum residential specified floor live load shall be 1.9 kPa. (40 psf)
- 2) Floor trusses must be designed to satisfy the most critical loading conditions of full or partial loading.

### **3.2.5 Floor Trusses (Part 4 of NBCC10)**

- 1) The minimum specified live load for commercial assembly areas that follow the guidelines given in Table 4.1.5.3 of NBCC10 shall be 2.4 kPa. (50 psf)
- 2) The minimum specified live load for commercial assembly areas and/or other areas that follow the guidelines given in Table 4.1.5.3 of NBCC10 shall be 4.8 kPa. (100 psf)
- 3) Floor trusses must be designed to satisfy the most critical loading conditions of full or partial loading.
- 4) The specified load due to possible concentrations of loads resulting from the use of area of floors, shall not be less than that listed in Table 4.1.5.9 of NBCC10.

### 3.3 SPECIFIED DEAD LOADS

#### 3.3.1 Roof Dead Loads

The following minimum dead loads specified in Table 3.3.1 shall be used for all designs unless specified by an authority having jurisdiction.

**Table 3.3.1 Minimum Dead Loads, kPa (psf)**

Occupancy	TC Dead Load		BC Dead Load	
	<1:6 <sup>†</sup> (2/12)	≥1:6 (2/12)	With Ceiling	Without Ceiling
Residential (Part 9)	0.5 (10)	0.15 (3)	0.34 (7)	N/A
Commercial (Part 4)	0.5 (10)	0.25 (5)	0.34 (7)	0.25 (5)
Farm (Part 4)	0.5 (10)	0.20 (4)	0.34 (7)	0.20 (4)

Note: The designer should check the suitability of these minimums for their applications.

<sup>†</sup> This applies to trusses carrying flat roof (where roof portion with slope < 1:6 exceeds 50% of building width).

#### 3.3.2 Floor Dead Loads

- 1) The minimum dead loads specified below shall be used for all designs unless specified otherwise by an authority having jurisdiction.
- 2) The minimum top chord dead load shall be 0.5 kPa (10 psf)
- 3) The minimum bottom chord dead load shall be 0.25 kPa (5 psf)
- 4) In areas of a building where partitions, other than permanent partitions shown on design drawings, or, where partitions might be added in the future, allowance shall be made for the weight of such partitions.

The partition weight allowance for the above shall be determined from the actual or anticipated weight of the partitions placed in any probable position, but shall not be less than 1.0 kPa (21 psf) over the area of floor being considered.

- 5) A non-bearing partition wall may be neglected in the design provided:
  - a) Live load of supporting truss system results from residential occupancy and is not less than specified in 3.2.4.
  - (b) Floor trusses are not spaced over 610 mm o/c (24 in o/c)
  - (c) Top chord panel length of supporting truss system does not exceed 750 mm (30 in) for lumber-on-flat trusses.
  - (d) Partition weight does not exceed 0.88 kN/m (60 plf)
  - (e) Partition wall is not to be parallel to the trusses.

## 4. MEMBER DESIGN PROCEDURE

### 4.1 ANALOGUE

#### 4.1.1 Analogue Joint Types

- (a) Pitch Break Joint: A joint formed by the intersection of two non-parallel chords (see Fig 4.1.2).
- (b) Heel Joint: A pitch break joint consisting of a non-vertical top chord and non-vertical bottom chord (see Fig 4.1.2).
- (c) Splice Joint: A joint formed by two parallel and adjacent chords (see Fig 4.1.2.3).
- (d) Lapped Joint: A joint formed by one end of a chord placed parallel and in contact with the adjacent chord along one of its edges (see Fig 4.1.2.4).
- (e) Web Joint: A joint formed by one or more webs along one edge of a given chord (see Fig 4.1.2.5).
- (f) Internal Joint: A joint formed by two web joints on opposite edges of a given chord such that their contact lengths overlap along the axis of the chord (see Fig 4.1.2.6).
- (g) Tail Bearing Joint: A joint consisting of a single member going to a support. (see Fig 4.1.2.7)
- (h) Top Chord Bearing Joint: A joint consisting of two or more members connecting at an exterior support. (see Fig 4.1.2.8)
- (i) Bearing Joint: A joint where a bearing touches a chord. (see Fig 4.1.2)

#### 4.1.2 Analogue Points

- (a) Simple Analogue Point: An analogue point consisting of only one point formed by two uniquely identifiable lines.
- (b) Compound Analogue Point: Analogue formed by two or more joints located at the same physical joint. (see Fig 4.1.2)

Except as in 4.1.3, analogue points shall be constructed as described in this section.

##### 4.1.2.1

Heel Analogue: The heel analogue is a compound analogue consisting of three simple analogue points and three fictitious members. (see Fig 4.1.2.1.A-G)

- a) First analogue point shall be determined as follows: Construct a vertical line at the end of TC or BC member whichever is shorter. (For Girder Heel, end of BC is always used to construct this line. See Fig 4.1.2.1.B. The only exception to this rule is in the case of a short cantilever. If the bearing occurs inside the point where the top chord terminates then this line is constructed at the end of the top chord and is considered the design span. See Appendix A.1 to A.4.) Find the intersection of the vertical line with the centrelines of the TC and BC. First heel analogue point shall be the lower of the two intersection points. This is the bearing point except as mentioned in (f) below.
- b) The second heel analogue point shall be located at the intersection of the centreline of BC and a vertical at 75% of scarf length from the first analogue point. This vertical may not be more than 610mm (24") away from the first analogue point.
- c) The third heel analogue point shall be located along the centreline of the top chord directly above the second heel analogue point.
- d) Where the second and the third points are closer to the first point than 2", remove the second and third points and reduce the heel analogue to simple analogue.
- e) In the case of a reinforcing wedge, the second heel analogue point shall be located at the intersection of the centreline of the BC and, a vertical at 75% of the combined BC and wedge scarf lengths, from the first analogue point. This vertical may not be more than 610mm (24") away from the first analogue point.
- f) In the case of a reinforcing member, a fourth point is required. The reinforcing member acts as the fourth member. The fourth point is the intersection of the

centreline of the chord with a line perpendicular to the chord at a distance "d/2" where "d" is the depth of the chord. (see Fig 4.1.2.1.C & D)

- g) In the case of a reinforcing web, the analogue is similar to the reinforcing member analogue with the following exceptions:
1. The fourth analogue point is the analogue point of the adjacent joint.
  2. The fourth member is the reinforcing web.
  3. The bearing point is the first analogue point only if all of the bearing surface falls between the first and second analogue points inclusive. (see Fig 4.1.2.1.C & E) Short cantilever and high heel rules apply. (see Appendix "A")
  4. If any part of the bearing surface falls past the second analogue point, the bearing point is at the second analogue point or a new bearing joint is introduced depending on the contact between the bearing surface and the scarf of the reinforcing web. (see Fig 4.1.2.1F) Short cantilever and high heel rules do not apply for this condition.
  5. If the reinforcing web is not fully parallel and touching the chord, two separate joints are constructed; a heel joint and a web joint. (see Fig 4.1.2.1G)

**4.1.2.2** Pitch Break Analogue Point: The pitch break analogue point shall be located along a plumb line through the outside edge intersection of the two chords. The analogue point shall have the same X coordinate as the plumb location and Y coordinate equal to the average Y coordinates formed by intersection points of the chord centrelines and the plumb line. (see Fig 4.1.2.2)

In case of a mitre cut pitch break, the analogue point is the intersection of the centrelines of the chords. (see Fig 4.1.2.2.A) For corner joints, the analogue point shall be the intersection of the centreline of the chord and a line at the end of the chord. (see Fig 4.1.2.2.B)

**4.1.2.3** Splice Joint Analogue Point: Analogue point shall be the point located at the halfway point between the intersection points of the centrelines of the two chord members and the splice line. (see Fig 4.1.2.3)

**4.1.2.4** Lapped Joint Analogue Point: Analogue point shall be the point located at the halfway point between the intersection points formed by the end cut and centrelines of the chord members on the two sides of the joint. (see Fig 4.1.2.4)

**4.1.2.5** Web Joint Analogue Point: Analogue point shall be the intersection of the centrelines of chord and a line perpendicular to the chord passing through the centre of contact area between the webs and the chord. (see Fig 4.1.2. and Fig 4.1.2.5)

**4.1.2.6** Internal Joint Analogue Point: Analogue point shall be the intersection of the centreline of chord and a perpendicular through the centre of common contact area, from both sides, between the webs and the chord. (see Fig 4.1.2.6)

**4.1.2.7** Tail Bearing Joint Analogue Point: Analogue point shall be at the intersection of the centreline of the chord and a vertical through outside corner of support. For a vertical tail bearing, use the horizontal through the outside corner of bearing instead of the vertical. (see Fig 4.1.2.7)

**4.1.2.8** Top Chord Bearing Joint: Except as in 4.1.2.9 the top chord bearing joint analogue is compound and consists of two points. The first point is the bearing point and it is the intersection of the centreline of the top chord with a vertical along the inside face of the bearing. The second point is the intersection of the centreline of the top chord with a vertical through the outside edge of any webs coming to the top chord at the bearing. The maximum distance allowed between these points is 13mm (1/2"). (see Fig 4.1.2.8 and Appendix D)

**4.1.2.9** Top Chord Bearing Joint With End Vertical and Block: The analogue of this point is compound and consists of three points and two fictitious members. The first joint is the bearing point and it is the intersection of a vertical through centreline of the required bearing size and surface of bearing. The second point is the intersection of a horizontal through the first point and the outside edge of end vertical. The third point is intersection of the centreline of the top chord and the outside edge of end vertical. (see Fig 4.1.2.9)

Top chord bearing joint guidelines in section 4.6.6 must be observed when using the analogue described in the above sections (4.1.2.8 and 4.1.2.9)

**4.1.3 Analogue Modifications**

**4.1.3.1** Analogue points shall be constructed using the following hierarchy: Pitch break joints, then, most member to least member web joints. All other joints not mentioned here may be constructed in any order.

**4.1.3.2** Analogue points for joints connected by a vertical web to joints of higher hierarchy shall be obtained as intersection of vertical through the higher hierarchy joint and the centreline of chord.

**4.1.3.3** Two analogue points closer to each other than 2" (unprojected) shall be reduced to one joint located between the two original joints.

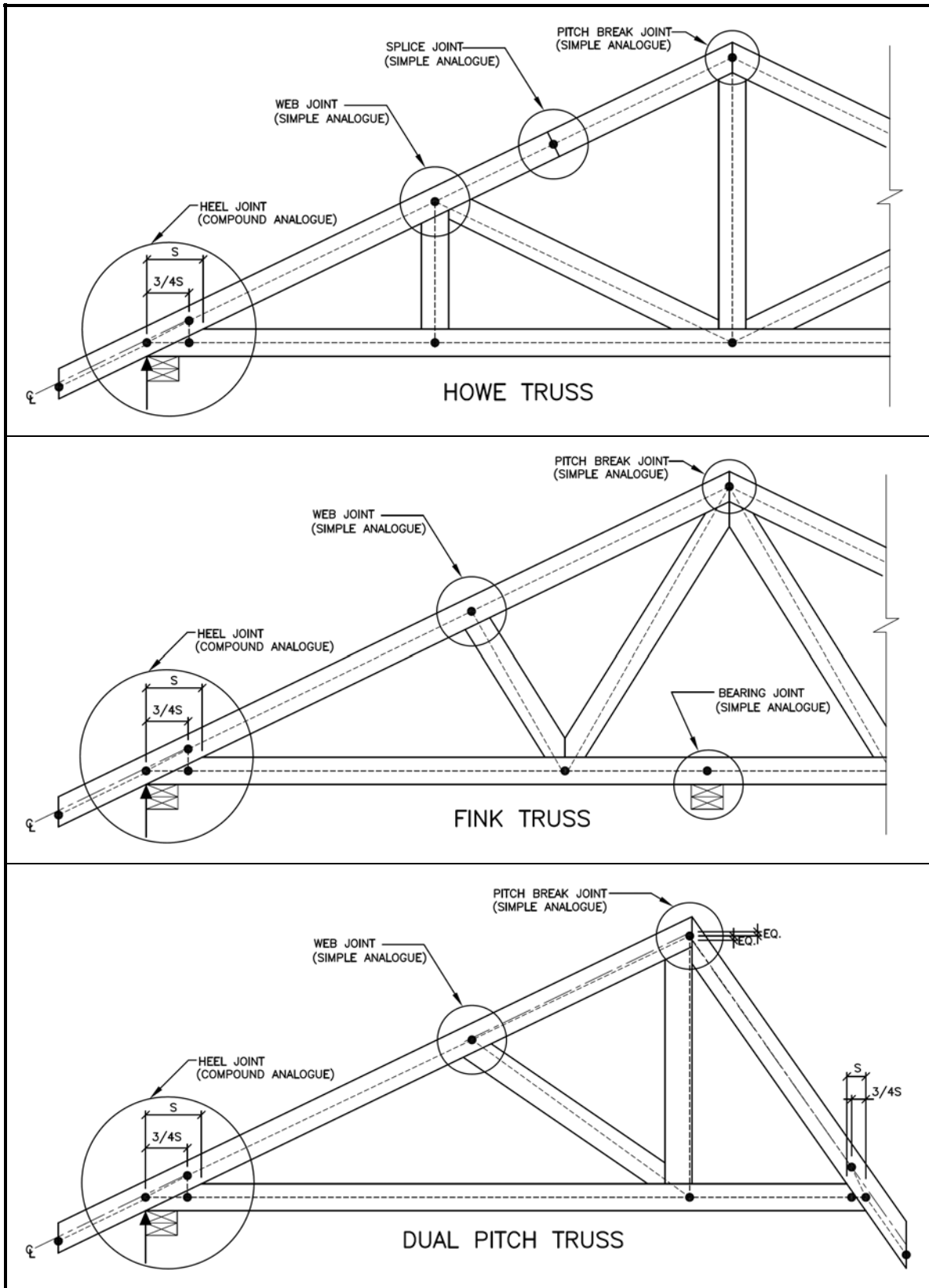

Figure 4.1.2 Simple and Compound Analogue

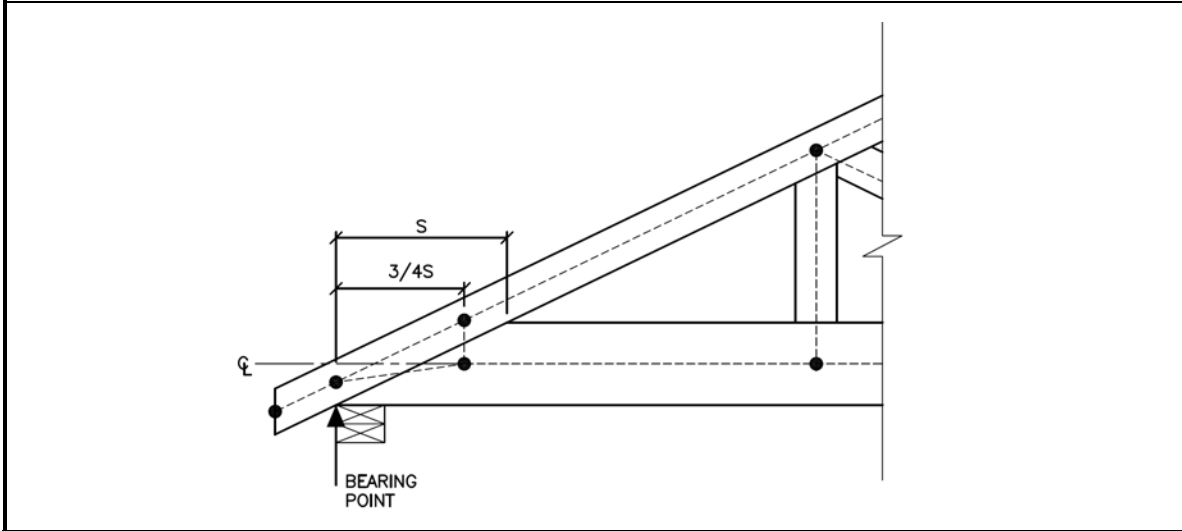
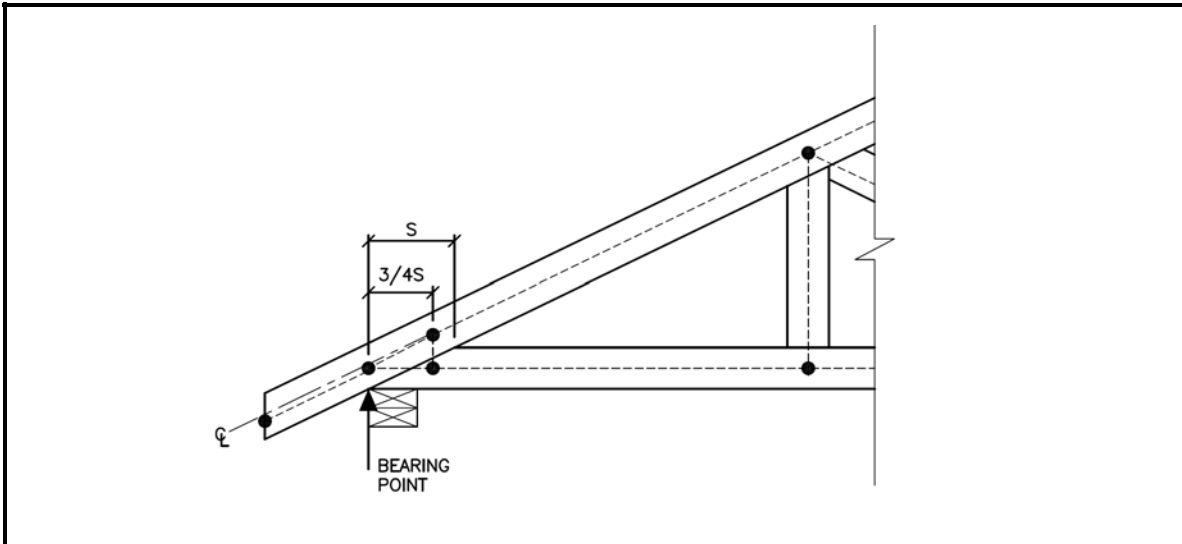

Figure 4.1.2.1.A Standard Heel Analogue

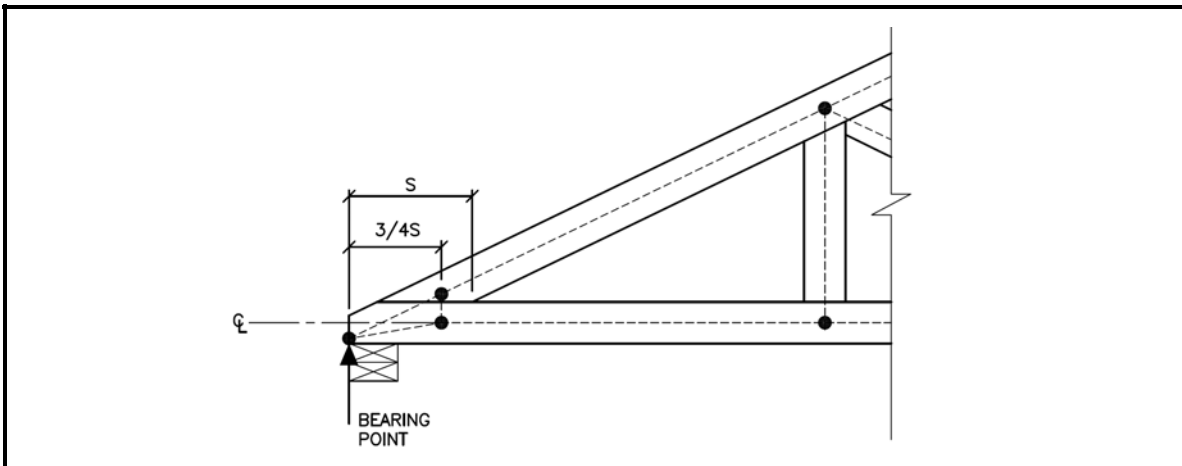

Figure 4.1.2.1.B Girder Heel

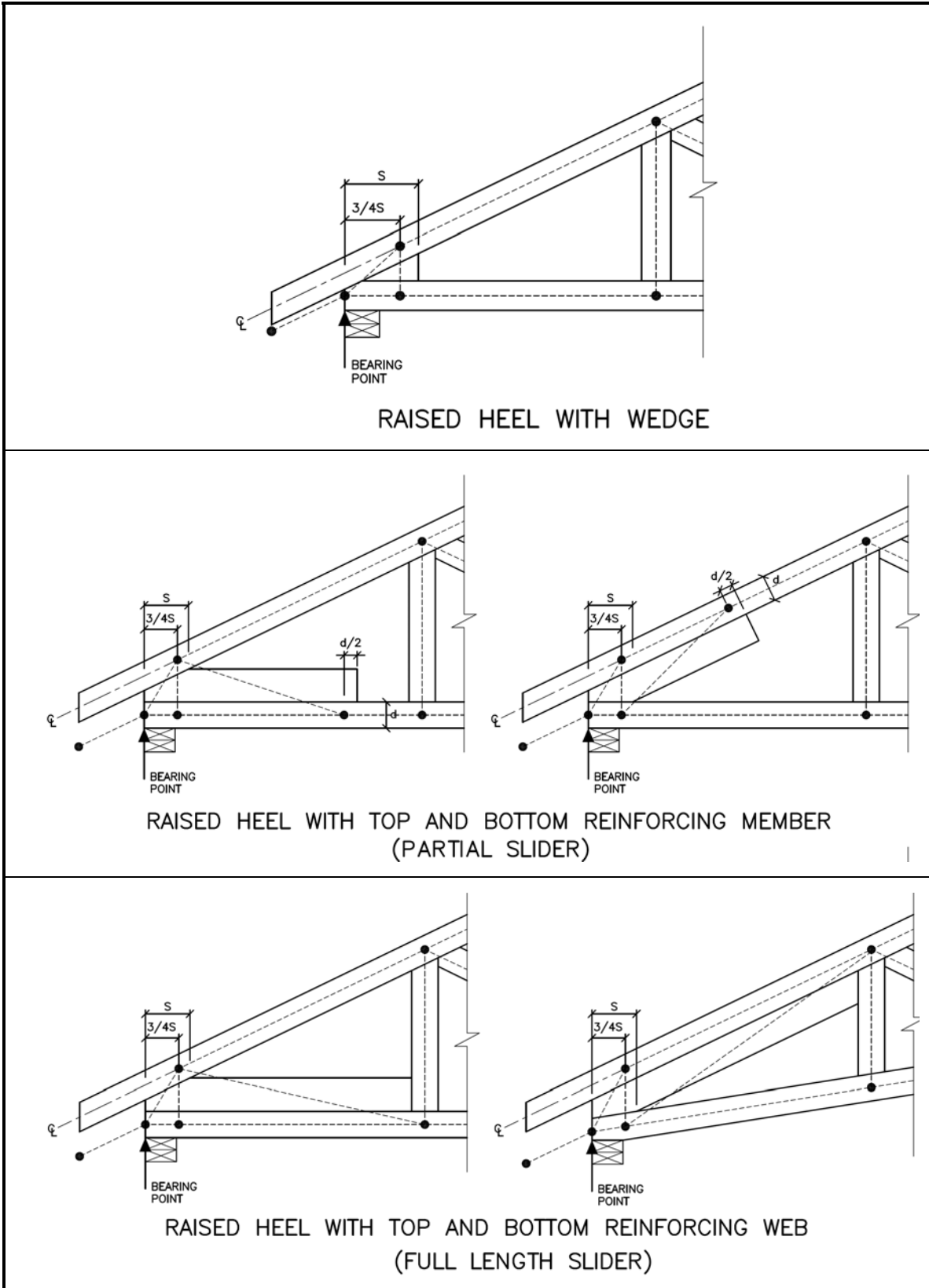

Figure 4.1.2.1.C Raised Heels

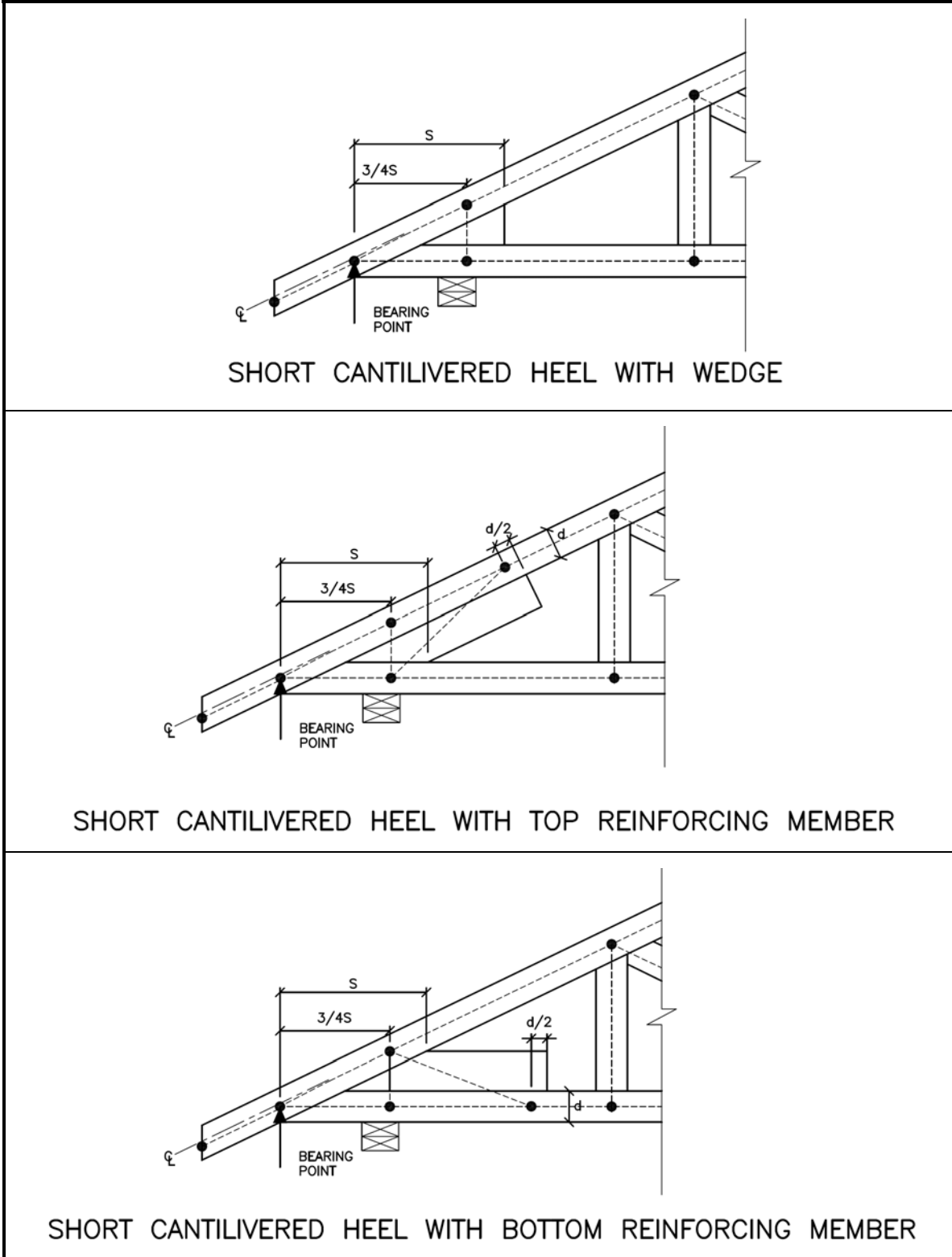

Figure 4.1.2.1.D Short Cantilevered Heels

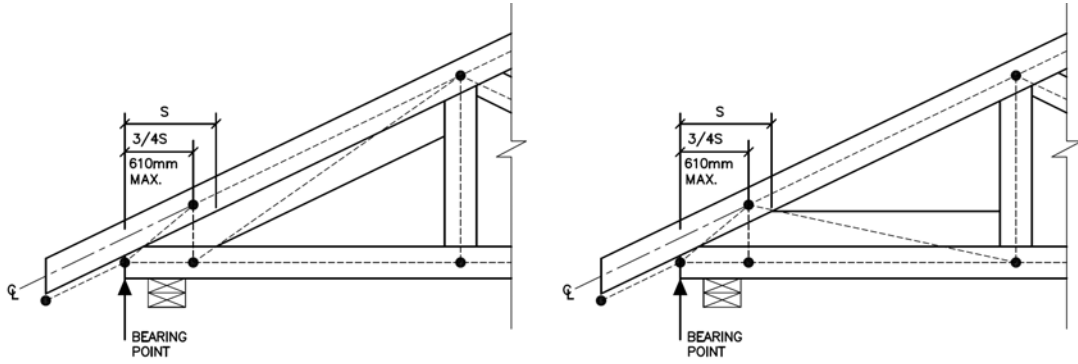

FIG. 4.1.2.1.E SHORT CANTILEVERED HEEL WITH TOP AND BOTTOM REINFORCING WEB. BEARING POINT AT FIRST ANALOGUE POINT.

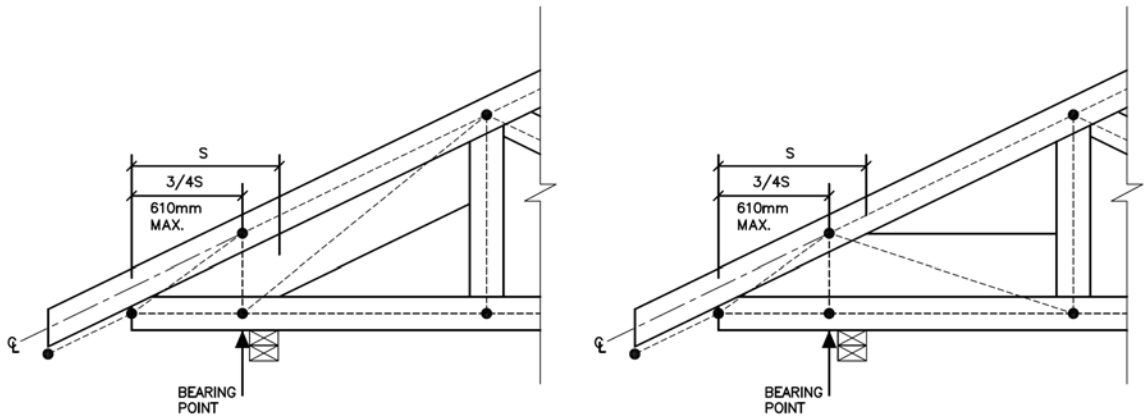

FIG. 4.1.2.1.F CANTILEVERED HEEL WITH TOP AND BOTTOM REINFORCING WEB. BEARING POINT AT SECOND ANALOGUE POINT.

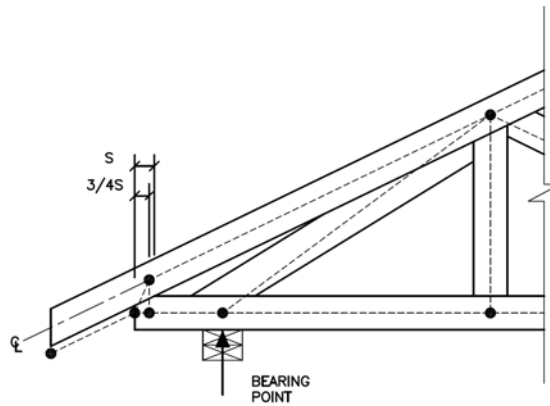

FIG. 4.1.2.1.G CANTILEVERED HEEL WITH TWO SEPARATE JOINTS.

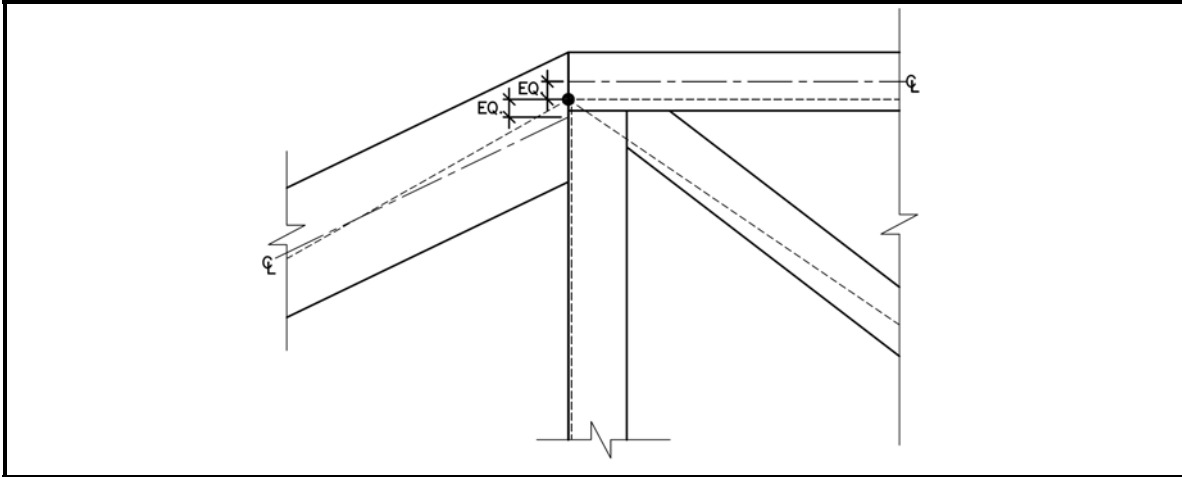

Figure 4.1.2.2 Pitch Break Joint

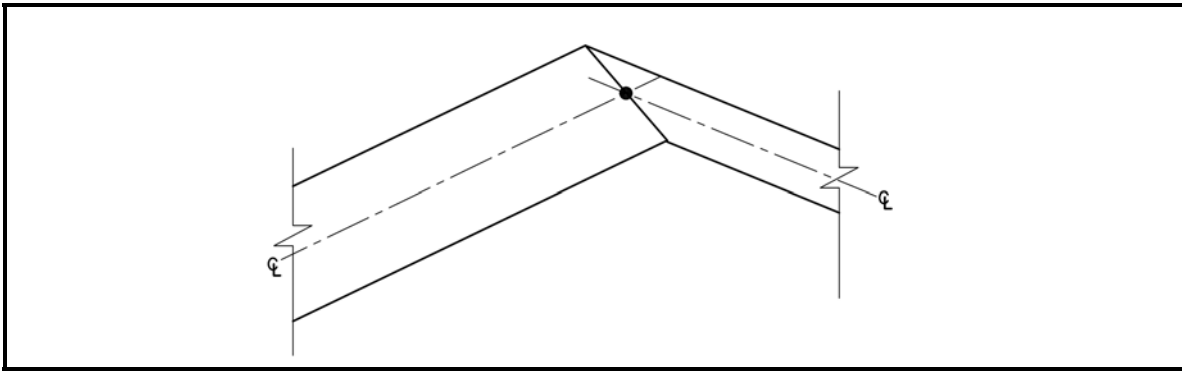

Figure 4.1.2.2.A Mitre Cut Pitch Break Joint

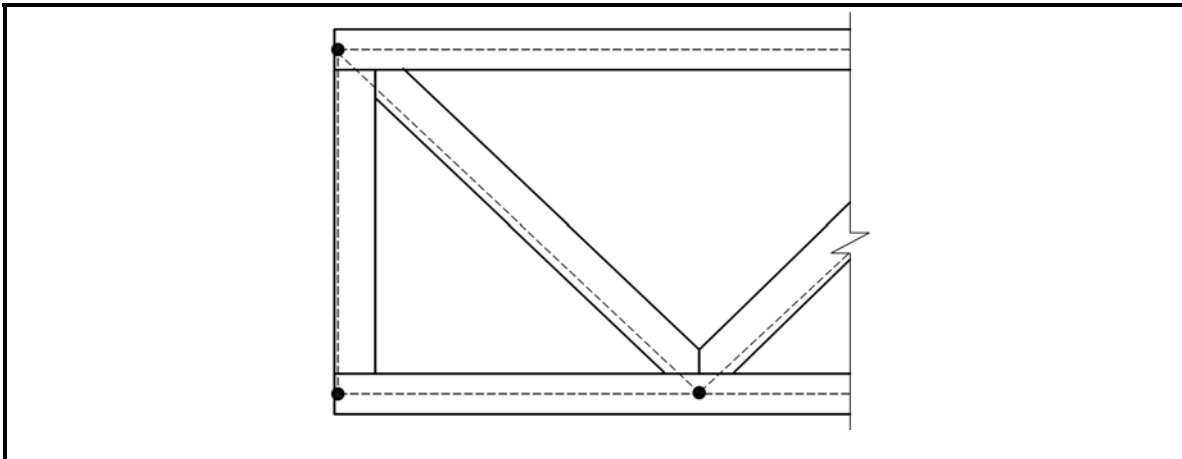

Figure 4.1.2.2.B Corner Joint

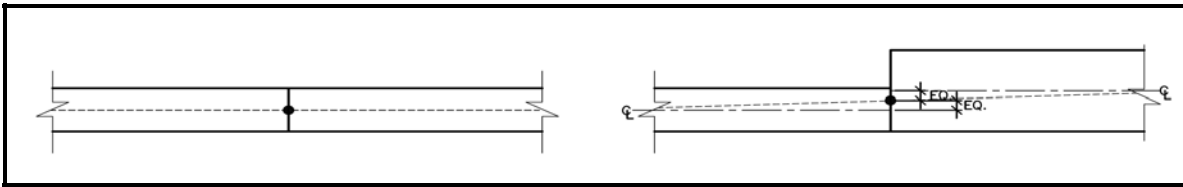

Figure 4.1.2.3 Splice Joint

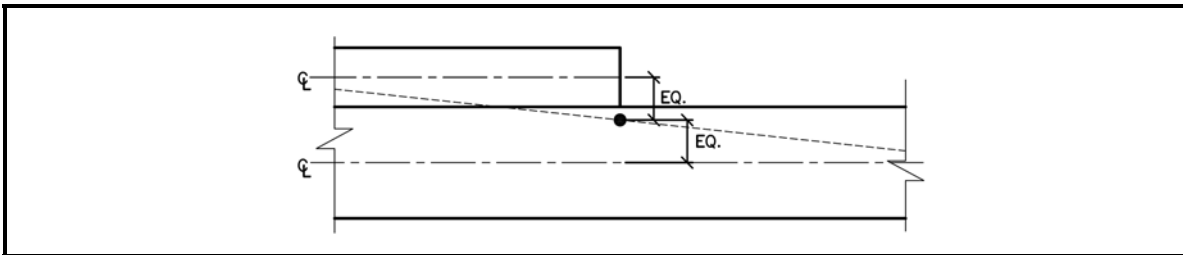

Figure 4.1.2.4 Lapped Joint

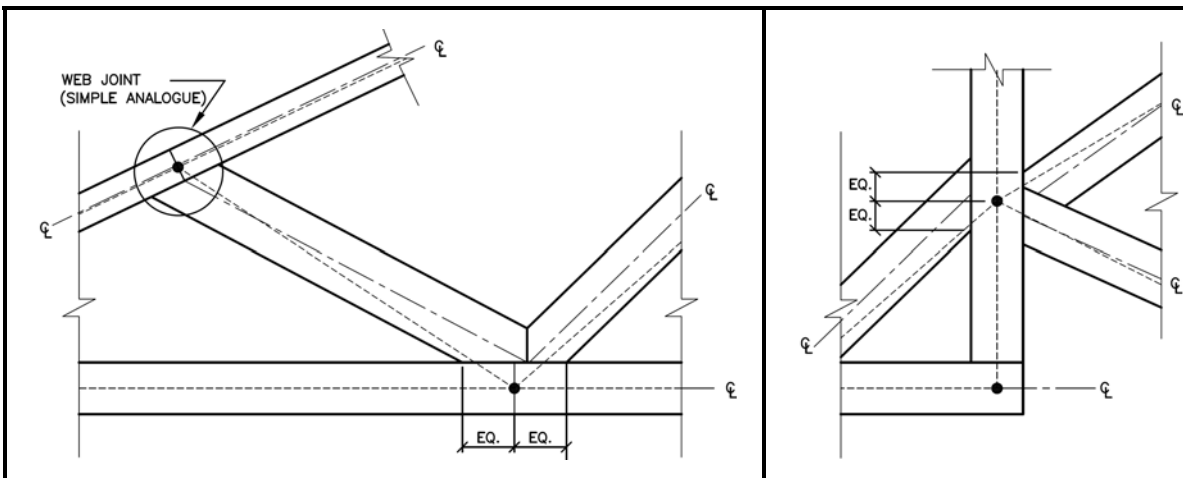

Figure 4.1.2.5 Web Joints

Figure 4.1.2.6 Internal Joint

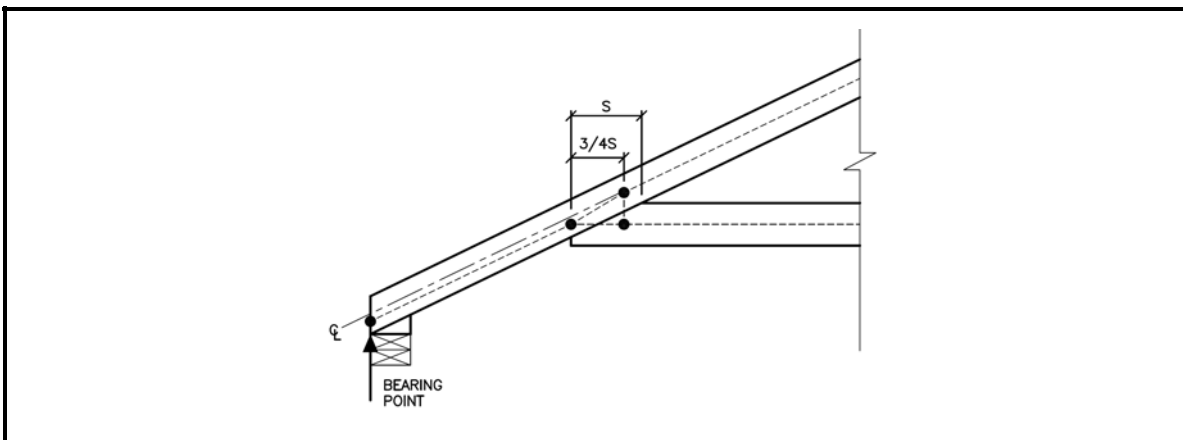

Figure 4.1.2.7 Tail Bearing Joint

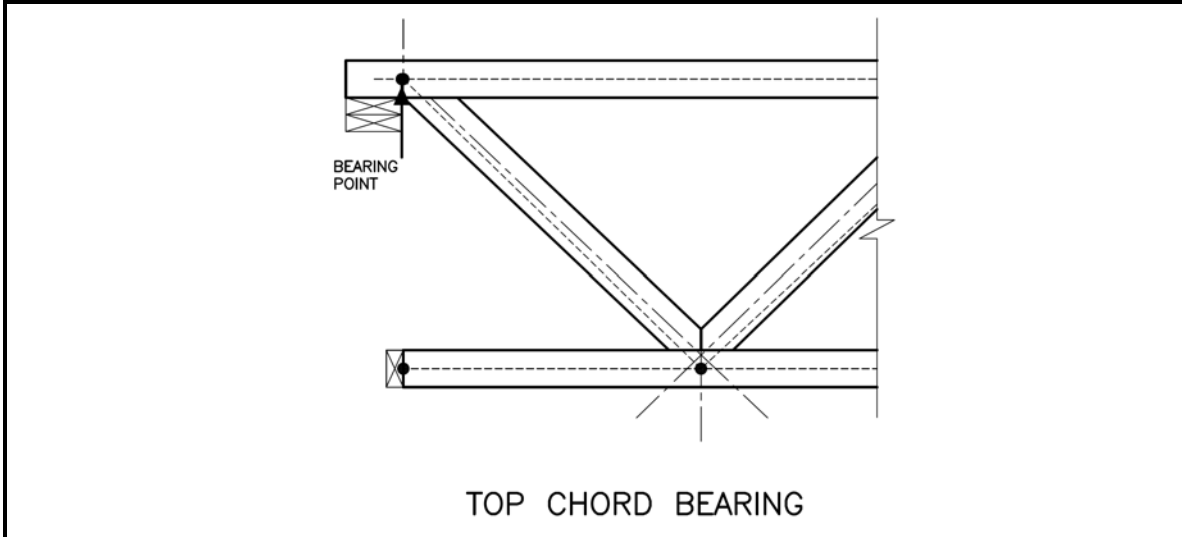
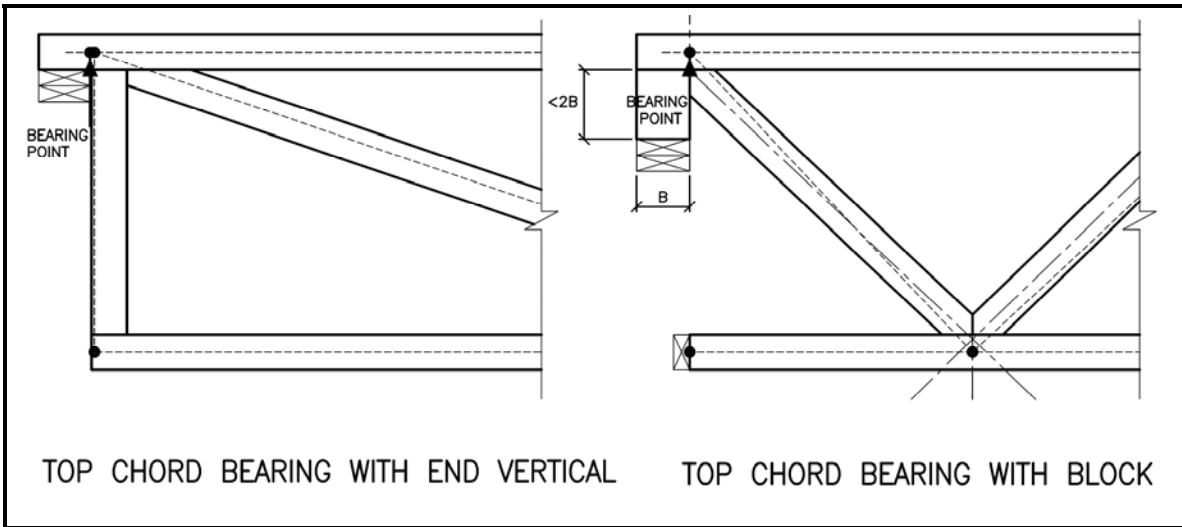

Figure 4.1.2.8 Top Chord Bearing Details

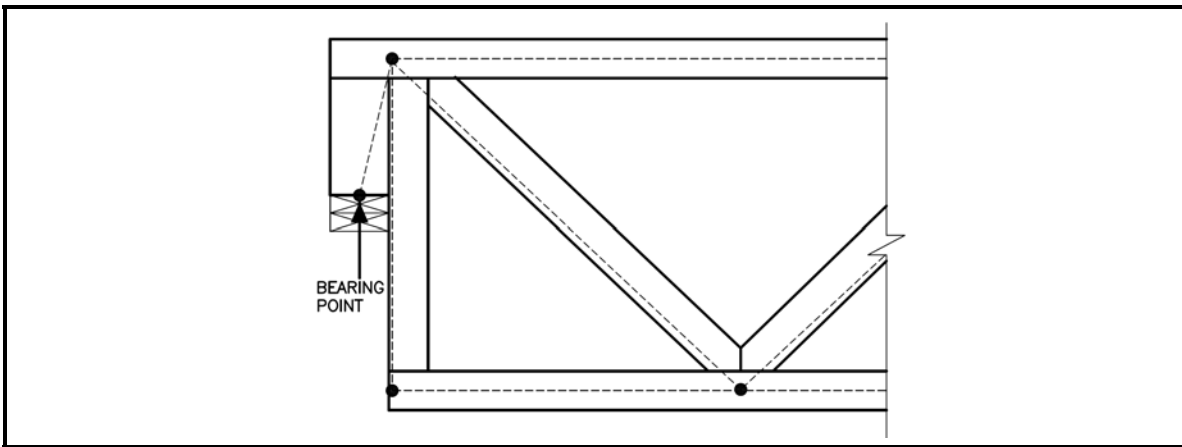

Figure 4.1.2.9 Top Chord Bearing with End Vertical and Block

## 4.2 ULTIMATE LIMIT STATES

### 4.2.1 Method of Analysis

Structural analysis shall be by stiffness or flexibility method utilizing pin-rigid mathematical model.

#### 1) Truss Model

- (a) All chord members shall be rigidly connected through joints, including web joints and lapped joints. All splices shall be considered pinned unless designed for moment. Fictitious members representing top and bottom chords at the heel shall be pinned to each other but rigidly connected at other end.
- (b) Ends of members connecting to pitch break joints shall be considered pinned at the joints.
- (c) The fictitious vertical strut at heel shall be pinned to top and bottom chords.
- (d) Properties of fictitious members shall be as follows:  
A top chord fictitious member shall have the same properties as the adjacent top chord. A bottom chord fictitious member shall have the same properties as the adjacent bottom chord. Other fictitious members shall have the properties of 2x4 No.2 S.P.F. lumber.
- (e) Fictitious members in top chord bearing conditions such as in detail 4.1.2.9 shall be pinned at both ends and have properties of 2x4 No. 2 S.P.F. lumber.
- (f) Overhangs shall be modelled such that they impose zero moment to the adjacent top chord member.

#### 2) Support Model

Except for the leftmost support, all supports shall be considered as horizontal or vertical rollers. The leftmost support must be pinned. No support shall be considered to provide rotational restraint unless such restraint is adequately specified on the drawing. At a heel joint the support shall be located at the first analog point (the outermost joint). Except at heel joints, a support is considered to be at a joint when there is an overlap between contact surfaces of bearing and webs. A support is considered to be at the heel joint if the heel condition is to be used with short cantilever rules. See Section 4.6.3

#### 3) Member Forces and Moments

- (a) Member force shall be the average of the member end forces. Member force for connections shall be the actual member forces at the joint.
- (b) Panel moment shall be taken as the maximum moment within the panel. Panel point moment shall be that at each individual panel end.
- (c) Combined Stress index shall be calculated for the panel on the basis of CSI from average member force combined with the greater of maximum panel moment or the maximum panel point moment.

### 4.2.2 Ultimate Limit States Requirements

The design of truss members for ultimate limit states shall include:

- (a) Establishing the value of the effect of the factored loads individually and with the load combinations specified in Section 3; and
- (b) Confirmation by rational means that for each load effect in item (a), the factored load effect does not exceed the factored resistance as determined by appropriate clauses of this standard.

### 4.3 SPECIFIED STRENGTHS

#### 4.3.1 Visually Stress-Graded Lumber

The specified strengths (MPa) for visually stress-graded structural joist and planks, light framing, structural light framing and stud grade categories of lumber shall be those presented in Table 5.3.1.A and Table 5.3.1.B of O86-09.

#### 4.3.2 Machine Stress-Rated And Machine Evaluated Lumber

The specified strengths (MPa) for machine stress-rated lumber are given in Table 5.3.2 of O86-09. The specified strengths (MPa) for machine evaluated lumber are given in Table 5.3.3 of O86-09. The specified strengths in shear are not grade dependent and shall be taken from Table 5.3.1.A of O86-09 for the appropriate species.

#### 4.3.3 Design Specified Strengths

The design specified strengths are the product of the basic specified strengths and the appropriate strength modification factors as in Section 4.3.4.

#### 4.3.4 Modification Factors

The strength modification factors are defined as follows:

- 1) Load Duration Factor,  $K_D$

The specified strengths and resistances shall be multiplied by a load duration factor,  $K_D$ , in accordance with table 4.3.4.(1)

**Table 4.3.4.(1) Load Duration Factor,  $K_D$**

Duration of Load	$K_D$	Explanatory Notes
Short term	1.15	Short term loading means that condition of loading where the duration of the specified loads is not expected to last more than 7 days continuously or cumulatively throughout the life of the structure. Examples include wind loads, earthquake loads, falsework, formwork, as well as impact loads.
Standard term	1.00	Standard term means that condition of loading where the duration of specified loads exceeds that of short term loading, but is less than long term loading. Examples include snow loads, live loads due to occupancy, wheel loads on bridges, and dead loads in combination with of all of the above.
Long term	0.65	Long-term duration means the condition of loading under which a member is subjected to more or less continuous specified load. Examples include dead loads or dead loads plus live loads of such character that they are imposed on the member for as long a period of time as the dead loads themselves. Such loads include those usually occurring in tanks or bins containing fluids or granular material, loads on retaining walls subjected to lateral pressure such as earth, and floor loads where the specified load can be expected to be continuously applied, such as those in buildings for storage of bulk materials. Loads due to fixed machinery should be considered to be long term.

Note: Load duration requires professional judgement by the designer.

1(a) Long term load factor

For Standard-term loads where the specified long-term load,  $P_L$ , is greater than the specified standard-term load  $P_S$ , the long-term load factor may be used or the factor may be calculated as follows:

$$K_D = 1.0 - 0.50 \log (P_L/P_S) \geq 0.65$$

where:  $P_L$  = specified long-term load  
 $P_S$  = specified standard term load based on S and L loads acting alone or in combination  
 = S; L; (S + 0.5L) ; OR (0.5S + L), determined using importance factors equal to 1.0

2) Service Condition Factor,  $K_S$

The specified strengths for sawn lumber shall be multiplied by the service condition factor  $K_S$  as indicated in Table 4.3.4.(2)

**Table 4.3.4.(2) Service Condition Factors,  $K_S$**

$K_S$	Property	Wet service	Dry Service
$K_{Sb}$	Bending at extreme fibre	0.84	1.0
$K_{Sv}$	Longitudinal shear	0.96	1.0
$K_{Sc}$	Compression parallel to grain	0.69	1.0
$K_{Scp}$	Compression perpendicular to grain	0.67	1.0
$K_{St}$	Tension parallel to grain	0.84	1.0
$K_{SE}$	Modulus of elasticity	0.94	1.0

3) Treatment Factor,  $K_T$

When lumber is treated with preservatives and retardants, the specified strengths, including modulus of elasticity, shall be decreased by treatment factor  $K_T$  as given in Table 4.3.4.(3)

**Table 4.3.4.(3) Treatment Factor  $K_T$**

Product	Dry service conditions	Wet service conditions
Untreated Lumber	1.00	1.00
Preservative Lumber <sup>(1)</sup>	1.00	1.00
Fire-retardant or other strength reducing chemically Treated Lumber	See note 2 for effects of fire retardant treatment	

Notes:

1. Refers to unincised lumber only. Incised treated lumber is not permitted in trusses.
2. For lumber treated with fire-retardant or other strength reducing chemicals, strength and stiffness capacities shall be based on the documented results of tests that shall take into account the effects of time, temperature, and moisture content. Test procedures shall meet the requirements of Clause 3.3.2. of O86-09.

4) System Factor,  $K_H$

Specified strengths for sawn lumber members in a light frame truss system consisting of three or more essentially parallel members spaced not more than 610 mm apart and so arranged that they mutually support the applied load may be multiplied by the system factor given in Table 4.3.4.(4)

**Table 4.3.4.(4) System Factor  $K_H$**

Symbol	Property	$K_H$
$K_{Hb}$	Bending	1.10
$K_{Hv}$	Longitudinal shear	1.10
$K_{Hc}$	Compression parallel to grain	1.10
$K_{Hcp}$	Compression perpendicular to grain	1.00
$K_{Ht}$	Tension parallel to grain	1.10
$K_{HE}$	Modulus of elasticity	1.00

Note: These system factor increases are also applicable when spacing does not exceed 1220 mm for low human occupancy applications and for all girders consisting of not less than 3 members.

5) Size Factor  $K_z$

Size factors presented in Table 4.3.4.(5) shall be used to increase basic specified strength.

**Table 4.3.4.(5) Size Factor,  $K_z$  For Visually Graded Lumber**

Symbol	Description	Lumber Size (mm) 38 x						
		64	89	114	140	184	235	286
$K_{zb}$	Bending	1.7	1.7	1.5	1.4	1.2	1.1	1.0
$K_{zv}$	Longitudinal shear	1.7	1.7	1.5	1.4	1.2	1.1	1.0
$K_{zc}$	Compression parallel to grain	*	*	*	*	*	*	*
$K_{zcp}$	Compression perpendicular to grain	**	**	**	**	**	**	**
$K_{zt}$	Tension parallel to grain	1.5	1.5	1.4	1.3	1.2	1.1	1.0
$K_{zE}$	Modulus of elasticity	1.0	1.0	1.0	1.0	1.0	1.0	1.0

\* See Section 4.4.3.(3)

\*\* See Section 4.4.4.(4)

6) Flat Roof Factor  $K_F$

Roof trusses meeting the housing and small building requirements of Part 9 of the NBCC10 and carrying flat roof (where roof portion with slope < 1:6 exceeds 50% of building width) shall be designed with a reduced factored resistance strength of lumber by applying a flat roof factor  $K_F = 0.75$ .

$K_F = 1.0$  for all other cases.

## 4.4 STRENGTH AND RESISTANCE

### 4.4.1 Bending Moment Resistance

- 1) The factored bending moment resistance,  $M_r$ , of sawn members shall be taken as:

$$M_r = \phi F_b S K_{Zb} K_L K_F$$

where  $\phi = 0.9$   
 $F_b = f_b (K_D K_{Hb} K_{Sb} K_T)$   
 $f_b =$  specified strength in bending, MPa  
 (Tables 5.3.1 to 5.3.3 of O86-09)  
 $S =$  section modulus,  $\text{mm}^3$   
 $K_{Zb} =$  size factor in bending  
 $K_L =$  lateral stability factor (Clause 4.4.1.(2))  
 $K_F =$  flat roof factor

- 2) Lateral Stability Factor,  $K_L$

The lateral factor  $K_L$  may be taken as unity when lateral support is provided at points of bearing to prevent lateral displacement and rotation, and the following additional support is provided:

**Table 4.4.1.(1) Lateral Stability Factor,  $K_L$**

MEMBER SIZE	SUPPORT CONDITION
38 x 64 (2x3) 38 x 89 (2x4) 38 x 114 (2x5) 38 x 140 (2x6)	No additional intermediate support is required.
38 x 184 (2x8)	The member is held in line by purlins.
38 x 235 (2x10)	The compressive edge is held in line by direct connection of sheathing or purlins spaced not more than 610 mm (24 in) apart.
38 x 286 (2x12)	The compressive edge is held in line by direct connection of sheathing or purlins spaced not more than 610 mm (24 in) apart and adequate bridging or blocking is installed at intervals not exceeding 2280 mm (90 in).

Note: Alternatively,  $K_L$  may be calculated in accordance with Clause 6.5.6.4 of O86-09.

### 4.4.2 Shear Resistance

The factored shear resistance,  $V_r$  for sawn members shall be taken as:

$$V_r = \phi F_v \frac{2A_n}{3} K_{Zv} K_F$$

where  $\phi = 0.9$   
 $F_v = f_v K_D K_{Hv} K_{Sv} K_T$   
 $f_v =$  specified strength in shear, MPa  
 (Tables 5.3.1A and 5.3.1B of O86-09)  
 $K_{Zv} =$  size factor in shear  
 $A_n =$  net area of cross-section,  $\text{mm}^2$   
 $K_F =$  flat roof factor

### 4.4.3 Compressive Resistance Parallel To Grain

#### 1) Effective Length

Unless noted otherwise, the effective length  $L_e = K_e L_p$  shall be used in determining the slenderness ratio of truss compression members.

where  $K_e = 0.8$  for buckling between adjacent panel points in the truss  
 $K_e = 1.0$  for buckling between brace or purlin locations on the truss  
 $L_p =$  actual length of member between adjacent analogue panel points, or; locations of braces or purlins restraining buckling (normally perpendicular to the plane of the truss). For design of truss webs the longest cutting length shall be used.

Other recommended effective length factors  $K_e$  for compression members can be found in Appendix A.5.5.6.1 of O86-09.

#### 2) Simple Compression Members - Constant Rectangular Cross-Section

The slenderness ratio  $C_c$  of simple compression members of constant rectangular section must not exceed 50 and shall be taken as the greater of:

$$C_c = \frac{\text{effective length associated with width}}{\text{member width}}$$

$$C_c = \frac{\text{effective length associated with depth}}{\text{member depth}}$$

Note: The slenderness ratio  $C_c$  of a simple tension member shall be limited to 80.  $K_e$  for a tension member should be taken as 0.8.

#### 3) Factored Compressive Resistance Parallel To Grain

The factored compressive resistance parallel to grain,  $P_r$  shall be taken as:

$$P_r = \phi F_c A K_{ZC} K_C K_F$$

where  $\phi = 0.8$   
 $F_c = f_c(K_D K_{Hc} K_{Sc} K_T)$   
 $f_c =$  specified strength in compression parallel to grain, MPa (Tables 5.3.1 to 5.3.3 of O86-09)  
 $K_{ZC} = 6.3(dL)^{-0.13} \leq 1.3$   
 $K_F =$  flat roof factor

where  $d =$  dimension in direction of buckling (depth or width), mm  
 $L =$  length associated with member dimension, mm

Note: The member length  $L$  used to compute the factor  $K_{ZC}$  shall be the greater of the panel length or one-half the chord length between pitch breaks for chord design; and, shall be the longest cutting length or the analogue length for web design.

#### 4) Slenderness Factor, $K_C$

The slenderness factor,  $K_C$ , shall be determined from:

$$K_C = \left\{ 1.0 + \frac{F_c K_{Zc} C_c^3}{35 E_{05} K_{SE} K_T} \right\}^{-1}$$

where  $E_{05} = 0.82E$  for MSR lumber  
 $= 0.75E$  for MEL lumber  
 $=$  as specified in Tables 5.3.1A and 5.3.1B of O86-09, for visually graded lumber

#### 4.4.4 Compressive Resistance Perpendicular To Grain (Bearing Resistance)

##### 1) Effect Of All Applied Loads

The factored compressive resistance perpendicular to grain under the effect of all factored loads shall be taken as  $Q_r$  in the following formula:

$$Q_r = \phi F_{cp} A_b K_B K_{Zcp} K_F K_p$$

where  $\phi = 0.8$   
 $F_{cp} = f_{cp}(K_D K_{Scp} K_T)$   
 $f_{cp}$  = specified strength in compression perpendicular to grain, MPa  
 (Tables 5.3.1 to 5.3.3 of O86-09)  
 $A_b$  = bearing area, mm<sup>2</sup>  
 $K_B$  = length of bearing factor, Clause 4.4.4.5  
 $K_{Zcp}$  = size factor for bearing, Clause 4.4.4.4  
 $K_F$  = flat roof factor  
 $K_p$  = bearing plate increase factor = 1.18 when truss plate, with minimum width of 3", is located over bearing such that the lower edge of the plate is flush with the lower edge of truss chord and the plate length covers the entire bearing length.

*Note: The requirements of 4.4.4.(1) may be met by providing adequate bearing reinforcement against the effects of concentrated bearing loads acting near a support. See Section 5.5.9*

##### 2) Effects Of Loads Applied Near A Support

The factored compressive resistance perpendicular to grain, under the effect of only those loads applied within a distance from the centre of the support equal to the depth of the member, shall be taken as  $Q'_r$  in the following formula:

$$Q'_r = (2/3) \phi F_{cp} A'_b K_B K_{Zcp} K_F K_p$$

where  $\phi = 0.8$   
 $F_{cp} = f_{cp}(K_D K_{Scp} K_T)$   
 $A'_b$  = average bearing area (Clause 4.4.4.(3))

##### 3) Unequal Bearing Areas On Opposite Surfaces Of A Member

Where unequal bearing areas are used on opposite surfaces of a member, the average bearing area shall not exceed the following:

$$A'_b = b \left\{ \frac{L_{b1} + L_{b2}}{2} \right\}, \text{ but } \leq 1.5b(L_{b1})$$

where  $L_{b1}$  = lesser bearing length, mm  
 $L_{b2}$  = larger bearing length, mm  
 $b$  = average bearing width (perpendicular to grain), mm

##### 4) Size Factor For Bearing, $K_{Zcp}$

For lumber used on flat, as opposed to on edge, the compression perpendicular to grain may be multiplied by a size factor for bearing,  $K_{Zcp}$  in accordance with Table 4.4.4.(4)

**Table 4.4.4.(4) Size Factor For Bearing,  $K_{ZCP}$** 

Ratio of Member Width To Member Depth*	$K_{ZCP}$
1.0 or Less	1.00
2.0 or More	1.15

\* Interpolation applies to intermediate ratios.

#### 5) Length Of Bearing Factor, $K_B$

When lengths of bearing are less than 150 mm, specified strengths in compression perpendicular to grain may be multiplied by a length of bearing factor in accordance with Table 4.4.4.(5) provided that:

- (a) no part of the bearing area is less than 75 mm from the end of the members; and
- (b) bearing areas do not occur in positions of high bending stresses.

**Table 4.4.4.(5) Length Of Bearing Factor,  $K_B$** 

Bearing Length Measured Parallel To Grain (mm)	Modification Factor, $K_B$
12.5 and Less	1.75
25.0	1.38
38.0	1.25
50.0	1.19
75.0	1.13
100.0	1.10
150.0 or More	1.00

#### 4.4.5 Tensile Resistance Parallel To Grain

The factored tensile resistance,  $T_r$ , parallel to grain shall be taken as:

$$T_r = \phi F_t A_n K_{Zt} K_F$$

where  $\phi = 0.9$   
 $F_t = f_t (K_D K_{Ht} K_{St} K_T)$   
 $f_t =$  specified strength parallel to grain, MPa  
 (Tables 5.3.1 to 5.3.3 of O86-09)  
 $A_n =$  net area of cross-section, mm<sup>2</sup>  
 $K_{Zt} =$  size factor in tension  
 $K_F =$  flat roof factor

#### 4.4.6 Stress Index due to Bending

Members subject to factored bending moment,  $M_f$ , shall be so proportioned that:

$$\frac{M_f}{M_r} \leq 1.0$$

#### 4.4.7 Stress Index due to Shear

Members subject to factored shear load,  $V_f$ , shall be so proportioned that:

$$\frac{V_f}{V_r} \leq 1.0$$

**4.4.8 Stress Index due to Compression (Parallel to Grain)**

Members subject to factored compressive axial load,  $P_f$ , shall be so proportioned that;

$$\frac{P_f}{P_r} \leq 1.0$$

**4.4.9 Stress Index due to Compression (Perpendicular to Grain)**

Members subject to factored compressive bearing load,  $Q_f$ , shall be so proportioned that;

$$\frac{Q_f}{Q_r} \leq 1.0$$

**4.4.10 Stress Index due to Tension**

Members subject to factored tensile axial load,  $T_f$ , shall be so proportioned that:

$$\frac{T_f}{T_r} \leq 1.0$$

**4.4.11 Combined Stress Index due to Tension and Bending**

Members subject to both bending and axial tension shall be so proportioned that:

$$\frac{T_f}{T_r} + \frac{M_f}{M_r} \leq 1.0$$

**4.4.12 Combined Stress Index due to Compression and Bending**

Except as permitted in Section 4.4.13, members subject to both bending and axial compression shall be so proportioned that;

$$\left(\frac{P_f}{P_r}\right)^2 + \frac{M_f}{M_r} \left(\frac{1}{1 - P_f/P_e}\right) \leq 1.0$$

where  $P_f$  = factored compressive force parallel to grain  
 $P_r$  = factored compressive resistance parallel to grain, clause 4.4.3  
 $M_f$  = factored bending moment  
 $M_r$  = factored bending moment resistance, clause 4.4.1  
 $P_E$  = Euler buckling load in the plane of the applied moment  
 $= \pi^2 E_{05} K_{SE} K_T I / L_e^2$

where  $E_{05}$  = modulus of elasticity for design compression members, MPa  
 $I$  = moment of inertia in the plane of the applied moment, mm<sup>4</sup>  
 $L_e$  =  $K_e L$

where  $K_e$  = effective length factor given in clause 4.4.3.(1)

**4.4.13 Combined Stress Index due to Compression and Bending**

(Modified formula as per Section 5.5.13.5 O86-09)

Provided;

- (a) the members form part of a fully triangulated, metal plate connected truss; and;
- (b) the spacing of the truss does not exceed 610 mm (24 in) or the truss does not support more than 610 mm (24 in) of uniform loading; and;
- (c) clear spans between bearings does not exceed 12.20 m (40 ft) and, the design span or overall length of the truss, not including overhangs, does not exceed 18.3 m (60 ft), and with no single cantilever length exceeding 25% of the adjacent clear span, and;

(d) the top chord slope is not less than 1/6, which is meant to exclude flat roof trusses but not flat top trusses forming part of hip roof systems;

Note: This clause is not for use with girder, bow string, semi-circular, attic, flat roof, or floor trusses.

Members subject to both bending and axial compression shall be so proportioned that;

$$\left(\frac{P_f}{P_r}\right)^2 + \frac{M_f}{K_M M_r} \leq 1.0$$

1) Bending Capacity Modification Factor,  $K_M$

The bending capacity modification factor,  $K_M$ , shall be determined as shown in the following:

(a) Compression chord members continuous over one or more panel points, and where;

$$1.0 < \frac{M_1}{M_2} \leq 3.0$$

$$K_M = \left[ 1.31 + 0.12 \left\{ \frac{M_1}{M_2} \right\} \right] \left\{ \frac{L_p}{d} \right\}^{-1/6} \leq 1.3$$

(b) Compression chord members continuous over one or more panel points, and where;

$$-1.0 \leq \frac{M_1}{M_2} \leq 1.0$$

$$K_M = \left[ 2.20 - 0.53 \left\{ \frac{M_1}{M_2} \right\} - 0.64 \left\{ \frac{M_1}{M_2} \right\}^2 + 0.41 \left\{ \frac{M_1}{M_2} \right\}^3 \right] \left\{ \frac{L_p}{d} \right\}^{-1/6} \leq 1.3$$

(c) All other compression chord members

$$K_M = 1.67 \left\{ \frac{L_p}{d} \right\}^{-1/6} \leq 1.3$$

where  $L_p$  = actual length of the member between adjacent analogue panel points, mm

$d$  = depth of the member between adjacent analogue panel points, mm

\* $M_1$  = maximum bending moment between analogue panel points, N-mm

$M_2$  = maximum of the two panel point bending moments, N-mm

Note: The sign of the bending moment,  $M_1$  and  $M_2$  are retained in determining  $K_M$ . The factored bending moment,  $M_f$ , used in Section 4.4.13 is the larger of the absolute value of  $M_1$  and  $M_2$ .

\* Maximum of bending moment at points along a panel where the slope of the moment curve changes sign. Where there are no such points along the panel,  $M_1$  shall take the value of the bending moment at mid panel.

#### 4.5 SERVICEABILITY LIMIT STATES

Design for serviceability Limit States shall include:

- (a) establishing the value of the effect of the specified loads individually and with the load combinations specified in Section 3; and
- (b) confirming by rational means that for each load effect in item (a), the structural effect falls within the limits specified in appropriate clauses contained herein.

##### 4.5.1 Serviceability Requirements (Allowable Deflections)

- 1) Modulus of Elasticity

The modulus of elasticity for stiffness calculations,  $E_S$ , shall be taken as:

$$E_S = E(K_{SE}K_T)$$

where

- $E$  = specified modulus of elasticity
- $K_{SE}$  = service condition factor
- $K_T$  = treatment factor

- 2) Joint and member deflections shall be determined using the methods presented in Section 4.2.1. Loadings used are as described in Section 3.0.
- 3) Maximum vertical truss deflection shall be the largest of deflections calculated at any panel point, or within any bottom chord panel. Top chord members shall be checked for their vertical panel deflections relative to their end points.
- 4) Maximum truss deflection and loadings to be considered in computing these deflections are as shown in Table 4.5.1.(4). Lengths to be used in the limit ratios are shown in Figure 4.5.1.(4)

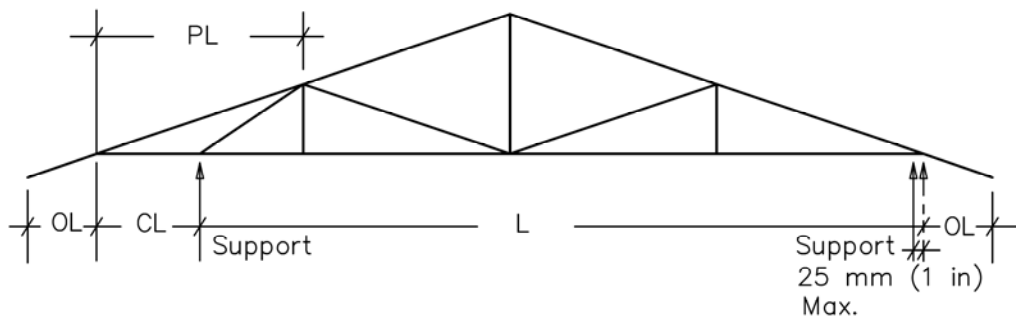

Figure 4.5.1.(4) Truss Deflection Lengths

**Table 4.5.1.(4) Truss Deflection Limitations**

Deflection Location	Application			
	Residential	Commercial	Farm	Floor
	Loading Used			
	1.33SL+0.5LL+DL	VL+DL	(SL+LL+WL)+DL	VL+DL
Allowable Deflection Limits - Vertical				
Top chord panel *	PL/180	PL/180	PL/180	PL/180
Bottom chord panel *	PL/240	PL/360	PL/240	PL/360
Cantilever	CL/120	CL/120	CL/120	CL/120
Overhang	OL/120	OL/120	OL/120	N/A
Bottom Chord Truss Joint or Panel	See Below	L/180 L/360 (DL)	L/180 L/360 (DL) See Note: 3 (LL)	L/180 L/360 (DL)
(a) Plaster/Gypsum ceiling	L/360	L/360 (VL)	L/360 (LL)	L/360 (VL)
(b) Other ceiling	L/240	L/240 (VL)	L/240 (LL)	L/360 (VL)
(c) No ceiling	L/180	L/240 (VL)	L/240 (LL)	L/360 (VL)
Allowable Deflection Limit - Horizontal				
At Roller Support	25 mm (1 in)	25 mm (1 in)	25 mm (1 in)	25 mm (1 in)

- Note: 1. SL refers to Snow Load contribution. LL refers to Occupancy Load contribution. WL refers to Wind Load contribution. DL refers to Dead Load contribution.
2. VL refers to variable load combinations of SL, LL and WL computed in accordance with table 3.1.3.2 Load Combinations for Serviceability Limit States.
3. (SL+LL+WL) were considered as Live Load (LL) in NBCC95. See TPIC 1996 for serviceability load combinations for Farm designs.
- \* Top and bottom chord panel deflection is local deflection measured relative to panel ends.

#### 4.5.2 Permanent Deformation

Structural members supporting continuously applied loads in excess of 50% of the total specified load shall be designed to avoid excessive permanent deformation. An upper limit of 1/360 of the span should be imposed on the deflection due to continuously applied loads.

#### 4.5.3 Ponding

The roof surface has to be provided with sufficient slope to allow drainage to prevent accumulation of rain water.

## 4.6 SPECIAL DESIGN CONSIDERATIONS

### 4.6.1 Overhangs

Top chord overhangs for all categories of trusses shall be treated as simple overhangs, with no consideration of any support provided by the soffit return, except in cases where the truss designer is able to ensure that such consideration is provided for in the design and construction of the building.

### 4.6.2 Splices

Splice locations as permitted in section 4.6.2.(1) and 4.6.2.(2) with tolerances described in 4.6.2.(3) are only intended for use in trusses where these locations are of low chord moment. i.e. Chords of triangulated, uniformly loaded, statically determinate trusses. For other cases where the splice is positioned at a location of substantial chord moment, it must either be designed for in the connection, or, eliminated by describing the splice as a pin joint in the analysis.

#### 1) Top Chord Splices

- (a) shall not be located at any joint and shall not be located in the panel adjacent to heel joint.
- (b) shall not be located at the quarter point adjacent to any perimeter break.
- (c) may be located at either quarter point of interior panels except there shall be no more than one splice per panel.

#### 2) Bottom Chord Splices

- (a) shall not be located in the panel adjacent to heel joint and shall not be located at the quarter point adjacent to any perimeter break.
- (b) may be located between quarter points of interior panels.
- (c) may be located at any interior joint except that the joint adjacent to heel joint may not be spliced. Kingpost and Queenpost trusses may be spliced at the bottom chord interior joint. See Figure 4.6.2.(2) for referenced truss configurations.

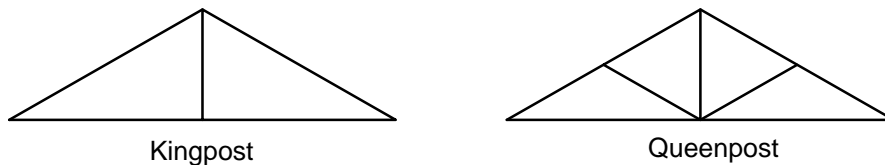

**Figure 4.6.2.(2) Kingpost and Queenpost Truss Configurations**

#### 3) Maximum Tolerance in Splice Location

Maximum tolerance in splice location shall be  $\pm 10\%$  of panel length.

#### 4.6.3 Short Cantilevers and Heel Cuts

Short cantilevers and high heel cuts shall be designed in accordance to procedures presented in Appendix A.

#### 4.6.4 Girder Trusses (Single and Multi-Ply)

- 1) Girder type heels are created by cutting the top chord onto a scarfed bottom chord. In this scarfing, the resulting section of bottom chord directly over the inside face of the bearing shall not be less than the greater of 50% of the original bottom chord section or 100 mm (4"). Girder type heel design procedures are presented in Appendix F.
- 2) Truss-to-truss connection of multi-ply girder trusses carrying load that is not evenly distributed to each ply shall be performed in accordance to Table B.1 to B.5, Appendix B. Girders carrying this type of loading shall be limited to 5 plies maximum.
- 3) Truss-to-truss connection of multi-ply girder trusses, carrying load that is evenly distributed to all plies, shall be performed using the minimum number of rows shown in Table B.1., Appendix B and a spacing of 305 mm (12 in). Girders carrying this type of loading shall be limited to 10 plies.

#### 4.6.5 Truss Bracing

- 1) For instructions on installation of temporary and permanent truss bracing, refer to BCSI brochure "Building Component Safety Information".  
Truss bracing location, as required in the design of the truss component, shall be specified by the truss designer/engineer.
- 2) For HSB trusses, minimum fastening of braces shall be as per NBCC10 Section 9.23.14.11

19 x 89 (1x4) braces	2 - 63 mm (2-1/2") common wire nails
38 x 89 (2x4) braces	2 - 76 mm (3") common wire nails.
- 3) An alternate method for bracing compression webs and long tension webs is by applying a member parallel to the web to form a T-section. See Table C.1.1, Appendix C.

#### 4.6.6 Top Chord Bearing Guidelines

- 1) For lumber-on-edge top chord bearing trusses the recommended maximum factored reactions for Spruce-Pine-Fir and D.Fir chords are as shown in Table D.1, Appendix D for the various truss configurations. The recommended maximum gaps and minimum chord coverage must be observed when using these values.  
Reaction limits are based on gross reaction and load duration factor for standard term loading. Values shall be adjusted downward for permanent loading and upward for short term loading using appropriate duration of load factors for plating.
- 2) For lumber-on-flat top chord bearing trusses, the recommended maximum factored reactions for Spruce-Pine-Fir and D.Fir chords are as shown in Table D.2 Appendix D for the various truss configurations. The recommended maximum gaps and minimum chord bites also shown must be observed when using these values.  
Reaction limits are based on gross reaction and load duration factor for standard term loading. Values shall be adjusted downward for permanent loading and upward for short term loading using appropriate duration of load factors for plating.

## 5. JOINT DESIGN PROCEDURES

### 5.1 GENERAL

The design requirements for truss plate joints, utilizing light gauge metal plates, shall be in accordance with O86-09 Section 10.

1) These procedures do not apply to the following conditions:

- (a) corrosive conditions
- (b) galvanized truss plates used in lumber that has been treated with fire retardant and is used in wet service conditions or in locations prone to condensation

*NOTE:*

*For metal connector plates used in environmental conditions that fall within the scope of (a) & (b) above, refer to Appendix E.*

2) Design criteria for truss plates are based on the following conditions:

- (a) the plate is prevented from deforming during installation;
- (b) the teeth are normal to the surface of the lumber;
- (c) the tooth penetration in joints is not less than that used in the tests to determine the resistance values; and
- (d) the lumber beneath the plate complies with Appendix G.

3) Thickness of members used in joints shall not be less than twice the tooth penetration.

4) Joint design shall be based on tight fitted joints with truss plates placed on opposing faces in such a way that, at each joint, the plates on opposing faces are identical and are placed directly opposite each other.

5) The lateral resistance value used to determine necessary plate area for any member shall be the appropriate value considering direction of load relative to grain and direction of load relative to primary axis of plate (see fig. 5.1.(5)). The resistance value is determined using the test values in conjunction with the formulae contained in Clause 5.3.3.

6) The unit values of lateral resistance of teeth shall be expressed as per tooth, per rosette, or per net area, whichever is appropriate or preferred. The design shall be based on net area method using test values or on gross area method using 80 percent of the test values and with areas defined in items (a) and (b) as follows:

- (a) the gross area is defined as the total area of member covered by a truss plate:
- (b) the net area is defined as the total area of a member covered by a truss plate less the area within a given distance from the edge or end of member. For net area calculation, the minimum end distance measured parallel to grain, shall be the greater of 12 mm (1/2"), or 1/2 the length of tooth; the minimum edge distance measured perpendicular to grain, shall be the greater of 6 mm (1/4"), or 1/4 the length of the tooth.

Any joint in a truss may be designed by either net or gross area method of joint design but not a combination of both within same joint.

7) Minimum Bite for Chords and Webs

At all joints, the connector plates are to be sized such that the minimum bites into all chords and webs are as given in Table 5.1.(7):

**Table 5.1.(7) Minimum Bite For Chords and Webs, mm (in)**

Lumber Size	Truss Length L, m ( ft )			
	$0 < L \leq 12.5$ ( $0 < L \leq 41$ )	$12.5 < L \leq 18.3$ ( $41 < L \leq 60$ )	$18.3 < L \leq 24.4$ ( $60 < L \leq 80$ )	$24.4 < L \leq 30.5$ ( $80 < L \leq 100$ )
38x64 (2x3)	38 (1.5)	45 (1.75)	51 (2.0)	57 (2.25)
38x89 (2x4)	38 (1.5)	45 (1.75)	51 (2.0)	57 (2.25)
38x114 (2x5)	38 (1.5)	45 (1.75)	51 (2.0)	57 (2.25)
38x140 (2x6)	38 (1.5)	51 (2.0)	57 (2.25)	64 (2.5)
38x184 (2x8)	51 (2.0)	57 (2.25)	64 (2.5)	76 (3.0)
38x235 (2x10)	64 (2.5)	70 (2.75)	76 (3.0)	83 (3.25)
38x286 (2x12)	76 (3.0)	76 (3.0)	83 (3.25)	89 (3.5)

- Note: (1) Plates must be sized so that the min. bite into chords is as shown above:  
 (a) parallel to chord direction  
 (b) perpendicular to chord direction  
 (2) Plates must be sized so that the min. bite into webs is as shown above:  
 (a) parallel to chord direction  
 (b) perpendicular to chord direction  
 (c) along the centreline of the web
- 3) An exception to the 38mm (1.5 in) minimum is the case of a single web to through-chord joint for  $0 < L < 12.5\text{m}$  ( $0 < L < 41\text{ft.}$ ) and for lumber sizes of 38x64 (2x3) to 38x140 (2x6) where 25 mm (1.0 in) wide, minimum 76 mm (3.0 in) long plates may be used.

## 5.2 CONNECTOR PLATE EVALUATION

- The metal connector plate design values (per tooth, nail, square mm, linear mm, or other unit) shall be determined in accordance to procedures contained in S347-99 "Method of Test for Evaluation of Truss Plates used in Lumber Joints" latest edition.
- The tensile and shear values, for connector plates manufactured from a grade of steel higher than that used in the plate testing program, may be adjusted by the ratio of the ultimate tensile strength of the steel used in the manufacturing of the plate to that of the steel used in the test plates. This adjustment does not apply to the gripping values; these values may require adjustment, so should be verified by test.
- Strength resistance values for plates and teeth are to be obtained from tests carried out in accordance with S347-99, where the resistance values are
  - the average, divided by 1.6, of the 3 lowest of 10 ultimate test values for lateral resistance of the teeth;
  - the average of the 2 lowest of 3 corrected test values for tensile strength of the plate; and
  - the average of the 2 lowest of 3 corrected test values for shear strength of the plate at the angles specified;

- 4) Lateral slip resistance values are to be obtained from tests carried out in accordance with S347-99, where the resistance values are the average of 10 test loads at 0.8 mm wood-to-wood slip divided by 1.4.

### 5.3 STRENGTH LIMIT STATES

#### 5.3.1 General

Truss plate joints shall be designed such that for the strength limit state, the effect of factored load is less than or equal to;

- (a) the factored ultimate lateral resistance of the teeth;
- (b) the factored tensile resistance of the plates; and
- (c) the factored shear resistance of the plates;

#### 5.3.2 Modification Factors

- 1) Load Duration Factor,  $K_D$   
The load duration factor  $K_D$  for truss plates is as previously given in Table 4.3.4.(1)
- 2) Service Condition Factor,  $K_{SF}$   
The service condition factor,  $K_{SF}$ , for truss plates is given in Table 5.3.2.(2)

**Table 5.3.2.(2) Service Condition Factor,  $K_{SF}$**

LUMBER CONDITION AT TIME OF MANUFACTURE			
Seasoned (Moisture Content 15%)		Unseasoned (Moisture Content > 15%)	
LUMBER CONDITION IN SERVICE			
DRY	WET	DRY	WET
1.00	0.67	0.80	0.67

- 3) Treatment Factor,  $K_T$   
For connections containing wood-based members treated with fire-retardant or other strength-reducing chemicals, strength capacities of connections shall be based on the documented results of tests that shall take into account the effect of time, temperature, and moisture content. Test procedures shall meet the requirements of Clause 3.3.2 from O86-09.  
**Note:** *The effects of fire-retardant treatments can vary depending on manufacturing materials and processes. See the Canadian Wood Council' Commentary for additional explanation.*
- 4) Flat Roof Factor,  $K_F$   
Roof trusses meeting the housing and small building requirements of Part 9 of the NBCC10 and carrying flat roof (where roof portion with slope < 1:6 exceeds 50% of building width) shall be designed with a reduced factored resistance strength of plate by applying a flat roof factor  $K_F = 0.75$ .

$K_F = 1.0$  for all other cases.

#### 5.3.3 Ultimate Lateral Resistance

The ultimate lateral resistance of the teeth,  $n_u$ , are calculated as follows:

- (a) For loads parallel to the primary axis of the plate

$$n_u = \frac{p_u q_u}{p_u \sin^2 \theta + q_u \cos^2 \theta}$$

and

(b) For loads perpendicular to the primary axis of the plate

$$n'_u = \frac{p'_u q'_u}{p'_u \sin^2 \theta + q'_u \cos^2 \theta}$$

where  $p_u$ ,  $q_u$ ,  $p'_u$ ,  $q'_u$  are the ultimate lateral resistances obtained in accordance with Clause 5.2.(3) (a) used with the following values of  $\theta$  and  $\rho$  :

$$p_u: \quad \theta = 0^0, \rho = 0^0$$

$$q_u: \quad \theta = 90^0, \rho = 0^0$$

$$p'_u: \quad \theta = 0^0, \rho = 90^0$$

$$q'_u: \quad \theta = 90^0, \rho = 90^0$$

where  $\theta$  and  $\rho$  are defined in Figure 5.1(5)

When the primary axis of the plate is oriented at an angle other than parallel or perpendicular to the direction of the load, the resistance value shall be determined by linear interpolation between the values  $n_u$  and  $n'_u$ .

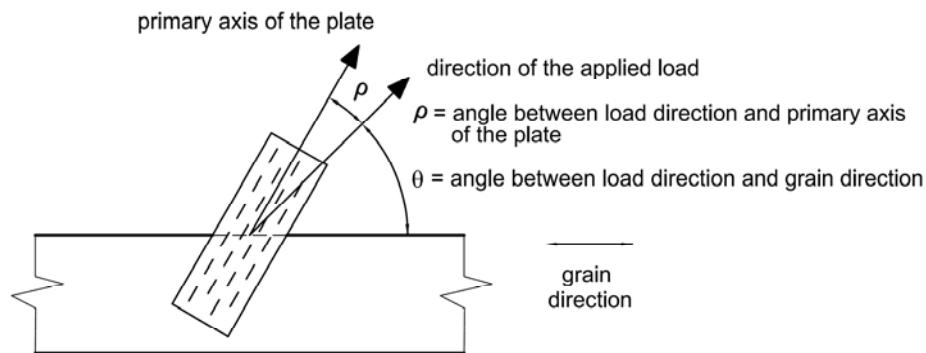

**Figure 5.1.(5)**  
**Truss Plate, Load and Grain Orientation**

### 5.3.4 Tensile Resistance

Tensile resistance of the plate,  $t_p$ , is determined for both parallel to and perpendicular to the direction of the plate primary axis in accordance with 5.2.(3) (b). For all other angles, tensile resistance shall be determined by linear interpolation.

### 5.3.5 Shear Resistance

Shear resistance of the plate,  $v_p$ , is determined for specified angles of plate primary axis to load direction in accordance with 5.2.(3) (c). For all other angles, shear resistance shall be determined by linear interpolation.

**5.3.6 Factored Resistance of Truss Plates**

For the strength limit state the factored resistances of truss plates shall be determined as follows:

- (a) The factored lateral resistance of the teeth,  $N_r$ , shall be expressed in terms of the surface area of the plates.

$$N_r = \phi N_u J_H K_F$$

where  $\phi = 0.9$   
 $N_u = n_u (K_D K_{SF} K_T)$   
 $J_H =$  moment factor for heel connection (Clause 5.5.7.(1) or (2))  
 $K_F =$  flat roof factor

- (b) The factored tensile resistance of the plates,  $T_r$ , shall be expressed in terms of the dimension of the plate measured perpendicular to the line of action of the applied forces.

$$T_r = \phi t_p K_F$$

where  $\phi = 0.6$   
 $t_p =$  tensile resistance of the plate (Clause 5.3.4)  
 $K_F =$  flat roof factor

- (c) The factored shear resistance of the plates,  $V_r$ , shall be expressed in terms of the dimension of the plate measured along the line of action of the shear forces.

$$V_r = \phi V_p K_F$$

where  $\phi = 0.6$   
 $V_p =$  shear resistance of the plate. (Clause 5.3.5)  
 $K_F =$  flat roof factor

**5.4 SERVICEABILITY LIMIT STATES**

Truss plate joints shall be designed such that for the serviceability limit state the effect of specified loads is less than or equal to the lateral slip resistance of the teeth.

- 1) Lateral Slip Resistance

The lateral slip resistance of the teeth,  $n_s$ , shall be calculated as follows:

- (a) For loads parallel to the primary axis of the plate

$$n_s = \frac{p_s q_s}{p_s \sin^2 \theta + q_s \cos^2 \theta}$$

and

- (b) For loads perpendicular to the primary axis of the plate

$$n'_s = \frac{p'_s q'_s}{p'_s \sin^2 \theta + q'_s \cos^2 \theta}$$

where  $p_s, q_s, p'_s, q'_s$  are the lateral slip resistances obtained in accordance with Clause 5.2.(4) used with the following values of  $\theta$  and  $\rho$ :

$p_s: \theta = 0^0, \rho = 0^0$   
 $q_s: \theta = 90^0, \rho = 0^0$

$$p'_s: \quad \theta = 0^0, \rho = 90^0$$

$$q'_s: \quad \theta = 90^0, \rho = 90^0$$

where  $\rho$  and  $\theta$  are defined in Figure 5.1.(5)

When the primary axis of the plate is oriented at an angle other than parallel or perpendicular to the direction of the load, the resistance value shall be determined by linear interpolation between the values  $n_s$  and  $n'_s$ .

- 2) For the serviceability limit state, the lateral slip resistance of the teeth,  $N_{rs}$ , shall be determined as follows:

$$N_{rs} = n_s K_{SF}$$

Where  $K_{SF}$  is the same as for strength limit state Table 5.3.2.(2)

## 5.5 MEMBER JOINT CONNECTIONS

### 5.5.1 Connection of Tension Members

- 1) The factored lateral resistance,  $N_r$ , in each tension member must be a minimum of 100% of the factored axial load in the member.
- 2) There must be sufficient factored tensile resistance,  $T_r$ , in the connector plates to transmit the full factored axial load in each tension member, considering the appropriate planes of action.

### 5.5.2 Connection of Compression Members

- 1) Metal connector plates resisting factored compressive axial loads shall be sized to provide factored lateral resistance,  $N_r$ , equal to the vectorial sum of no less than 50% of the component factored loads normal to the wood member interface, and 100% of the component factored loads parallel to the wood member interface.
- 2) Truss plates shall not be considered to transfer compression loads at joints.

### 5.5.3 Connection of Members for Shear

- 1) There must be sufficient factored lateral resistance of the teeth,  $N_r$ , in webs and chords to transmit the factored shear loads at a joint.
- 2) There must be sufficient factored shear resistance,  $V_r$ , in the truss plates to transmit the factored shear loads at a joint.

### 5.5.4 Combined Shear-Tension Resistance

The combined factored shear and tension resistance,  $C_{ST}$ , of the metal connector plate in the contact area of webs and chords, shall be determined as follows:

$$C_{ST} = (ST_{L1}L_1 + ST_{L2}L_2)$$

where;

$ST_{L1}$  - combined factored shear/tension resistance of the pair of metal connector plates through the line of contact L1. (see Figure 5.5.4)

$L_1$  - length of effective steel at the horizontal edge of the member under consideration.

$ST_{L2}$  - combined factored shear/tension resistance of the pair of metal connector plates through line of contact L2.

$L_2$  - length of effective steel at the vertical edge of the member under consideration.

$$ST_{L1} = V_{rL1} + \left(\frac{\theta_1}{90}\right)(T_{rL1} - V_{rL1})$$

$$ST_{L2} = T_{rL2} + \left(\frac{\theta_1}{90}\right)(V_{rL2} - T_{rL2})$$

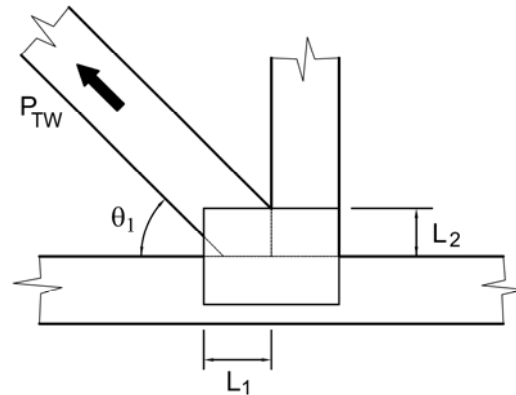

**Figure 5.5.4**  
**Shear-Tension Lengths and Angles**

$V_{rL1}$  - factored shear resistance parallel to the line of action, L1

$V_{rL2}$  - factored shear resistance parallel to the line of action, L2

$T_{rL1}$  - factored tensile resistance perpendicular to the line of action, L1

$T_{rL2}$  - factored tensile resistance perpendicular to the line of action, L2

$P_{TW}$  - factored tensile force in web

$C_{ST}$  ( $L_1$  and  $L_2$  shown in figure 5.5.4)  $\geq P_{TW}$

NOTE: Where the truss plate extends significantly past any chord and/or web member, additional blocking is recommended.

### 5.5.5 Net Section Lumber Check (h')

At all joints, members shall have metal connector plates sized and/or positioned so that the axial stress index of the member is not exceeded on the reduced net section resulting from the coverage of the plate (See Figure 5.5.5)

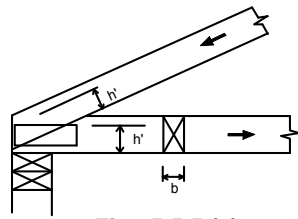

Fig. 5.5.5 (a)

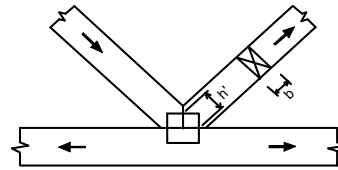

Fig. 5.5.5 (b)

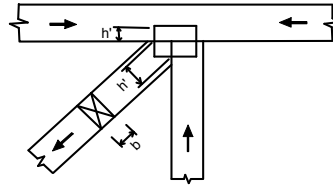

Fig. 5.5.5 (c)

**Figure 5.5.5**  
**Typical h' Dimensions**

**5.5.6 Tension Perpendicular-To-Grain Considerations**

Any joint which carries a factored concentrated load that is perpendicular to the chord or has a component that is perpendicular to the chord and/or has a shear component that is perpendicular to the chord and exceeds 2.5 kN (562 lbs) must be reinforced for tension perpendicular-to-grain with a minimum chord bite as follows:

$$\text{Min. Bite (mm)} = \frac{P - 2.500}{0.041} \text{ For Spruce-Pine-Fir}$$

$$\text{Min. Bite (mm)} = \frac{P - 2.500}{0.055} \text{ For Douglas-Fir-Larch}$$

where P = Factored Concentrated Load, kN

The calculated minimum bite requirement need not exceed 3/4 of the depth of the lumber.

**5.5.7 Heel Joint Considerations**

- 1) To allow for moment effects at the heel joint of pitched trusses, the heel joint moment factor  $J_H$  shall be as given in Table 5.5.7.(1)

**Table 5.5.7.(1) Heel Joint Moment Factors,  $J_H$**

Slope of top chord	$J_H$
Under 1/4 slope	0.85
1/4 to less than 1/3 slope	0.80
1/3 to less than 1/2.4 slope	0.75
1/2.4 to 1/2.2 inclusive	0.70
over 1/2.2 slope	0.65

- 2) In lieu of the values from the table above, the following formula can be used in determining the Heel Joint Moment Factor:

$$J_H = 0.85 - 0.05 (12 \tan\theta - 2.0)$$

where  $0.65 \leq J_H \leq 0.85$

$\theta$  = the angle between the top and bottom chord

- 3) Where the vertical reaction results in factored shear loads that exceed the factored shear resistance of the lumber, the heel joint lumber may be reinforced by additional plating. For the design of the additional plating for girder type heels, refer to Appendix F.
- 4) The heel joint of a chord extended rafter shall be plated as an ordinary heel joint with the appropriate heel joint moment factor applied. Consideration should be given to prevent splitting due to tension perpendicular-to-grain and longitudinal shear by supplementary plating on the continuous rafter.

### 5.5.8 Chord Member Splice Considerations

#### 5.5.8.1 General

For all chord splices the plate width shall be at least 65% of the width of the chord member.

#### 5.5.8.2 Tension Splices

- 1) When determining the factored tensile resistance of the metal connector plate, the maximum extension of the metal connector plate for an unblocked chord splice is 13 mm (1/2").
- 2) In the case of blocked tension splices, the total plate effectiveness shall be modified by the factor K as defined by the following equation:

$$K = 0.97e^{-0.001(3.937 + 0.0186(88.9-h))X}$$

where: h = Actual width of wood member, mm.

X = Extension of plate above member. Maximum X allowed in this calculation is 89 mm (3.5").

- Note:
- (1) For an un-blocked tension splice with an extension of 13mm (1/2") or less, K is equal to 1.00
  - (2) In the case of a splice occurring at the panel joint, webs framing into joint shall be considered as blocking.
  - (3) Maximum plate width to be applied with effectiveness factor K cannot be in excess of the member actual width h, plus the maximum extension, X.

#### 5.5.8.3 Compression Splices

- 1) Compression splice plates shall be designed so that the factored ultimate lateral resistance in each member will be at least equal to 65% of the factored compressive axial load.
- 2) In plumb cut compression joints the metal connector plates resisting factored compressive axial loads shall be sized to provide factored ultimate lateral resistance, equal to the vectorial sum of no less than 65% of the component factored loads normal to the wood member interface and 100% of the component factored loads parallel to the wood member interface.

### 5.5.8.4 Moment Considerations

When in line members terminate at a splice, where chord moment should be considered, the splice plates must have sufficient resistance to transfer this factored bending moment in addition to the factored axial load. This resistance is in both plate steel section clause 5.5.8.4.1 and plate tooth gipping clause 5.5.8.4.2. See also clause 4.6.2

#### 5.5.8.4.1 Design of Steel Section for Effect of Moment

The factored moment resistance in combination with tension  $M_{Tr}$ , of a pair of connector plates at a splice joint shall be taken as:

$$M_{Tr} = 0.27 t_p (0.5w_{br} + y)^2 + 0.18 b C(0.5d - y)^2 - \frac{T_f}{K_F} y$$

$$y = \frac{0.25bdC + 1.85 \frac{T_f}{K_F} - 0.5w_{br}t_p}{t_p + 0.5bC}$$

- where:  $t_p$  = corrected tensile resistance of the connector plates, N/mm  
 $w_{br}$  = effective plate width for steel section calculations, mm (clause 5.5.8.2)  
 $y$  = distance from the chord centreline to neutral axis of wood/steel combination, mm ( $y$  can be positive or negative but the moment formula is invalid if  $y$  lies outside the plate)  
 $b$  = chord thickness, mm  
 $C$  =  $F_c$ , MPa  
 $F_c$  =  $f_c(K_D K_{Sc} K_T K_{Zc})$   
 $d$  = chord depth, mm  
 $T_f$  = factored tension force in chord at the splice (set equal to zero for compression), N  
 $K_F$  = flat roof factor

The stress ratio for moment in combination with axial tension shall be taken as the following:

$$\frac{M_f / K_F}{M_{Tr}} \leq 1.0$$

where  $M_f$  = factored bending moment in the chord at the splice, N•mm

The stress ratio for the axial tension shall be taken as the following:

$$\frac{T_f}{T_r w_{br}} \leq 1.0$$

where  $T_r$  = factored tension-only resistance of the connector plate N/mm, (including  $K_F$ )

### 5.5.8.4.2 Design of Plate Lateral Resistance for Effect of Moment

The moment applied at the splice joint shall not exceed the moment capacity in lateral resistance in any orientation, nor the combined capacity for moment and non-moment loads defined as follows:

$$V_M \leq V_{LRmin}' \quad \text{and,}$$

$$V_M + V_p \leq V_{LR}'$$

$$V_M = 4M_f / (A_{ef} D)$$

$$D = \sqrt{(A_{ef}/h)^2 + h^2}$$

where:

- $V_M$  = tooth holding stress due to the factored moment on a pair of plates, Mpa
- $V_p$  = tooth holding stress resultant of factored shear and axial loads in wood on a pair of plates, Mpa, equal to the vector addition of the factored shear + axial loads in wood, divided by  $A_{ef}$
- $V_{LR}'$  = allowable tooth holding stress for a pair of plates for the orientation of  $V_p$  per section 5.5.3 with modification factors of 5.3.2, Mpa (including  $K_F$ )
- $V_{LRmin}'$  = minimum allowable tooth holding value for any angle of load at the joint for a pair of plates determined from section 5.5.3 with modification factors of 5.3.2, Mpa (including  $K_F$ )
- $A_{ef}$  = effective plate area on one face of each wood member at the splice joint,  $mm^2$
- $D$  = diagonal of rectangle equivalent to  $A_{ef}$ , mm
- $h$  = height of equivalent rectangle, equal to the greatest dimension across  $A_{ef}$ , perpendicular to the longest side of  $A_{ef}$ , mm

### 5.5.9 Compression Perpendicular-To-Grain

Any joint which carries a factored concentrated compressive load that subjects the member to compression perpendicular to grain stresses through the depth of the member (example: the bottom chord on a bottom chord bearing flat truss) such that a reduction of bearing strength as described in section 4.4.4.(2) applies, may be reinforced with connector plates so that the increased bearing strength of section 4.4.4.(1) may be used. This bearing reinforcement consists of applying connector plates at the joint of a size that permit coverage of the chord member to within 6 mm ( $\frac{1}{4}$ " ) of the edge making contact with the bearing. When using this reinforcement to reduce bearing size, the web member contact on the opposite surface to the bearing, must be at least equal to that of the bearing. See figure 5.5.9.

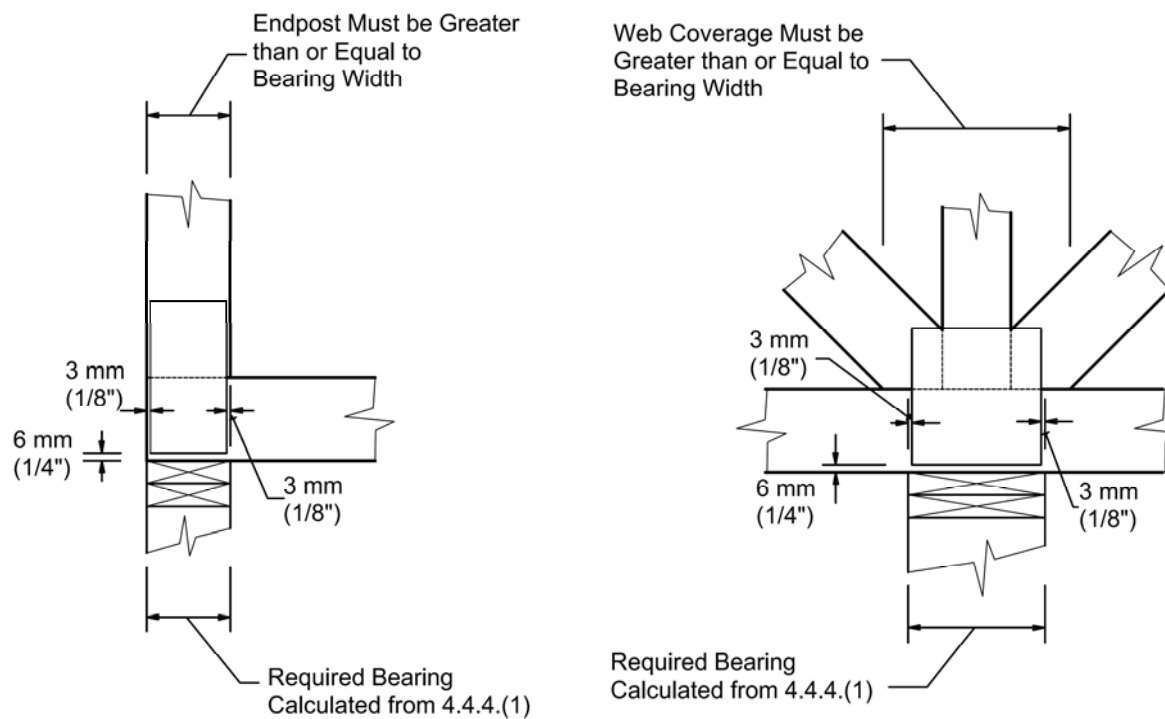

**FIGURE 5.5.9 Bearing Reinforcement With Connector Plates**

**6. MANUFACTURING AND MATERIAL VARIANCES**

Minimum quality manufacturing criteria including tolerances to allow for manufacturing variances can be found in Appendix G.

**7. TRUSS DESIGN DRAWING**

In addition to the truss drawing itself, minimum design information to be included on the truss design drawing can be found in Appendix H.

**A.1 SHORT CANTILEVERS: DETAIL WITHOUT REINFORCING**

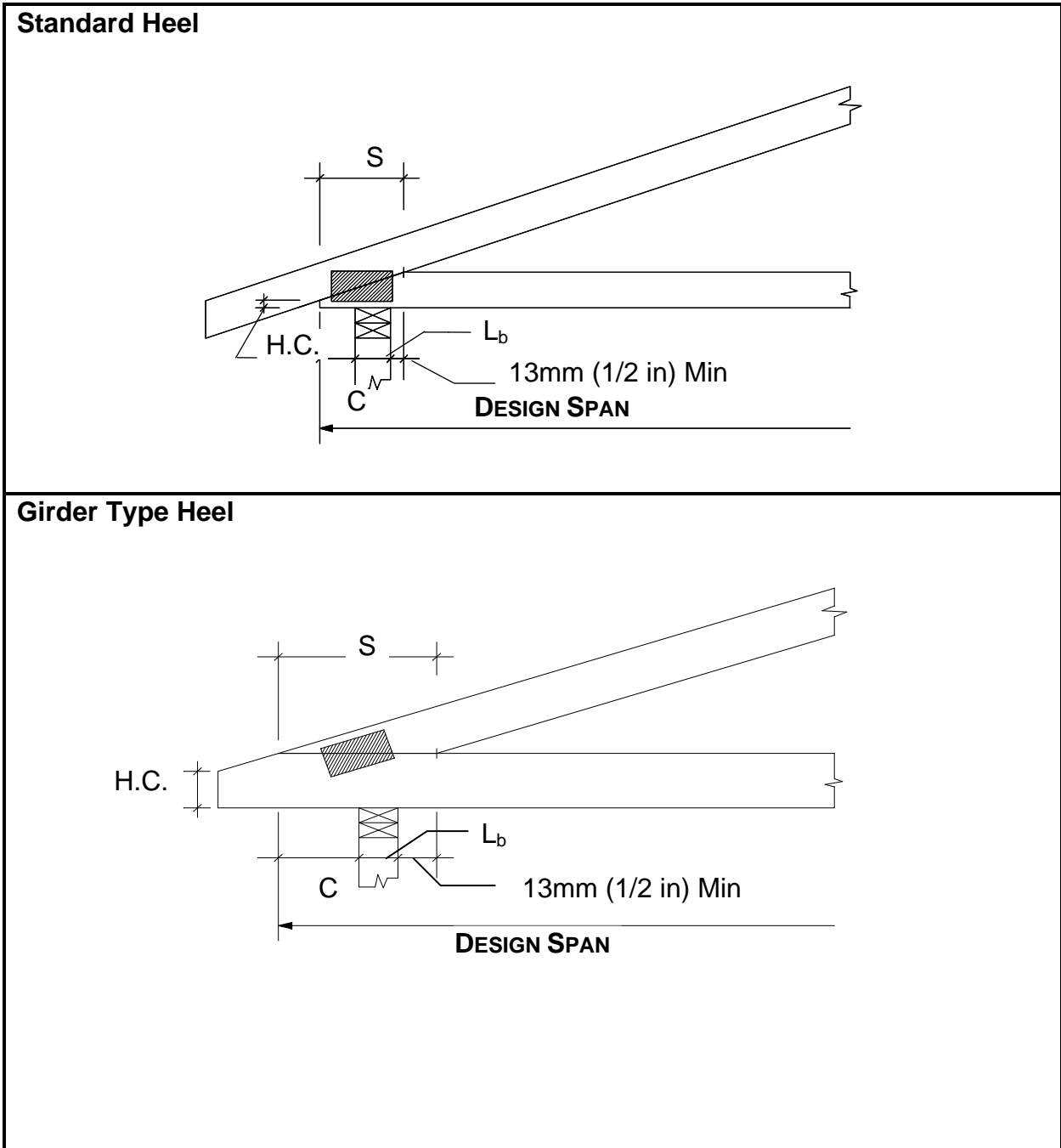

**MAXIMUM CANTILEVER "C" CALCULATION**

$$C(\text{mm}) = S(\text{mm}) - (L_b(\text{mm}) + 13 \text{ mm})$$

$$C(\text{in}) = S(\text{in}) - (L_b(\text{in}) + 1/2 \text{ in})$$

**A.2 SHORT CANTILEVERS: DETAIL WITH WEDGE REINFORCING**

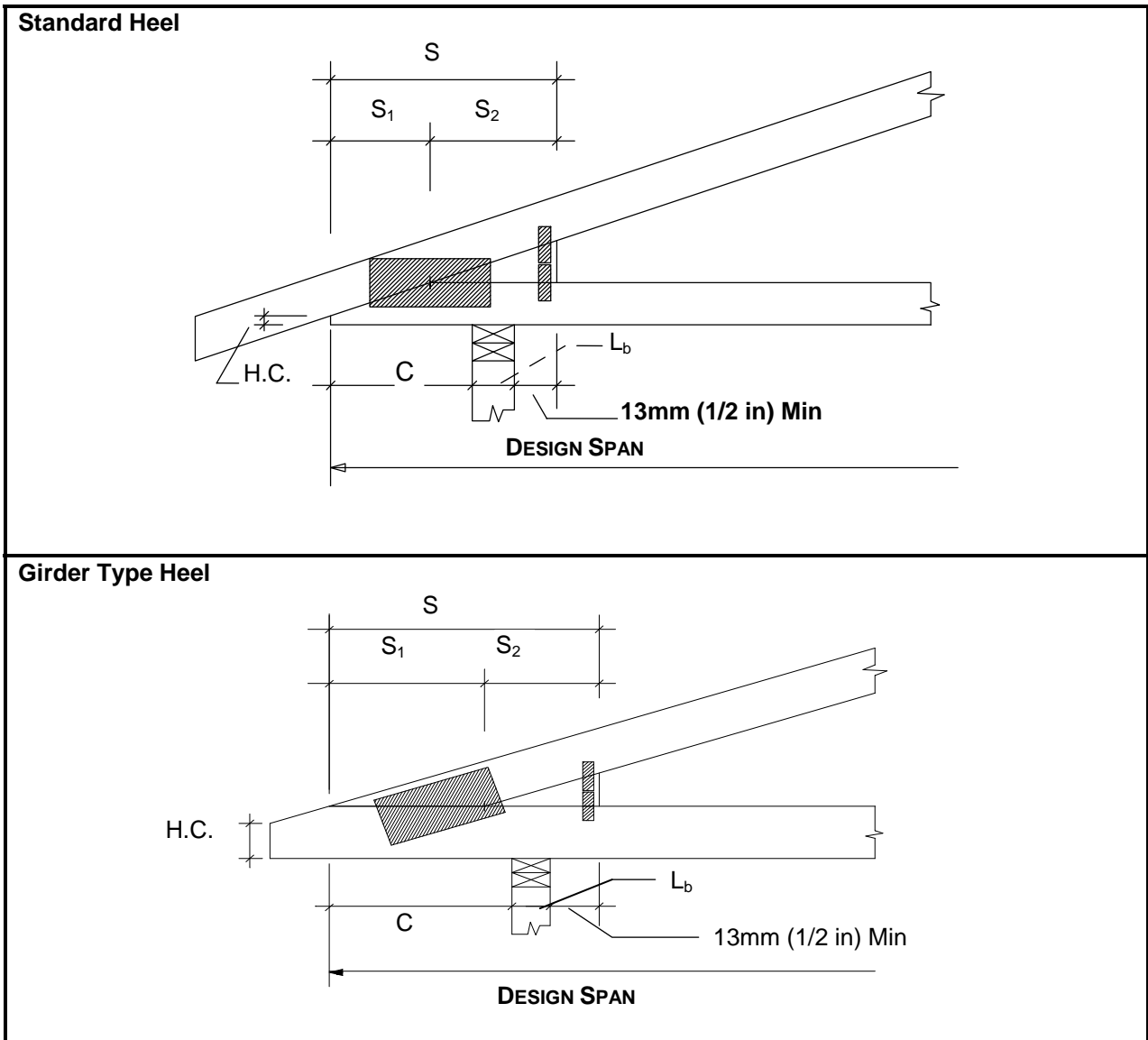

**MAXIMUM CANTILEVER "C" CALCULATION**

$$C(\text{mm}) = S_1(\text{mm}) + 89 \text{ mm}$$

$$C(\text{in}) = S_1(\text{in}) + 3 \frac{1}{2} \text{ in}$$

- Notes:
1. Minimum value for  $S_2(\text{mm}) = L_b(\text{mm}) + 102\text{mm}$   
 $S_2(\text{in}) = L_b(\text{in}) + 4 \text{ in}$
  2. Maximum value for  $S_2$  in determining analogue distance  $S$  is that calculated for a wedge depth equaling the bottom chord depth.

**A.3 SHORT CANTILEVERS: DETAIL WITH PARTIAL TOP CHORD REINFORCING MEMBER (PARTIAL TOP CHORD SLIDER)**

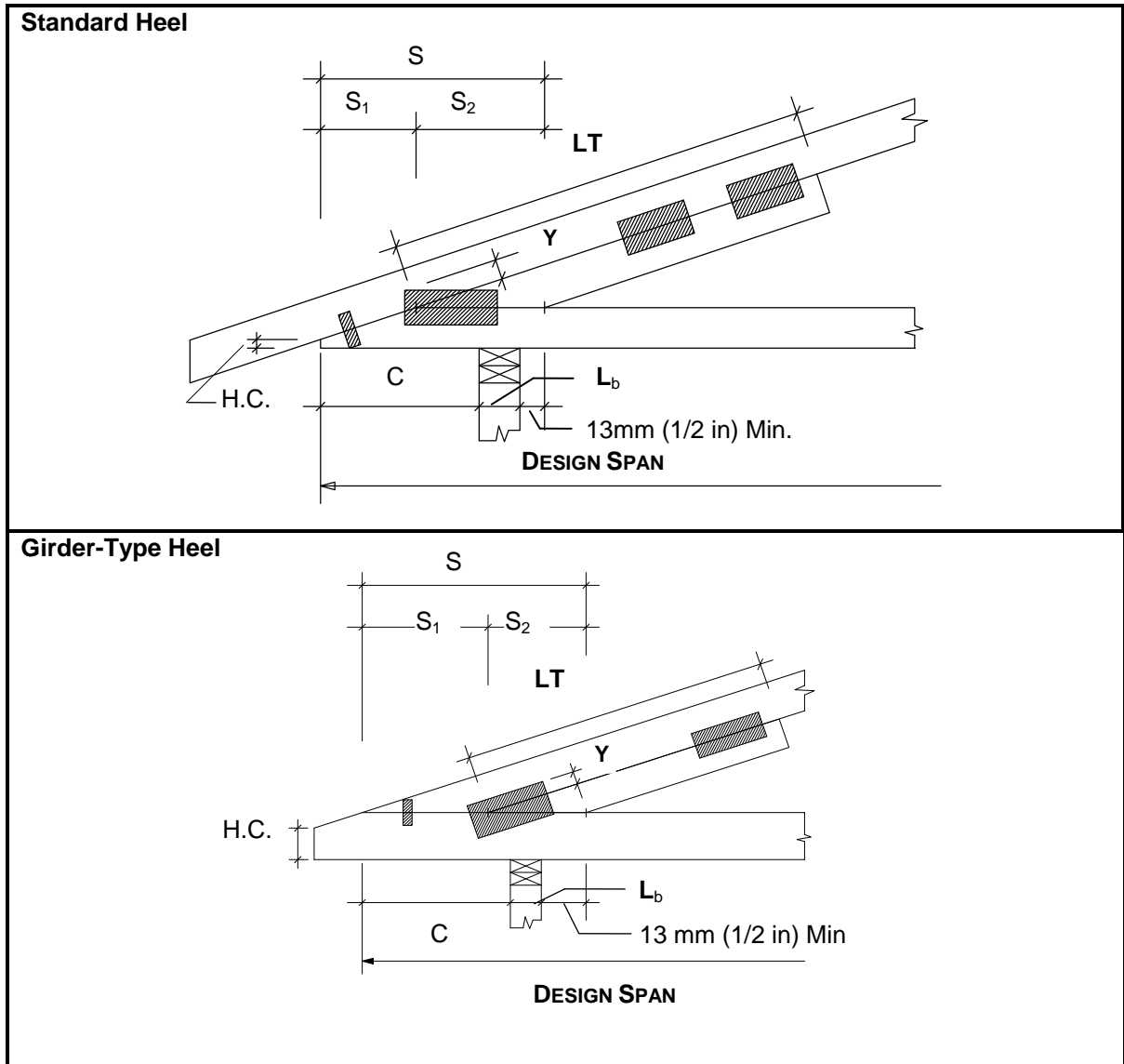

**MAXIMUM CANTILEVER "C" CALCULATION**

$$C(\text{mm}) = S_1(\text{mm}) + S_2(\text{mm}) - (L_b(\text{mm}) + 13 \text{ mm})$$

$$C(\text{in}) = S_1(\text{in}) + S_2(\text{in}) - (L_b(\text{in}) + 1/2 \text{ in})$$

- Notes:**
1. Maximum value of  $S_2$  is limited by maximum reinforcing member size 38x184 (2x8)
  2.  $LT$  = Minimum of one half the length of top chord panel
  3.  $Y$  = Minimum of 25 mm (1 in)

**A. 4 SHORT CANTILEVERS: DETAIL WITH PARTIAL BOTTOM CHORD REINFORCING MEMBER (PARTIAL BOTTOM CHORD SLIDER)**

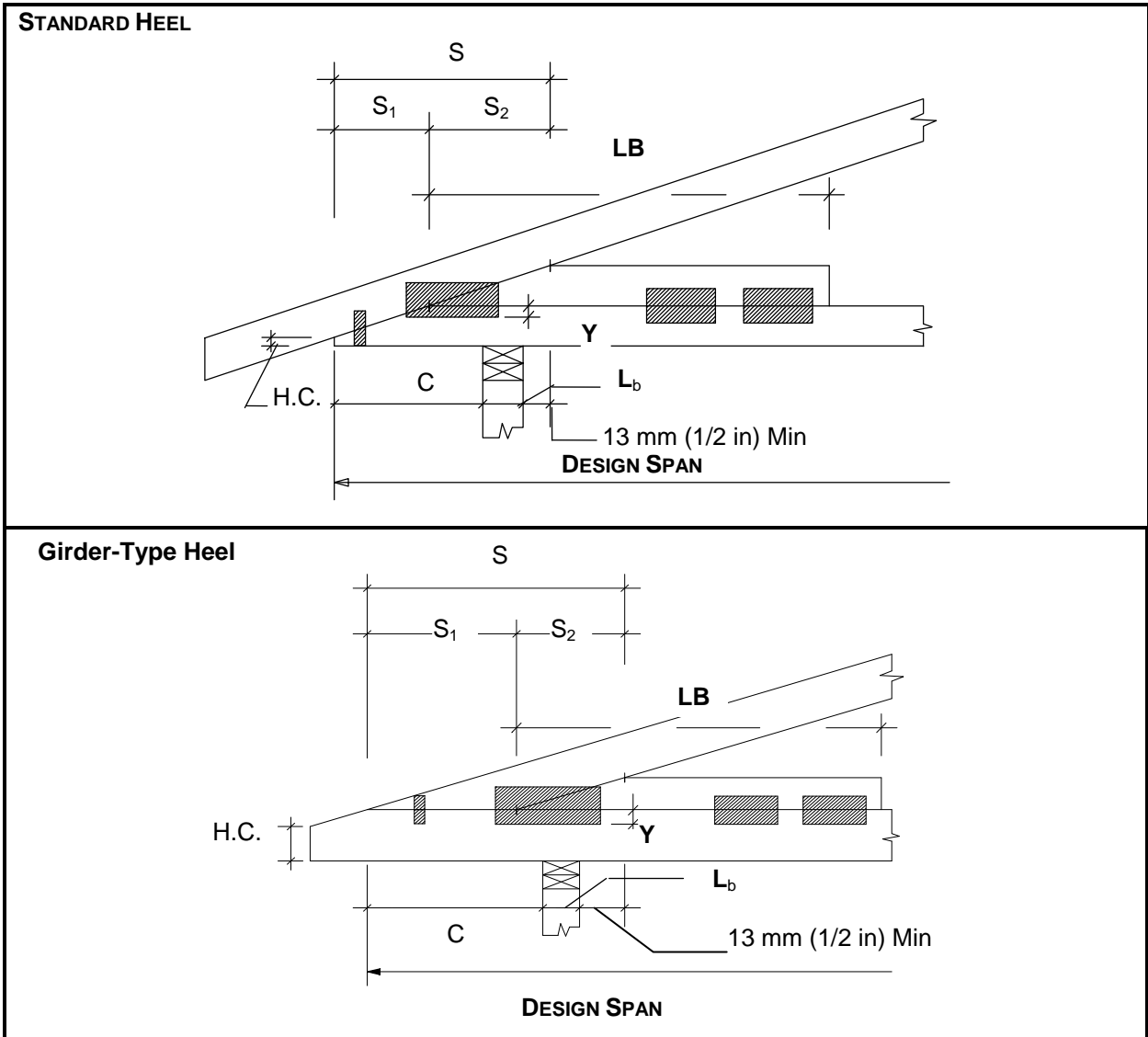

**MAXIMUM CANTILEVER "C" CALCULATION**

$$C(\text{mm}) = S_1(\text{mm}) + S_2(\text{mm}) - (L_b(\text{mm}) + 13 \text{ mm})$$

$$C(\text{in}) = S(\text{in}) + S_2(\text{in}) - (L_b(\text{in}) + 1/2 \text{ in})$$

- Notes:
1. Maximum value of  $S_2$  is limited by maximum reinforcing member size 38x184 (2x8)
  2. LB = Minimum of two thirds the length of bottom chord panel
  3. Y = Minimum of 25 mm (1 in)

A. 5 HEEL CUTS

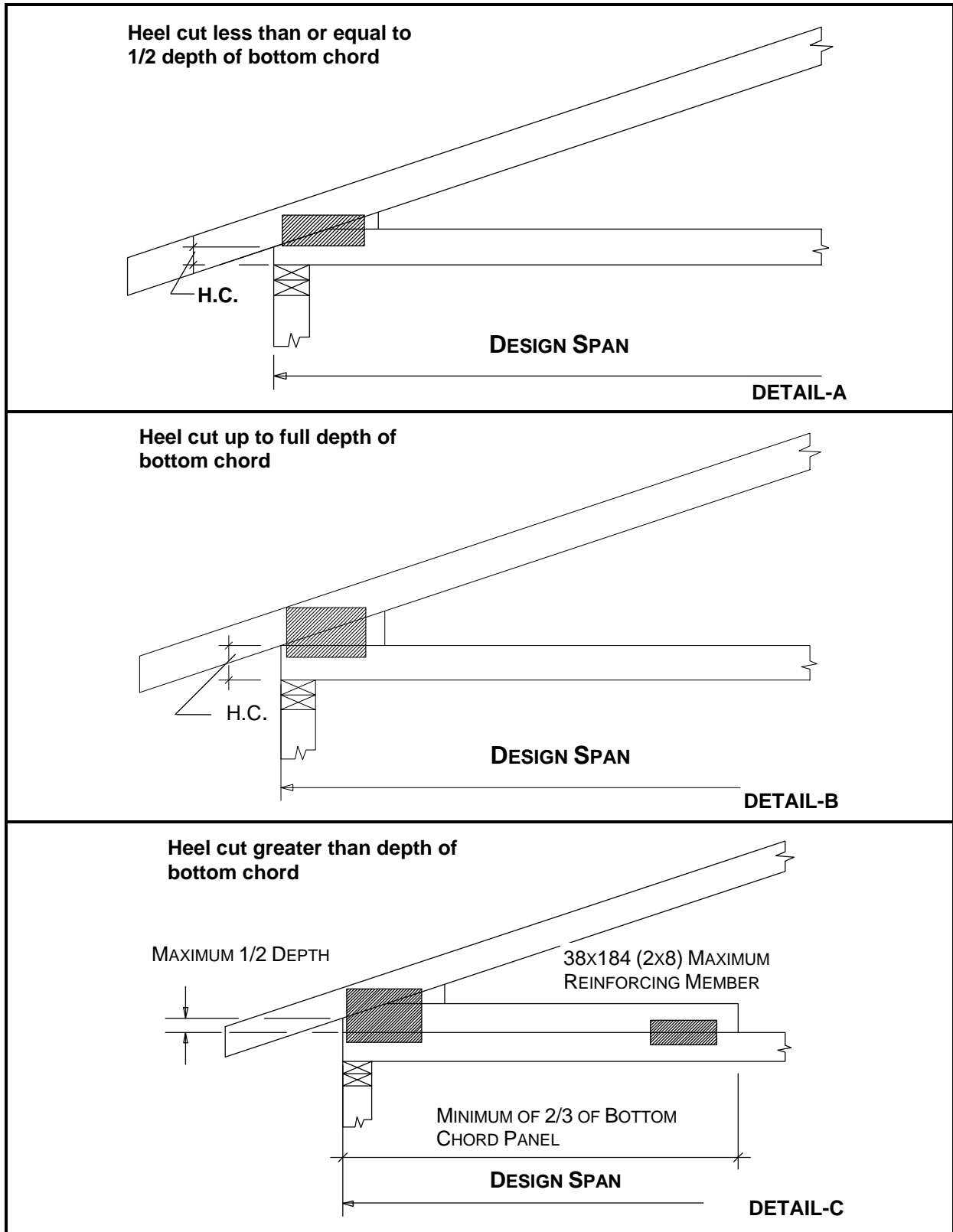

**A.6 SUPPLEMENTARY NOTES FOR DESIGN OF SHORT CANTILEVERS AND HEEL CUTS****1. GENERAL**

- a. Design span is always out to out of bottom chord for standard details.
- b. The sum of cantilever lengths shall not exceed 25% of span between bearings.
- c. Maximum cantilever shall not exceed 1372 mm (4'-6").
- d. The TPIC standard procedures for plating heel joints shall apply. i.e. Reduction of grip value with slope increase.
- e. Partial reinforcing members used with short cantilevers and heel cuts are limited in scope to trusses designed under Section 4.4.13. The reinforcing members shall be designed for top or bottom chord forces as applicable. For all other applications these cantilevers and heel cuts must be accomplished by full length reinforcement of the appropriate chord and limitations of cantilever length, reinforcement size, species, grade and, plating to be determined by analysis.

**2. SHORT CANTILEVER**

- a. All details:  
Maximum values of 'C' must be calculated for specific slope and heel cut as shown on the details.
- b. Detail without reinforcing.  
Plate heel for actual chord force. Tie plate is recommended for long scarf cuts.
- c. Detail with wedge reinforcing.  
Plate heel for actual forces. Tie plates are always required with the wedge. Total area of tie plates on chords shall be 20% of required area of heel plate on corresponding chord.
- d. Detail with chord reinforcing:
  - i. Plates joining reinforcing member to parallel chord shall provide sufficient grip and shear length to transfer full chord force to reinforcing member. Where only one plate is used, it shall be designed for 1.20 times chord force.
  - ii. Heel shall be designed as per standard heel procedures. Reinforcing member may be considered as top or bottom chord as applicable. There shall be a minimum of 25 mm (1 in) overlap as shown in sketches.
  - iii. Where plating and scarf permit, the reinforcing member may form part of the heel cut.
  - iv. Tie plates are recommended for long scarfs.

**3. HEEL CUTS**

- a. Detail A.  
Heel cut less than or equal to 6mm (1/4 in.) may be considered as zero heel cut. Plate for full chord forces.
- b. Detail B.  
Plate heel to resist full chord forces at 1/2 bottom chord depth with linear interpolation to twice the full chord forces up to the full depth of bottom chord.
- c. Detail C.  
Plate heel for full chord forces. Plate design for connecting reinforcing member to parallel chord shall be as per 2d.i. above.

**B.1 TRUSS-TO-TRUSS CONNECTION**

Minimum nail length	76 mm (3.00")
Minimum nail diameter	3.66 mm (0.144")
Lumber Grade	Spruce-Pine-Fir
Minimum nail spacing parallel to grain (a)	64 mm (2.50")
Minimum nail spacing from End distance parallel to grain (b)	45 mm (1.75")
Minimum nail spacing perpendicular to grain (c)	32 mm (1.25")
Minimum nail spacing from edge distance perpendicular to grain (d)	19 mm (0.75")

Maximum kN/m (PLF) apply only to nails as defined in CSA B111.

<b>MEMBER DEPTH mm (inches)</b>	<b>MAXIMUM NO. OF ROWS</b>	<b>MINIMUM * NO. OF ROWS</b>
64 (2.5)	1	1
89 (3.5)	2	1
114 (4.5)	2	1
140 (5.5)	3	2
184 (7.25)	4	2
235 (9.25)	5	3
286 (11.25)	6	3

\* For web nailing, use minimum number of rows stated in table and a surface nail spacing of 150 mm (6") o.c.

**Table B.1.1 Nail Spacing and Maximum Number of Rows.**

**TABLE B.1.2 MAXIMUM kN/m (PLF) FOR 2 PLY GIRDER  
WITH 3" NAILS AND S-P-F LUMBER**

NUMBER OF ROWS	SURFACE NAIL SPACING, mm (inches)		
	305 (12)	152 (6)	102 (4)
1	4.64 (318)	9.28 (636)	13.92 (954)
2	9.28 (636)	18.56 (1272)	27.84 (1908)
3	13.92 (954)	27.84 (1908)	41.77 (2862)
4	18.56 (1272)	37.13 (2544)	55.69 (3816)
5	23.20 (1590)	46.41 (3180)	69.61 (4770)
6	27.84 (1908)	55.69 (3816)	83.53 (5724)

- NOTE:
- 1) Load duration factor for "Standard Term" loading has been used in the computation of data in the table.
  - 2) If 3-inch power driven nails (0.120" dia) are to be substituted for 3-inch common wire nails then reduce the maximum kN/m (or PLF) to be transferred by a factor of 0.71.
  - 3) These tables are based on seasoned untreated lumber.

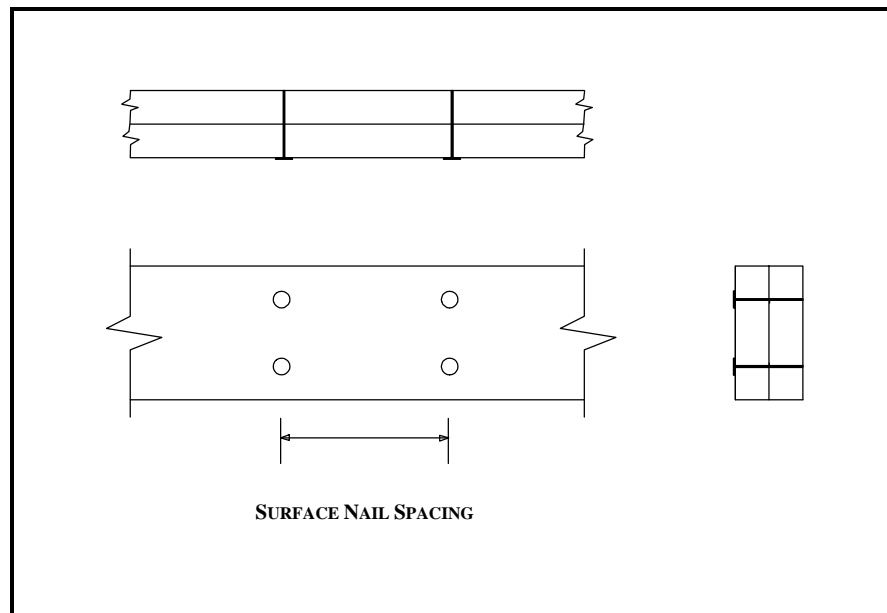

**Figure B.1.2 Nailing Pattern for 2-Ply Girder**

**TABLE B.1.3 MAXIMUM kN/m (PLF) FOR 3 PLY GIRDER  
WITH 3" NAILS AND S-P-F LUMBER**

NUMBER OF ROWS	SURFACE NAIL SPACING, mm (inches)		
	305 (12)	152 (6)	127 (5) *
1	3.48 (239)	6.96 (477)	8.35 (572)
2	6.96 (477)	13.92 (954)	16.71 (1145)
3	10.44 (716)	20.88 (1431)	25.06 (1717)
4	13.92 (954)	27.84 (1908)	33.41 (2290)
5	17.40 (1193)	34.81 (2385)	41.77 (2862)
6	20.88 (1431)	41.77 (2862)	50.12 (3434)

\* Inner ply rows should be offset for spacing

- NOTE:
- 1) Load duration factor for "Standard Term" loading has been used in the computation of data in the table.
  - 2) If 3-inch power driven nails (0.120" dia) are to be substituted for 3-inch common wire nails then reduce the maximum kN/m (or PLF) to be transferred by a factor of 0.71.
  - 3) These tables are based on seasoned untreated lumber.

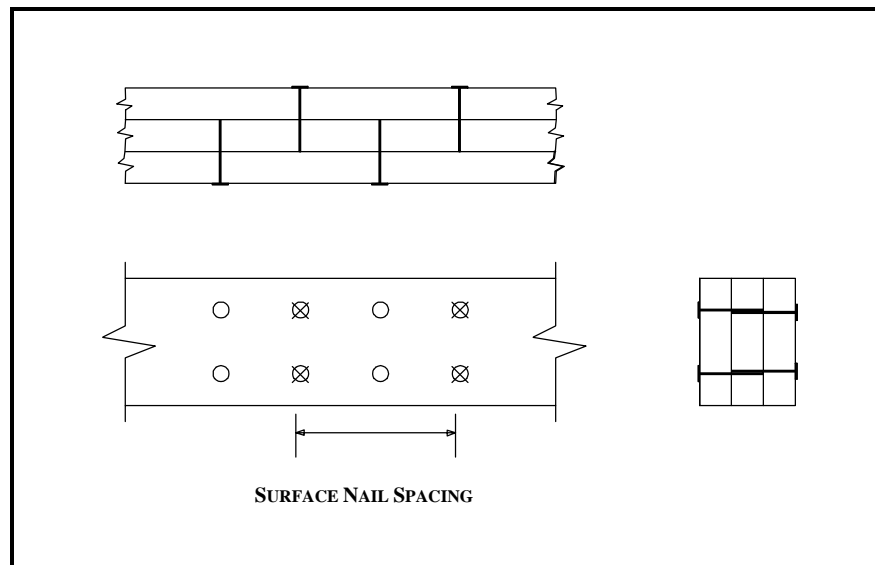

**Figure B.1.3 Nailing Pattern for 3-Ply Girder**

**TABLE B.1.4 MAXIMUM kN/m (PLF) FOR 4 PLY GIRDER  
WITH 3" NAILS AND S-P-F LUMBER**

NUMBER OF ROWS	SURFACE NAIL SPACING, mm (inches)		
	305 (12)	152 (6)	127 (5) *
1	3.09 (212)	6.19 (424)	7.43 (509)
2	6.19 (424)	12.38 (848)	14.85 (1018)
3	9.28 (636)	18.56 (1272)	22.28 (1526)
4	12.38 (848)	24.75 (1696)	29.70 (2035)
5	15.47 (1060)	30.94 (2120)	37.13 (2544)
6	18.56 (1272)	37.13 (2544)	44.55 (3053)

\* Inner ply rows should be offset for spacing

- NOTE:
- 1) Load duration factor for "Standard Term" loading has been used in the computation of data in the table.
  - 2) If 3-inch power driven nails (0.120" dia) are to be substituted for 3-inch common wire nails then reduce the maximum kN/m (or PLF) to be transferred by a factor of 0.71.
  - 3) These tables are based on seasoned untreated lumber.

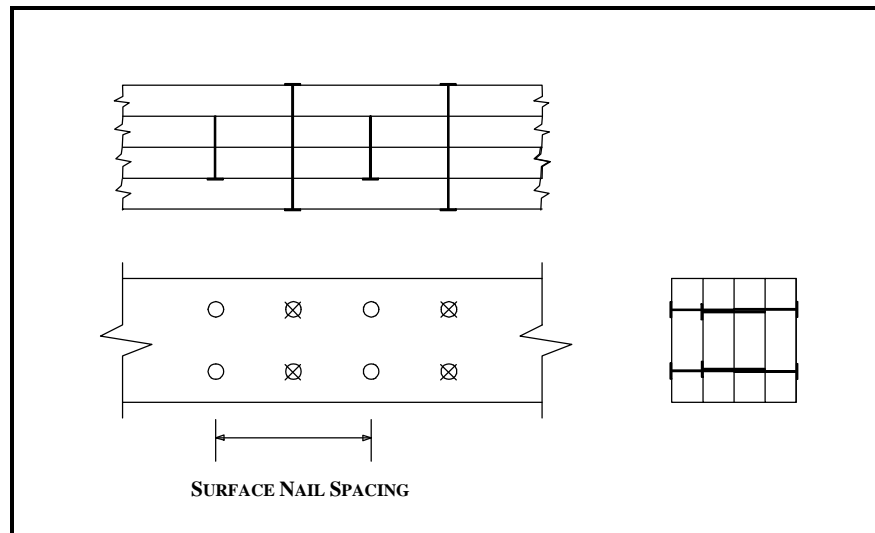

**Figure B.1.4 Nailing Pattern for 4-Ply Girder**

Supplementary Notes:

In addition to nailing, all chords of 4 and 5 ply girders must be bolted together with 13 mm (0.5") ASTM A307 Grade A bolts and washers, 1 bolt per panel.

**TABLE B.1.5 MAXIMUM kN/m (PLF) FOR 5 PLY GIRDER  
WITH 3" NAILS AND S-P-F LUMBER**

NUMBER OF ROWS	SURFACE NAIL SPACING, mm (inches)		
	305 (12)	152 (6)	127 (5) *
1	2.90 (199)	5.80 (398)	6.96 (477)
2	5.80 (398)	11.60 (795)	13.92 (954)
3	8.70 (596)	17.40 (1193)	20.88 (1431)
4	11.60 (795)	23.20 (1590)	27.84 (1908)
5	14.50 (994)	29.00 (1988)	34.81 (2385)
6	17.40 (1193)	34.81 (2385)	41.77 (2862)

\* Inner ply rows should be offset for spacing

- NOTE:
- 1) Load duration factor for "Standard Term" loading has been used in the computation of data in the table.
  - 2) If 3-inch power driven nails (0.120" dia) are to be substituted for 3-inch common wire nails then reduce the maximum kN/m (or PLF) to be transferred by a factor of 0.71.
  - 3) These tables are based on seasoned untreated lumber.

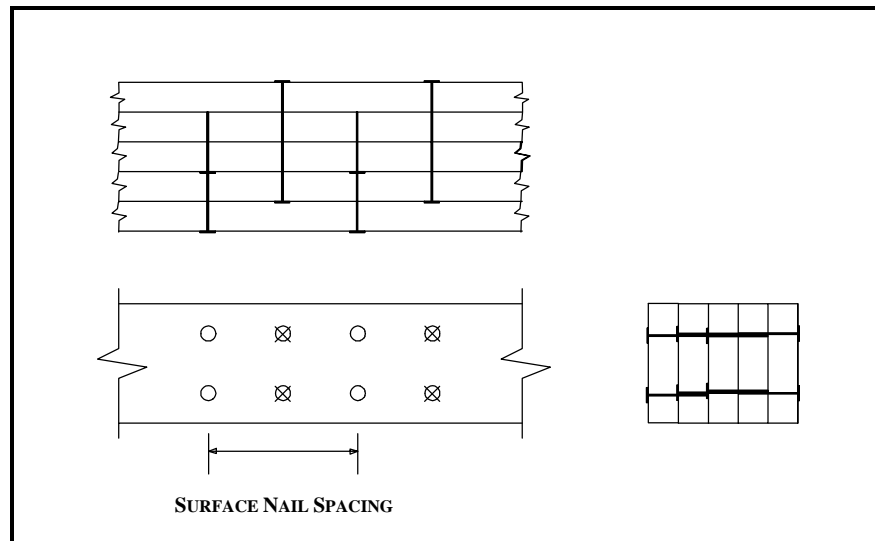

**Figure B.1.5 Nailing Pattern for 5-Ply Girder**

Supplementary Notes:

In addition to nailing, all chords of 4 and 5 ply girders must be bolted together with 13 mm (0.5") ASTM A307 Grade A bolts and washers, 1 bolt per panel.

**TABLE C.1 MAXIMUM WEB FORCE IN COMPRESSION KN (lbs) WITH ONE T-BRACE**

T-BRACE  Web  Web Length mm (inch)	38 x 89 (2 x 4)			
	38 x 64 (2 x 3)	38 x 89 (2 x 4)	38 x 114 (2 x 5)	38 x 140 (2 x 6)
915 (36)	27.75 (6240)	37.99 (8542)	47.83 (10750)	57.31 (12880)
1220 (48)	23.61 (5309)	31.61 (7107)	39.00 (8768)	45.89 (10320)
1525 (60)	18.95 (4260)	24.75 (5565)	29.90 (6723)	34.55 (7767)
1830 (72)	14.63 (3291)	18.70 (4205)	22.18 (4987)	25.24 (5674)
2135 (84)	11.11 (2498)	13.94 (3135)	16.30 (3666)	18.34 (4124)
2440 (96)	8.41 (1891)	10.41 (2342)	12.05 (2711)	13.45 (3024)
2745 (108)	6.41 (1442)	7.86 (1768)	9.03 (2031)	10.02 (2253)
3050 (120)	4.94 (1112)	6.02 (1354)	6.88 (1547)	7.59 (1708)

Supplementary Notes:

- Web and T-brace material to be S-P-F No. 2 or better.
- Load duration factor for Standard Term loading has been included in the computation of data in the table.
- Load sharing has been included as well.

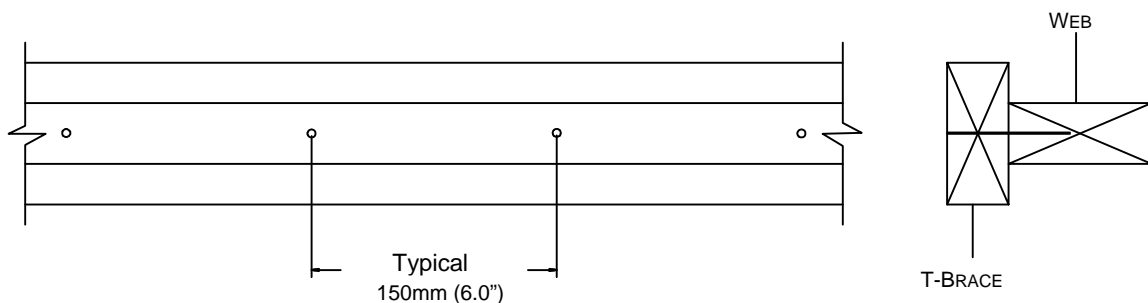

Nailing - 76mm (3") Common Wire Nails @ 150mm (6.0") O.C.

**Figure C.1.1 Nailing Pattern for T-Bracing on Single Ply Web**

TABLE D.1 TOP CHORD BEARING JOINT GUIDELINES FOR LUMBER ON EDGE

BEARING DETAIL SEE FIGURE	TOP CHORD SIZE	DIAGONAL SIZE MIN	MAXIMUM FACTORED ALLOWABLE REACTION	MAX ALLOWABLE GAP		
				mm (in)		
D.4.6.6.1	mm (in)	mm (in)	kN (lbs)	A	B	C
Detail 1	38 x 89 (2x4)	N/A	14.10 (3170)	13 (1/2)	13 (1/2)	3 (1/8)
Detail 2	38 x 89 (2x4)	N/A	14.10 (3170)	N/A	13 (1/2)	13 (1/2)
Detail 3,4	38 x 89 (2x4)	38 x 89 (2x4)	11.98 (2694)	13 (1/2)	13 (1/2)	3 (1/8)
	38 x 114 (2x5)	38 x 89 (2x4)	14.80 (3328)	13 (1/2)	38 (1-1/2)	3 (1/8)
	38 x 140 (2x6)*	38 x 89 (2x4)	17.62 (3962)	13 (1/2)	50 (2)	3 (1/8)
Detail 5	38 x 89 (2x4)	38 x 89 (2x4)	16.92 (3804)	13 (1/2)	N/A	6 (1/4)
	38 x 114 (2x5)	38 x 89 (2x4)	19.03 (4279)	13 (1/2)	N/A	6 (1/4)
	38 x 140 (2x6)*	38 x 89 (2x4)	21.15 (4755)	13 (1/2)	N/A	6 (1/4)
Detail 6,7	38 x 89 (2x4)	38 x 89 (2x4)	16.92 (3804)	N/A	13 (1/2)	13 (1/2)
		38 x 114 (2x5)	19.74 (4438)	N/A	13 (1/2)	13 (1/2)
		38 x 140 (2x6)	22.56 (5072)	N/A	13 (1/2)	13 (1/2)
	38 x 114 (2x5)	38 x 89 (2x4)	17.27 (3883)	N/A	38 (1-1/2)	13 (1/2)
		38 x 114 (2x5)	21.32 (4794)	N/A	38 (1-1/2)	13 (1/2)
		38 x 140 (2x6)	25.38 (5706)	N/A	38 (1-1/2)	13 (1/2)
	38 x 140 (2x6)*	38 x 89 (2x4)	17.62 (3962)	N/A	50 (2)	13 (1/2)
		38 x 114 (2x5)	22.91 (5151)	N/A	50 (2)	13 (1/2)
		38 x 140 (2x6)	28.20 (6340)	N/A	50 (2)	13 (1/2)

\* Or Greater

Note: Maximum factored reactions are for Spruce-Pine-Fir and D. Fir Chords.

**FIGURE D.1 TYPICAL TOP CHORD BEARING JOINT GUIDELINES FOR LUMBER ON EDGE**

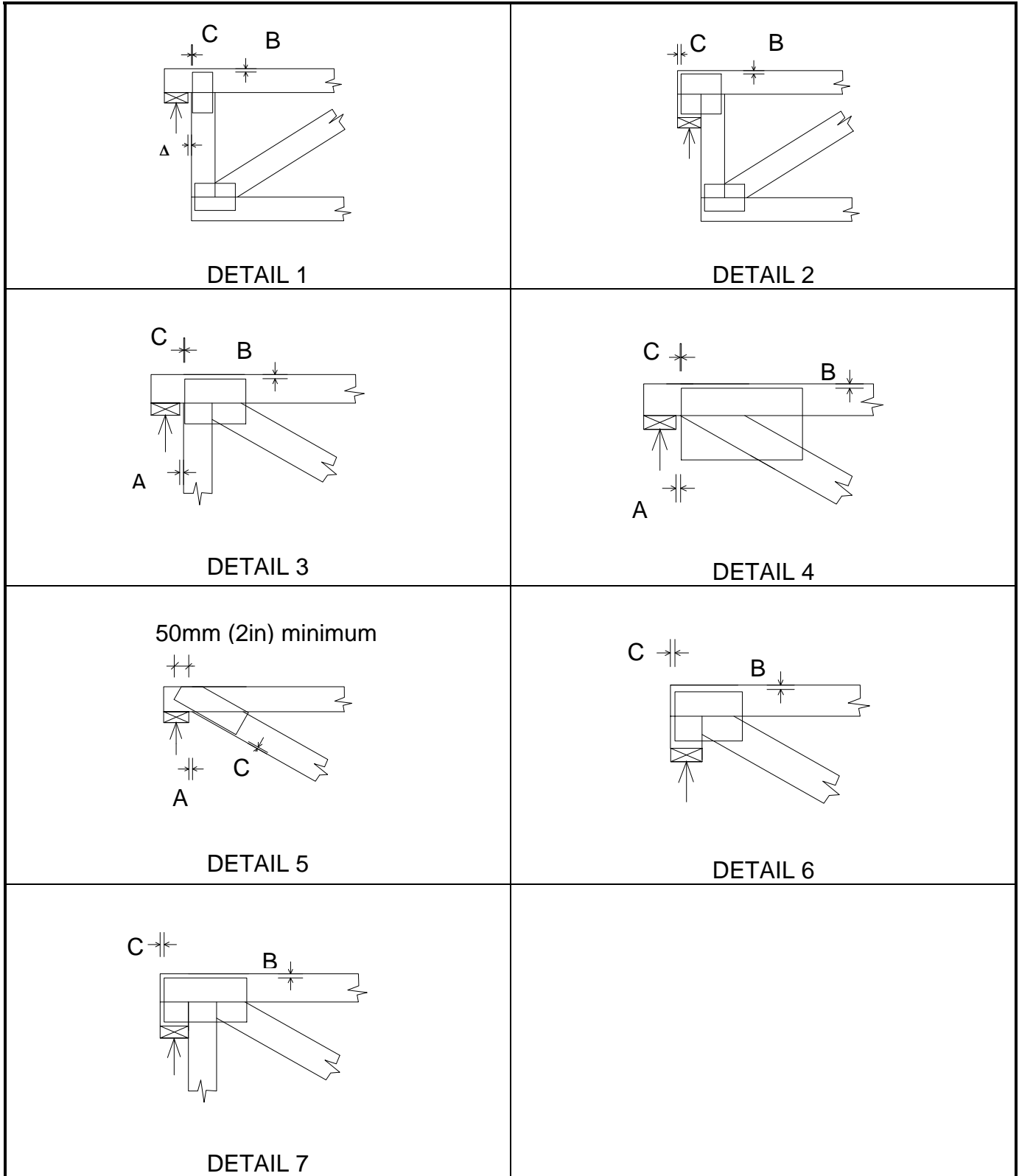
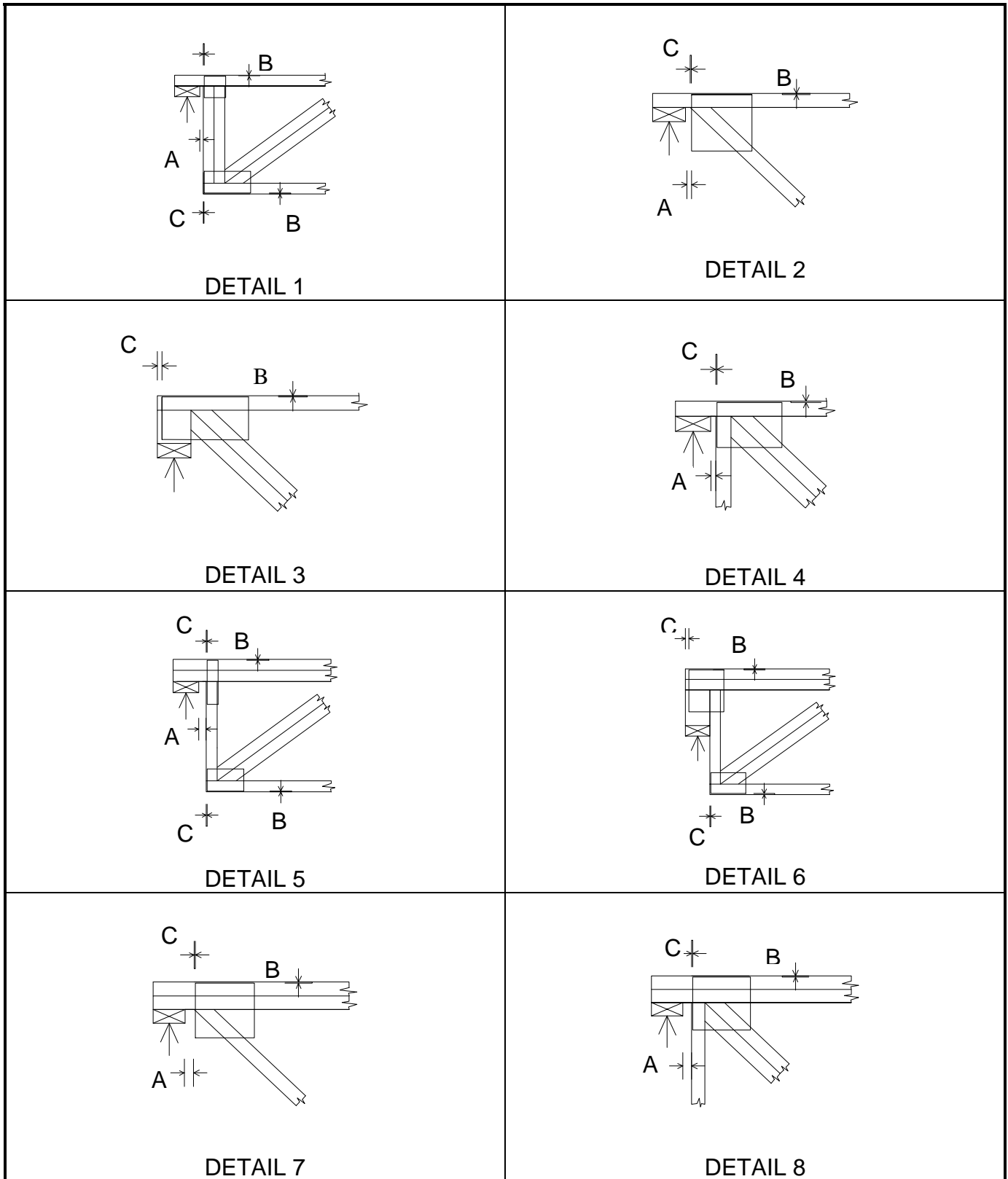

**TABLE D.2 TOP CHORD BEARING JOINT GUIDELINES FOR LUMBER ON FLAT**

TOP CHORD BEARING TYPE AS SHOWN IN FIGURE D.4.6.6.2		MAXIMUM FACTORED ALLOWABLE REACTION  kN (lbs)	MAX ALLOWABLE GAP mm (in)		
			A	B	C
Single Top Chord  4 x 2	Detail 1,2	4.23 (951)	13 (1/2)	3 (1/8)	3 (1/8)
	Detail 3	11.28 (2536)	N/A	3 (1/8)	13 (1/2)
	Detail 4	4.23 (951)	13 (1/2)	3 (1/8)	3 (1/8)
Double Top Chord  4 x 2	Detail 5, 7, 8	11.28 (2536)	13 (1/2)	3 (1/8)	3 (1/8)
	Detail 6	11.28 (2536)	N/A	3 (1/8)	13 (1/2)
	Detail 5, 6 (at B.C)		N/A	3 (1/8)	3 (1/8)
Double Top Chord  3 x 2	Detail 7, 8	8.06 (1811)	13 (1/2)	3 (1/8)	3 (1/8)
Double Top Chord  4 x 2	Detail 9,10	28.20 (6340)	N/A	3 (1/8)	13 (1/2)

Note: Maximum factored reactions are for Spruce-Pine-Fir and D. Fir Chords

**FIGURE D.2 TYPICAL TOP CHORD BEARING JOINT GUIDELINES FOR LUMBER ON FLAT**

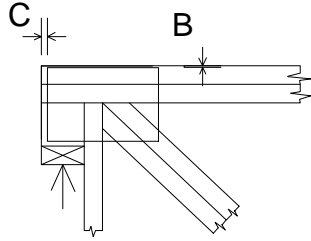
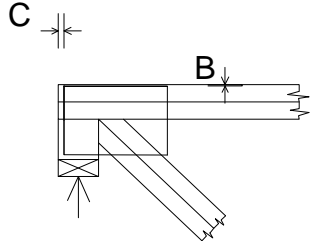

**FIGURE D.2 TYPICAL TOP CHORD BEARING JOINT GUIDELINES FOR LUMBER ON FLAT**

 <p style="text-align: center;">DETAIL 9</p>	 <p style="text-align: center;">DETAIL 10</p>

## E.1 CORROSION PROTECTION FOR METAL CONNECTOR PLATES

1. For metal connector plates used in unusual environmental conditions, or exposed to the weather, additional corrosion resistant protection for the metal connector plates shall be installed when such conditions are identified by the building designer/engineer.
2. Galvanized G 90 metal connector plates subject to environments described above shall be painted with one coat of one of the following combinations:
  - a) Epoxy-Polyamide Primer (SSPC-Paint22)
  - b) Coal-Tar Epoxy-Polyamide Black or Dark Red Paint (SSPC-Paint 16)
  - c) Basic Zinc Chromate-Vinyl Butyral Wash Primer (SSPC-Paint 27) and cold applied Asphaltic Mastic (Extra Thick Film) Paint (SSPC-Paint 12)
  - d) Any other coating or treatment acceptable to the building designer/engineer
3. All coatings shall be brush applied to the embedded metal connector plates at the jobsite during or after truss installation. Embedded metal connector plates shall be free of dirt and oil prior to coating application. In addition, all of the Manufacturer's recommendations for application of products used must be followed implicitly.

Note: To the best of industry knowledge these products will extend the serviceable life of the truss connector plate under conditions described in 1. above.

No warranty or guarantee, other than that offered by the manufacturers of these products is expressed or implied. Severe corrosive conditions may require maintenance of these protective coatings as part of the standard building maintenance program.

## F.1 SHEAR PLATE DESIGN FOR GIRDER TYPE HEEL JOINT

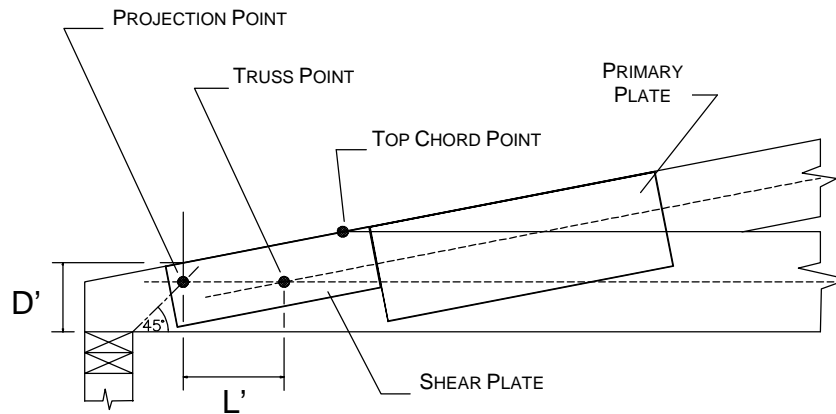

Truss Point - the intersection of the centreline of top chord and the centreline of bottom chord.

Projection Point - the intersection of the forty five degree line from the inside edge of the bearing and the centreline of bottom chord.

Top Chord Point - the beginning point of the top chord scarf.

### Shear Plate Requirements:

A shear check is required when the projection point is closer to the end of the truss than the truss point.

If  $P_A > P_W$ , then shear plates are required.

Where

$P_A$	=	The factored shear load at the girder heel, N (lbs)
$P_A$	=	$\frac{1.5RL'}{D'}$
R	=	Reaction N (lbs)
$L'$	=	Distance between projection point and truss point, mm (in)
$D'$	=	Lumber depth at projection point, mm (in)
$P_W$	=	The factored shear resistance of the lumber without plate, N (lbs)
$P_W$	=	$\phi F_v t n L'$
$\phi$	=	0.9
$F_v$	=	$f_v K_D K_{Hv} K_{Sv} K_T K_{Zv}$
t	=	Lumber thickness per ply, mm (in)
$f_v$	=	specified strength in shear, MPa (Psi)
n	=	Number of plies
$K_D$	=	Load duration factor
$K_{Hv}$	=	Load sharing factor for shear
$K_{Sv}$	=	Service condition factor for shear
$K_T$	=	Treatment factor
$K_{Zv}$	=	Size factor for shear

**Shear Plate Design:**

The shear plate must be sized and placed about the centreline of bottom chord to cover the distance  $L'$  such that:

- i) Area of the shear plate above or below the centreline of bottom chord must be capable of resisting the net shear force at the girder heel.

$$\text{Net Shear Force} = \frac{P_A - P_W}{n}$$

- ii) The length of the shear plate along the centreline of bottom chord must be such that the shear capacity of the plate, along the centreline of bottom chord, is greater than or equal to the net shear force at the girder heel. The shear length as calculated must not be less than  $L'$ .

**Notes:**

1. Where the primary plate interferes with the placement of the secondary shear plate then the primary plate must be specified long enough to provide the required grip and metal shear capacity due to the net shear force.
2. The tapered depth of the bottom chord at the inside edge of bearing should not be less than half the bottom chord size or 100mm (4 in), whichever is greater.
3. An additional moment check should be carried out due to extension of the bottom chord past the top chord. The moment to be used for this check is the overall span reaction times the distance from the inside edge of the bearing to the top chord point.

## **G MANUFACTURING AND MATERIAL VARIANCES**

### **G.1 SCOPE**

The purpose of this appendix is to establish minimum allowances to be used with the TPIC 2011 design procedures to account for material defects and variances in workmanship. It is the responsibility of the manufacturer to adjust these allowances for trusses that cannot be manufactured within the limits described in this appendix.

### **G.2 TRUSS SHOP DRAWING**

The truss shop drawings are the drawings provided to the plant personnel for the fabrication of each truss. They include enlarged joint details, tooth count requirements, cutting list, truss layout and/or jig location details.

### **G.3 MATERIALS**

#### **G.3.1 Lumber**

G.3.1.1 The lumber shall meet the criteria as described in TPIC Section 2.1 and be the size, species and grade (or better) specified on the Truss Shop Drawings.

G.3.1.2 Splits in any wood member caused by the manufacturing process shall not exceed those permitted in the grade and species of lumber used.

#### **G.3.2 Metal Connector Plates**

G.3.2.1 Metal connector plates shall meet the criteria as described in TPIC Section 2.2 and be of the gauge, type, manufacturer, width and length as specified on the Truss Shop Drawing.

### **G.4 PLATING**

Section 5.1 in the TPIC design procedures describes the conditions for which the design criterion for truss plates is based. To allow for minimum manufacturing and material variances the plate design criteria shall be adjusted to allow for plate misplacement and ineffective teeth. This section provides the procedure to adjust the design criteria to match that which is generally achievable in the manufacturing process.

#### **G.4.1 Tooth Effectiveness**

##### **G.4.1.1 Effective Teeth**

Effective teeth are teeth fully embedded normal to the surface of the lumber and into quality wood of the member.

##### **G.4.1.2 Ineffective Teeth**

Ineffective teeth are teeth that are improperly embedded and cannot resist loading. Examples include teeth located over wane, knot holes, loose or decayed knots, pitch pockets, unsound wood, holes and joint gaps or teeth that have been flattened before or during the pressing, or that have a

tooth embedment gap of 1.6 mm (1/16") or greater. Teeth located within the 13 mm (1/2") end and 6 mm (1/4") edge distances of the lumber are considered to be ineffective when the design is based upon the net area method.

#### G.4.1.3 Partially Effective Teeth

Teeth not completely embedded and can resist loading may be considered to be partially effective.

When a metal connector plate is installed in the connection area of lumber which contains tooth holes from a previously installed plate and where the wood is otherwise undamaged, metal connector plate teeth shall be considered 50% effective.

#### G.4.1.4 Minimum Effective Teeth

##### a. Lumber on Edge (Wide face plating)

The truss designer shall provide a minimum 10% reserve capacity in grip for each member to allow for ineffective teeth. This requirement may be met by limiting the grip JSI to 0.90 in each member. The required number of effective teeth in each member shown on truss shop drawings or in lists shall be calculated according to TPIC Section 5.1. This means that in the manufacturing process, the average number of effective teeth for both sides of the joint in any member shall never be less than the required number of teeth specified on the shop drawing. When averaging the effective teeth on both sides no one side shall have less than 85% of the specified effective teeth required.

##### b. Lumber on Flat (narrow face plating)

The truss designer shall provide a minimum 5% reserve capacity in grip for each member to allow for ineffective teeth. This requirement may be met by limiting the grip JSI to 0.95 in each member. The required number of effective teeth in each member shown on truss shop drawings or in lists shall be calculated according to TPIC Section 5.1. This means that in the manufacturing process, the average number of effective teeth for both sides of the joint in any member shall never be less than the required number of teeth specified on the shop drawing. When averaging the effective teeth on both sides no one side shall have less than 85% of the specified effective teeth required.

**Joint Stress Index:** The Joint Stress Index (JSI) is the ratio of the calculated force in a member to the lateral resistance of the teeth in that member. Example: If a member has a design force of 4.0 kN (900 lbs) in it and the teeth of the connector plate has a lateral resistance of 4.45 kN (1000 lbs), the JSI = 0.90.

#### G.4.1.5 Tooth Flattening

After pressing, teeth are considered flattened and ineffective if 1/4 or greater of the tooth is visible within the tooth slot. A tooth shall also be considered flattened if the surface of the wood has raised (i.e., wood lifted up beyond its normal surface plane) within the tooth-slot opening of the metal connector plate.

Sketch Showing Flattened Teeth

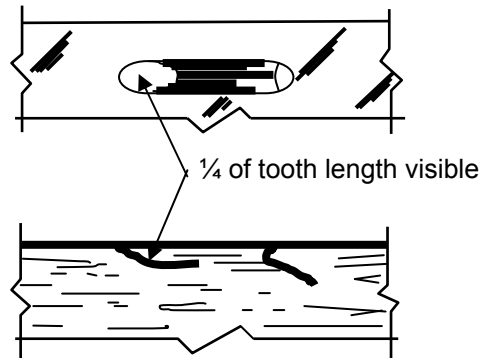

Both teeth are considered ineffective within a tooth slot.

G.4.1.6 Tooth Embedment Gap

After pressing, all teeth of each connector plate shall be completely embedded in each wood member. Teeth with an embedment gap of less than .8 mm (1/32") shall be considered effective. Teeth with a gap equal to or greater than 1.6 mm (1/16") shall be considered ineffective. Teeth with a gap between .8 mm (1/32") and 1.6 mm (1/16") shall be considered to be 60% effective.

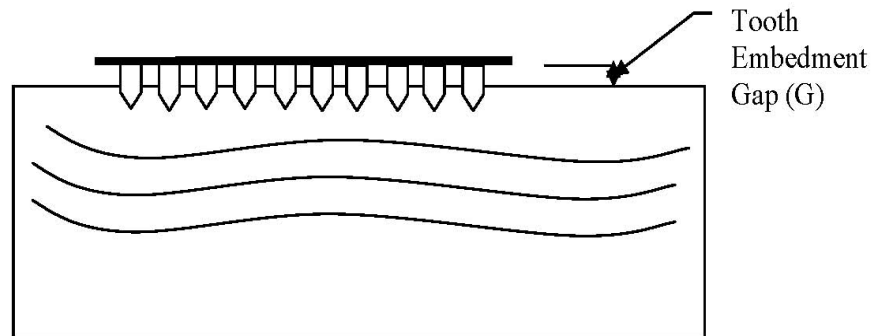

Tooth Effectiveness Table – Embedment Gap

Tooth Embedment Gap (G)	Tooth Effectiveness
0 mm < G < .8 mm (0" < G < 1/32")	100%
.8 mm ≤ G < 1.6 mm (1/32" ≤ G < 1/16")	60%
G ≥ 1.6 mm ( G ≥ 1/16")	0%

## G.4.2 Plate Placement Tolerances

### a. Lumber on Edge

During the truss manufacturing process, plates shall be positioned according to the Truss Shop Drawing and should be placed within the 6 mm ( $\frac{1}{4}$ " ) plate placement translation tolerance and within the plus and minus five degree ( $\pm 5^\circ$ ) plate rotation tolerance. In no case shall the positioning decrease the number of effective teeth in any member to less than the minimum number required for that member.

### b. Lumber on Flat

During the truss manufacturing process, plates shall be positioned according to the Truss Shop Drawing and should be placed within the 3 mm ( $\frac{1}{8}$ " ) plate placement translation tolerance. In no case shall the positioning decrease the number of effective teeth in any member to less than the minimum number required for that member. Due to relative ease of locating plates parallel to and near the edge of lumber, no allowance for rotational misplacement is required.

### G.4.2.1 Translation

#### a. Lumber on Edge

The truss designer shall use a minimum plate placement translation tolerance of 6 mm ( $\frac{1}{4}$ " ) parallel and perpendicular to the plate axis. The designer shall select a plate size and placement for each joint that resists the lateral forces in each member. The plate shall then be shifted by 6 mm ( $\frac{1}{4}$ " ) up, down, left, right, up and to the left, up and to the right, down and to the left, and down and to the right, and shall be checked to verify that a JSI of 0.90 is not exceeded in any member.

#### b. Lumber on Flat

The truss designer shall use a minimum plate placement translation tolerance of 3 mm ( $\frac{1}{8}$ " ) parallel and perpendicular to the plate axis. The designer shall select a plate size and placement for each joint that resists the lateral forces in each member. The plate shall then be shifted by 3 mm ( $\frac{1}{8}$ " ) up, down, left, right, up and to the left, up and to the right, down and to the left, and down and to the right, and shall be checked to verify that a JSI of 0.95 is not exceeded in any member.

### G.4.2.2 Rotation

#### a. Lumber on Edge

The truss designer shall also use a minimum plate placement rotation tolerance of plus and minus five degrees ( $5^\circ$ ) about the centre of the connector plate. The designer shall select a plate size and placement for each joint that resists the lateral forces in each member. The plate shall then be rotated  $5^\circ$  clockwise and checked to verify that a JSI of 0.90 is not exceeded in any member. The plate shall then be rotated  $5^\circ$  counterclockwise from its original position and checked to verify that a JSI of 0.90 is not exceeded in any member. If the plate does not resist the force in any member, the plate size is increased and checked again for the two rotated ( $+ 5^\circ$  and  $-5^\circ$ ) positions.

#### b. Lumber on Flat

Due to relative ease of locating plates parallel to and near the edge of lumber, no allowance for rotational misplacement is required.

Note: In both the shifting and rotational checks these misplacements are limited to the outer boundaries of the truss. Translation and Rotation checks are done independent of each other.

G.4.2.3 Metal Effectiveness

The truss designer shall ensure the sum of the length or width of metal across each side of a joint shall adequately resist the shear or tension forces at the joint. This check also applies to each shifted location and rotated location using the appropriate shear and breaking values for these locations and actual length or width of metal across the joint.

All supplemental blocking such as wedges and splice blocks must be installed as per the Truss Shop Drawing.

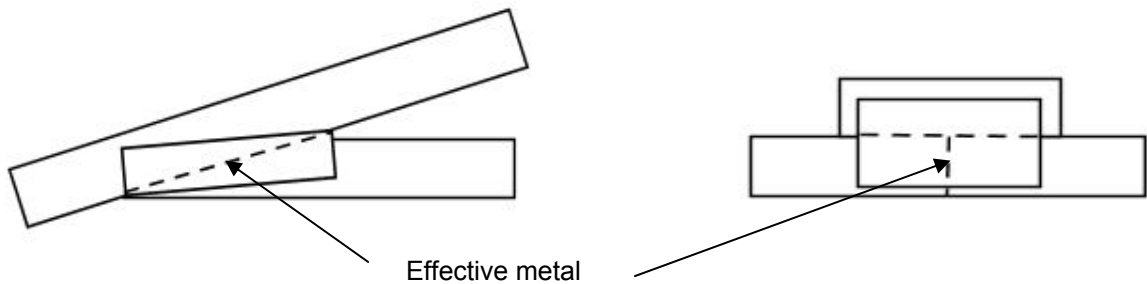

G.5 TRUSS ASSEMBLY

G.5.1 Member to Member Gaps

Members at each joint should have wood to wood bearing at each interface. Gaps in joints after pressing shall not exceed 1.6 mm (1/16 inch) for compression splices including pitch breaks and 3 mm (1/8 inch) for all other joints.

a)

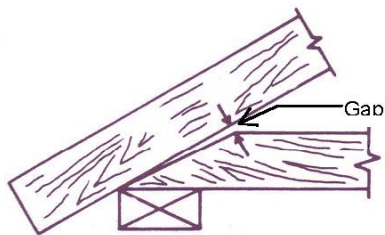

Gap between Top and Bottom Chords in heel joints shall not exceed 3 mm (1/8")

b)

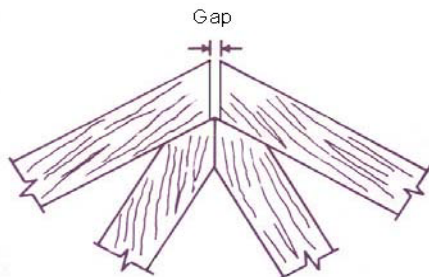

Gap between Top Chords in a Peak joint shall not exceed 1.6 mm (1/16")

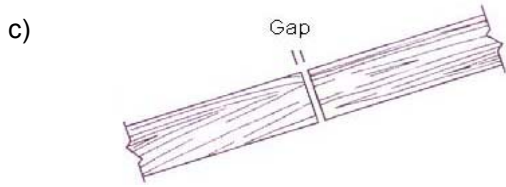

Gaps in Compression Splices shall not exceed 1.6 mm (1/16")

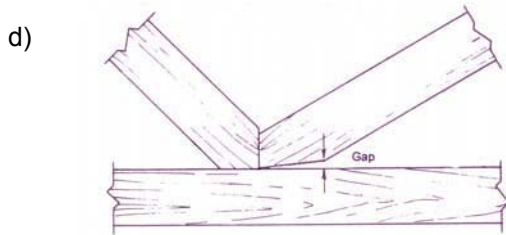

Gaps in interior webs shall not exceed 3 mm (1/8")

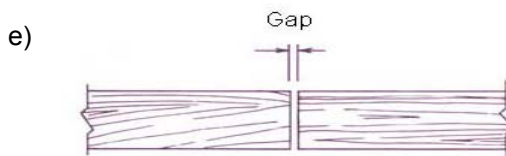

Gaps in Tension Splices shall not exceed 3 mm (1/8")

**G.5.2 Overall Truss Dimensions**

The dimensions of a completed truss if different from those as specified on the Truss Shop Drawing shall not exceed the differences shown in the following table:

Truss Dimensions	Maximum Difference between specified and measured dimensions
Length ≤ 9144 mm (30 feet)	6 mm (1/4")
Length > 9144 mm (30 feet)	13 mm (1/2")
Overall Height ≤ 1200 mm (4 feet)	3 mm (1/8")
Overall Height > 1200 mm (4 feet)	6 mm (1/4")
Left Heel/Stub Height	3 mm (1/8")
Right Heel/Stub Height	3 mm (1/8")
Left Overhang	3 mm (1/8")
Right Overhang	3 mm (1/8")

## **H.1 MINIMUM INFORMATION ON TRUSS DESIGN DRAWING**

Truss Design Drawings shall include, but not limited to, the information specified below:

1. Building code, CSA and TPIC Standard to which the drawing complies to.
2. Slope or depth, span and spacing.
3. Location of all joints and support locations.
4. Input and required bearing widths.
5. Software version number.
6. Specified loads, as applicable, shall include:
  - a. Top chord variable loads (including snow, live loads).
  - b. Top chord dead load.
  - c. Bottom chord live load due to limited accessibility.
  - d. Bottom chord dead load.
  - e. Wind loads
  - f. Other lateral loads, including drag strut loads.
  - g. Statement of whether special loading requirements have been checked including but not limited to unbalanced loading, minimum concentrated loads, etc.
  - h. All additional loads and their points of application as applicable.
7. Adjustments to wood member and metal connector plate design value for conditions of use.
8. Adjustments made to material strength due to load sharing.
9. Connection requirements for truss ply to ply.
10. Maximum factored reaction force and direction, including maximum factored uplift reaction forces where applicable.
11. Maximum CSI on top chord, bottom chord and webs.
12. Maximum un-factored reaction force and direction for each load type.
13. Metal connector plate type, manufacturer, size, and thickness or gauge, and the dimensioned location of each metal connector plate except where symmetrically located relative to the joint interface.
14. Size, species and grade for each wood member.
15. Calculated maximum vertical and horizontal deflection for variable load and total load as applicable.
16. Maximum axial tension and compression forces in the Truss members.
17. Fabrication Tolerance used per Appendix G.
18. Required Permanent Individual Truss Member Restraint location shall be shown for lateral bracing. Fastening of the lateral brace, T/I-brace, scab brace, L-brace shall be specified.
19. Drawing identification.
20. Design equation used for combined bending and compression member design.
21. Output error messages when design exceeds limits.