

TRUSS DESIGN PROCEDURES AND SPECIFICATIONS
FOR LIGHT METAL PLATE CONNECTED WOOD TRUSSES

Limit States Design

TPIC - 1996

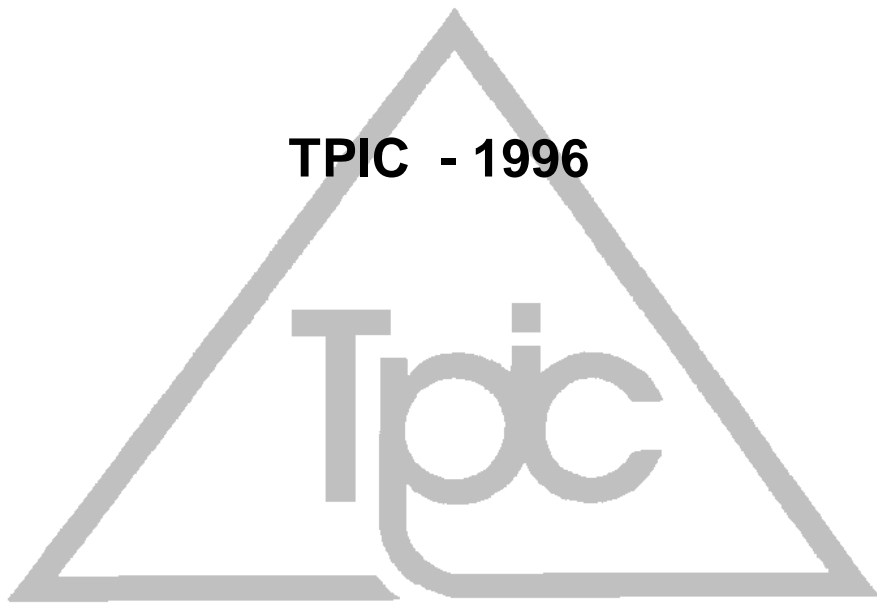

Truss Plate Institute
of Canada

TRUSS PLATE INSTITUTE OF CANADA (TPIC)

Full Members:

Alpine Systems Corporation
70 Moyal Court
Concord, Ontario
L4K 4R8

MiTek Canada, Inc.
100 Industrial Road
P.O. Box 1329
Bradford, Ontario
L3Z 2B7

Jager Industries Inc.
8835 Macleod Trail
Calgary, Alberta
T2H 0M3

Systemes ForeTruss Inc.
179 Blvd De L'Aeroport
Gatineau, Quebec
J8P 7G7

Span Truss Systems Inc.
1941 Gore Road
London, Ontario
N5W 6B9

Tee-Lok Corporation c/o
P.O. Box 687
Maple, Ontario
L0J 1E0

Associated Member :

Micro City Engineering Services Inc
RR#1 (2776 Highway #2)
PO Box 61
Glencoe, Ontario
N0L 1M0

DISCLAIMER

These recommendations are for the design of metal plate connected wood trusses that originate from the collective experience of leading technical personnel in the metal plate connected wood truss industry, but must, due to the nature of the responsibilities involved, be presented only as a guide for the use of a qualified engineer or designer. By publishing this booklet, the Truss Plate Institute of Canada and its member companies do not warrant the recommendations information contained herein as proper under all conditions and expressly disclaim any responsibility for damages arising from the use, application, or reliance on the recommendations and information contained herein. This standard does not preclude the use of materials, assemblies, structures or designs not meeting the criteria herein, when they demonstrate equivalent performance for the intended use to those specified in this standard.

FOREWARD

The purpose of this manual is to present data for design to those familiar with engineering procedures. It does not include information found in standard engineering textbooks which include derivation of formulas. It is not intended that these specifications illustrate all truss configurations or details thereof.

This specification covers materials, both lumber and steel, design procedures for members and joints, including minimum snow loads and minimum dead loads, and evaluation of connector plates.

This specification incorporates the most recent code changes, lumber and design standards and the latest generally accepted engineering procedures and methods. All previous editions of this specification are obsolete.

These specifications do not cover design for the complete structural system of a building. Suitable provisions must be made for adequate supports, cross bracing, wind loading, seismic loading, or other horizontal loading by those responsible for over-all building design.

The design methods contained within this specification are based on sound engineering judgement with specific reference to the National Standard of Canada (CSA 086.1-94) and the National Building Code of Canada 1995. A continuous program of research work is being carried out at various universities and testing laboratories to supplement and enhance this specification.

The purpose of the Truss Plate Institute of Canada is; to serve the needs of manufacturers of truss plates and wood trusses by representation on various committees of recognized organizations dealing with building codes and standards; to establish and promulgate standards for the design, manufacture and quality control of truss plates as may be required; to do all other things to foster and develop truss plate manufacturing and wood truss fabrication industries, consistent with law, and in the mutual interest of members of the organization.

HISTORY OF TPIC

Year 1971 National Building Code of Canada (1970) introduced new classifications and dimensions for lumber construction.

June 1971 Several major Canadian truss plate manufacturers convened for the purpose of creating the Truss Plate Institute of Canada.

May 1972 TPIC was incorporated under Canadian law and its constitution and by-laws adopted.

July 1973 Uniform testing procedures for metal truss plates were developed.

April 1974 CMHC and TPIC agreed on maximum span tables for publication in N.B.C.C.

Oct 1976 TPIC Testing procedures for truss plates were adopted as CSA Standard S347.

May 1977 CMHC recognized TPIC Design Procedures.

Jan 1981 3rd Edition of TPIC Design Procedure for Roof and Floor Trusses published.

Jan 1988 4th Edition of TPIC Design Procedure for Roof and Floor Trusses published.

1988 - 1995 A number of addendums, revisions and additional design procedures were added to TPIC 1988 to keep the industry abreast of the latest technical information.

Nov 1995 The publication, printing and distribution of the National Building Code of Canada introduces Reliability Based design procedures (Limit States design procedures). With Working Stress design procedures to be eliminated, truss testing at Forintek in Vancouver took place through 1993-1995.

Fall 1997 TPIC 1996 is published introducing truss design procedures and specifications for light metal plate connected wood trusses for Limit States Design.

DESIGN RESPONSIBILITIES

Truss Designer/Engineer - a design professional, individual or organization having responsibility for the design of individual metal plate connected wood truss components, including lateral bracing requirements to prevent buckling of individual truss members due to specified loads.

Building Designer/Engineer - a design professional, individual or organization, having responsibility for overall building design. Within the scope of wood trusses, the building designer / engineer, shall specify the following:

- (a) Design loads in accordance with various sections of the National and / or Provincial Building Codes.
- (b) Truss profile and intended support locations.
- (c) Vertical and horizontal deflection limits.
- (d) Moisture environment for intended end use.
- (e) Any special requirements to be considered in the truss design.
- (f) Additional loads from mechanical, electrical units, which may induce extra load to various truss members and their locations.

As this standard does not cover the design for the complete structural system of a building, the building designer / engineer shall provide the following in the design and detailing of the building:

- (a) Truss supports and anchorage accommodating horizontal, vertical or other reaction or displacement.
- (b) Permanent truss bracing to resist wind, seismic and any other lateral forces acting parallel or perpendicular to the plane of trusses.
- (c) Method of connection or anchorage of mechanical, electrical units to various truss members.

CONTENTS

1. GENERAL	1
1.1 Definitions	1
1.2 Abbreviations	2
1.3 Reference Publications	2
2. MATERIALS	4
2.1 Lumber Sizes and Grades	4
2.2 Steel	4
3. SPECIFIED LOADS	6
3.1 Definitions	6
3.2 Specified Live Loads	7
3.2.1 Housing and Small Buildings (Part 9 of NBCC95)	7
3.2.2 Commercial Roof Trusses (Part 4 of NBCC95)	7
3.2.3 Low Human Occupancy (Farm)	8
3.2.4 Residential Floor Trusses (Part 4 of NBCC95)	8
3.2.5 Commercial Floor Trusses (Part 4 of NBCC95)	8
3.3 Specified Dead Loads	9
3.3.1 Roof Dead Loads	9
3.3.2 Floor Dead Loads	9
4. MEMBER DESIGN PROCEDURE	10
4.1 Analogue	10
4.1.1 Analogue Joint Types	10
4.1.2 Analogue Points	10
4.1.3 Analogue Modifications	12
4.2 Strength and Serviceability Limit States	20
4.2.1 Method of Analysis	20
4.2.2 Strength Limit States	20
4.3 Specified Strengths	21
4.3.1 Visually Stress-Graded Lumber	21
4.3.2 Machine Stress-Rated and Machine Evaluated Lumber	21
4.3.3 Design Specified Strengths	21
4.3.4 Modification Factors	21
4.4 Strength and Resistance	24
4.4.1 Bending Moment Resistance	24
4.4.2 Shear Resistance	24
4.4.3 Compressive Resistance Parallel To Grain	25
4.4.4 Compressive Resistance Perpendicular To Grain	26
4.4.5 Tensile Resistance Parallel To Grain	27
4.4.6 Stress Index Due To Bending	27
4.4.7 Stress Index Due To Shear	27
4.4.8 Stress Index To Compression (Parallel to Grain)	28
4.4.9 Stress Index Due To Compression (Perpendicular to Grain)	28
4.4.10 Stress Index Due To Tension	28
4.4.11 Combined Stress Index Due To Tension & Bending	28
4.4.12 Combined Stress Index Due To Compression & Bending	28
4.4.13 Combined Stress Index Due To Compression & Bending (Modified Formula)	28
4.5 Serviceability Limit States	30

4.5.1	Serviceability Requirements (Allowable Deflections)	30
4.5.2	Permanent Deformation	31
4.5.3	Ponding	31
4.6	Special Design Considerations	32
4.6.1	Overhangs	32
4.6.2	Splices	32
4.6.3	Short Cantilevers and Heel Cuts	33
4.6.4	Girder Trusses (Single and Multi-Ply)	33
4.6.5	Truss Bracing	33
4.6.6	Top Chord Bearing Guidelines	33
5.	JOINT DESIGN PROCEDURES	34
5.1	General	34
5.2	Connector Plate Evaluation	35
5.3	Strength Limit States	36
5.3.1	General	36
5.3.2	Modification Factors	36
5.3.3	Ultimate Lateral Resistance	36
5.3.4	Tensile Resistance	37
5.3.5	Shear Resistance	38
5.3.6	Factored Resistance of Truss Plates	37
5.4	Serviceability Limit States	38
5.5	Member Joint Connections	39
5.5.1	Connection of Tension Members	39
5.5.2	Connection of Compression Members	39
5.5.3	Connection of Members for Shear	39
5.5.4	Combined Shear-Tension Resistance	39
5.5.5	Net Section Lumber Check (h')	40
5.5.6	Tension Perpendicular-to-Grain Considerations	41
5.5.7	Heel Joint Considerations	41
5.5.8	Chord Member Splice Considerations	42
5.5.8.1	General	42
5.5.8.2	Tension Splices	42
5.5.8.3	Compression Splices	42
5.5.8.4	Chord Member Splices - Moment Considerations	42
5.5.9.	Compression Perpendicular-to-Grain	43

APPENDIX

Appendix A

A.1	Short Cantilevers: Detail without Reinforcing	44
A.2	Short Cantilevers: Detail with Wedge Reinforcing	45
A.3	Short Cantilevers: Detail with Partial Top Chord Reinforcing	46
A.4	Short Cantilevers: Detail with Partial Bottom Chord Reinforcing	47
A.5	Heel Cuts	48
A.6	Supplementary Notes for Design of Short Cantilevers and Heel Cuts	49

Appendix B

B.1	Truss-to-Truss Connection	50
B.1.1	Nail Spacing and Maximum Number of Rows	50
B.1.2	Maximum kN/m (PLF) for 2 Ply Girder	51
B.1.3	Maximum kN/m (PLF) for 3 Ply Girder	52
B.1.4	Maximum kN/m (PLF) for 4 Ply Girder	53
B.1.5	Maximum kN/m (PLF) for 5 Ply Girder	54

Appendix C

C.1.1	Maximum Web Force in Compress kN (lb) with One T-brace	55
-------	--	----

Appendix D

D.4.6.6.1	Top Chord Bearing Joint Guidelines for Lumber on Edge	56
D.4.6.6.2	Top Chord Bearing Joint Guidelines for Lumber on Flat	58

Appendix E

E.1	Corrosion Protection for Metal Connector Plates	61
-----	---	----

Appendix F

F.1	Shear Plate Design for Girder Type Heel Joint	62
-----	---	----

ILLUSTRATIONS

Figures

4.1.2	Simple and Compound Analogue	13
4.1.2.1.A	Standard Heel Analogue	14
4.1.2.1.B	Girder Heel	14
4.1.2.1.C	Raised Heels	15
4.1.2.1.D	Short Cantilevered Heels	16
4.1.2.1.E	Short Cantilevered Heels	16
4.1.2.1.F	Short Cantilevered Heels	16
4.1.2.1.G	Short Cantilevered Heels	16
4.1.2.2	Pitch Break Joint	17
4.1.2.2.A	Mitre Cut Pitch Break Joint	17
4.1.2.2.B	Corner Joint	17
4.1.2.3	Splice Joint	18
4.1.2.4	Lapped Joint	18
4.1.2.5	Web Joints	18
4.1.2.6	Internal Joint	18
4.1.2.7	Tail Bearing Joint	18
4.1.2.8	Top Chord Bearing Details	19
4.1.2.9	Top Chord Bearing with End Vertical and Block	19
4.5.1.(4)	Truss Deflection Lengths	30
4.6.2.(2)	Kingpost and Queenpost Truss Configurations	32
5.1.(5)	Truss Plate Load and Grain Orientation	37
5.5.4	Shear - Tension Lengths and Angles	40
5.5.5	Typical h' Dimensions	40
5.5.9	Bearing Reinforcement with Connector Plates	43

Tables

2.2.(1)	ASTM Specification A653/A653M-94 for Structural Quality Sheet Steel	4
3.3.1	Minimum Dead Loads	9
4.3.4.(1)	Load Duration Factor, K_D	21
4.3.4.(2)	Service Condition Factor, K_S	22
4.3.4.(3)	Treatment Factor, K_T	22
4.3.4.(4)	System Factor, K_H	23
4.3.4.(5)	Size Factor, K_Z for Visually Graded Lumber	23
4.4.4.(4)	Size Factor for Bearing, K_{ZCP}	27
4.4.4.(5)	Length of Bearing Factor, K_B	27
4.5.1.(4)	Truss Deflection Limitations	31
5.1.(7)	Minimum Bite for Chords and Webs	35
5.3.2.(2)	Service Condition Factor, K_{SF}	36
5.3.2.(3)	Fire Retardant Treatment Factor for Truss Plates, K_T	36
5.5.7.(1)	Heel Joint Moment Factor, J_H	41

1. GENERAL

1.1 DEFINITIONS

BEARING	The structural support of the truss, usually load bearing walls, support beams, or truss hangers.
BOTTOM CHORD	A horizontal or inclined lumber member that establishes the lower edge of a truss.
CANTILEVER	The top and bottom chord section of a truss that extends freely beyond an exterior support.
CLEAR SPAN	The truss length measured from inside face to inside face of adjacent supports.
CONTINUOUS SHEATHING	The application of sheathing material to a truss chord, usually by nailing, such that the chord is in effect laterally braced continuously along its length.
DESIGN SPAN	The overall length of the truss analogue used in the structural analysis.
DRY SERVICE	A condition in which the average equilibrium moisture content over a year is 15% or less and does not exceed 19%.
HEEL JOINT	A joint on a truss at which the top and bottom chords intersect.
HEEL CUT	At the heel joint, a vertical cut at the outside edge of the truss bottom chord made to define design span.
LOAD SHARING SYSTEMS	A system consisting of 3 or more essentially parallel trusses spaced not more than 610 mm (1220 mm for Low Human Occupancy) apart and so arranged that they mutually support the applied load.
LOW HUMAN OCCUPANCY	(As applying to farm buildings) A building with an occupant load of not more than one person per 40 sq m during normal use.
LUMBER ON EDGE	Orientation of truss lumber such that the chord sheathing is applied to the least chord dimension and connector plates are embedded into the wider chord dimension.
LUMBER ON FLAT	Orientation of truss lumber such that chord sheathing is applied to the wider chord dimension and connector plates are embedded into the east chord dimension.
OVERHANG	The outward extension of one truss chord (usually the top chord), beyond the other chord (usually the bottom chord).
PANEL JOINT	The point of intersection where one or more webs meet the top or bottom chord.
PITCH BREAK	The point at which truss chord lumber changes slopes.
SCISSOR TRUSS	A type of truss having an inclined bottom chord.

SEASONED LUMBER	Lumber, which has been seasoned to approximately 15% moisture content to a depth of 20mm from the surface. For plating purposes, at the time of fabrication, seasoned lumber will be that which has moisture content of 19% or less as per CSA S347.
SLOPE	The ratio of vertical rise to horizontal run for inclined members.
SPLICE JOINT	The joint at which two chord members are joined together with truss connector plates to form a single member.
TOP CHORD	Horizontal or inclined lumber member that establishes the upper edge of a truss.
UNSEASONED LUMBER	Lumber of which the moisture content exceeds the requirements of seasoned lumber.
WEBS	Internal truss members that join the top and bottom chords to form triangular patterns that give truss action by carrying axial stresses.
WET SERVICE	Service conditions other than dry.

1.2 ABBREVIATIONS

ASTM	American Society for Testing and Materials
NFBCC 95	National Farm Building Code of Canada 1995
CCMC	Canadian Construction Materials Centre - National Research Council Canada, Institute for Research in Construction
CSA O86.1	CSA O86.1-94 Engineering Design in Wood (Limit States Design)
HSB	Housing and Small Buildings
LHO	Farm - Low Human Occupancy
NBCC95	National Building Code of Canada 1995
NBCC (ST.COMM.)	Structural Commentaries on the National building Code of Canada, 1995
NLGA	National Lumber Grades Authority
NRCC	National Research Council of Canada
TPIC	Truss Plate Institute of Canada

1.3 REFERENCE PUBLICATIONS

- ASTM A 653/A 653 M-94 "Specification for Steel Sheet, Zinc-Coated (Galvanized) or Zinc – Iron Alloy - Coated (Galvannealed) by the Hot-Dip Process."
- ASTM A 924/A 924 M-94 "Specification for General Requirements for Steel Sheet, Metallic – Coated by the Hot - Dip Process."
- CSA O86.1-94 Canadian Standards Association Publication "O86.1-94 Engineering Design in Wood (Limit States Design)"
- CSA S347 Canadian Standards Association Publication "S347-M1980 Method of Test for Evaluation of Truss Plates Used in Lumber Joints"
- NFBCC 1995 National Research Council of Canada Publication "National Farm Building Code of Canada 1995"
- NBCC 1995 National Research Council of Canada Publication "National Building Code of Canada 1995"
- NBCC (ST.COMM.) National Research Council of Canada Publication, "Structural Commentaries on the National Building Code of Canada 1995"

2. MATERIALS

2.1 Lumber Sizes and Grades

- 1) Net section properties shall be used for all truss designs.
- 2) Minimum nominal chord size for all trusses shall be 38 x 64 except for trusses used in mobile homes.
- 3) All trusses shall be manufactured using lumber graded by NLGA rules, with specified strengths as per CSA 086.1
- 4) All trusses shall be manufactured with No. 2 grade lumber or better for top and bottom chords.
- 5) All truss webs, except as those described in 2.1.6, shall be designed with any lumber grade provided the grade is listed and assigned a specified strength in CSA 086.1.
- 6) Truss webs of 38 x 64 lumber shall be No. 2 grade or better.

2.2 Steel

- 1) Truss Plates shall be manufactured from galvanized sheet steel conforming to or exceeding ASTM Standard A653/A653M-94 Standard specification for Sheet Steel, Zinc coated (Galvanized) by the Hot-Dip Process, Structural (Physical) Quality and shall have the following minimum properties.

Table 2.2(1) ASTM Specification A653/A653M-94 for Structural Quality Sheet Steel

GRADE (Old Designation)	230 (A)	255 (B)	275 (C)
Ultimate Tensile Strength, MPa	310	360	380
Minimum Yield, MPa	230	255	275
Elongation (at failure) in 50 mm length, %	20	18	16

Note: Alternatively, plates may be manufactured from appropriate type and grade high strength sheet steel conforming to specifications as per ASTM A653/A653M-94 HSLA. The ratio of tensile strength to yield point shall be not less than 1.2 and the total elongation shall not be less than 16% for a 50 mm gauge length.

- 2) Corrosion resistant coating shall conform to ASTM A924, "Standard Specification for Steel Sheet, Zinc-Coated (Galvanized) by the Hot-Dip Process, General Requirements", Coating Designation G90, or ASTM A924, "Standards Specification for Electrolytic Zinc-Coated Steel Sheets", Coating Class C, or such treatment as will give equivalent corrosion protection as applied to steel sheet before connector plates are stamped out. It is not necessary to re-coat connectors after stamping.
- 3) On metal connector plates there shall be provided some means such as holes, dimples, bosses, marked pattern, etc., to indicate location of any separately applied nails or fasteners so that nails or fasteners will not be spaced too closely together in the wood and cause excessive splitting. Plate Designer shall determine this nail or fastener minimum spacing. Blank metal plates without any type of indicated minimum spacing for nails or fasteners shall not be acceptable. The above applies only where supplementary fasteners are intended to augment the gripping value of plates.

TRUSS PLATE INSTITUTE OF CANADA (1996)

- 4) All plate manufacturers must have their plates listed in the Registry of Product Evaluations published by Canadian Construction Materials Centre, Institute for Research in Construction, Ottawa, Ontario.

3. SPECIFIED LOADS

3.1 Definitions

- D Specified dead load for the weight of the truss itself plus the weight of all materials of construction incorporated into the building to be supported permanently by the truss.
- L Specified live load due to intended use and occupancy; snow, ice and rain.
- W Specified live load due to wind.
- E Specified live load due to earthquake
- α Load factor, applied to a specified load which, for the limit state under consideration, takes into account the variability of the loads and load patterns and analysis of their effects.

The load factors for strength limit states design are as follows:

$$\alpha_D = 1.25$$

$$= 0.85 \text{ in cases of uplift or overturning}$$

$$\alpha_L = 1.50$$

$$\alpha_W = 1.50 \text{ for wind}$$

For serviceability limit states, all of the load factors are taken as 1.0

- χ Importance factor, applied to all factored loads other than dead load to take into account the consequences of collapse as related to the use and occupancy of the building.

$$\chi = 1.00$$

$$\chi = 0.80 \text{ for LHO farm trusses}$$

For serviceability limit states $\chi = 1.0$

- ψ Load combination factor, applied to factored loads other than dead loads to take into account the reduced probability of a number of loads from different sources acting simultaneously.

$$\psi = 1.0 \text{ when only one of L, W acts}$$

$$= 0.7 \text{ when L and W act together}$$

Factored load means the product of a specified load and its load factor.

$$\text{Factored dead load} = \alpha_D D$$

$$\text{Factored live load} = \alpha_L L$$

- 1) **Factored Load Combinations Not Including Earthquake.** For load combinations, not including earthquake, the factored load combination shall be taken as:

$$\alpha_D D + \gamma \psi [\alpha_L L + \alpha_W W]$$

- 2) **Factored Load Combinations Including Earthquake.** For load combinations including earthquake, the factored load combinations shall be taken as:

$$1.0D + \chi(1.0E); \text{ and either}$$

- a) For storage and assembly occupancies, $1.0D + \chi(1.0L + 1.0E)$; or

- b) For all other occupancies, $1.0D + \chi(0.5L + 1.0E)$

3.2 Specified Live Loads

3.2.1 Housing and Small Buildings (Part 9 of NBCC95)

- 1) Roof trusses meeting the housing and small building requirements of Part 9 of the NBCC95, with clear spans between bearings less than or equal to 12.19m, (40 feet) and a top chord slope $\geq 1/6$, shall be designed using a roof load not less than 60% of the appropriate ground snow load plus rain load as listed in the NBCC95 Appendix C.
- 2) Roof trusses meeting the housing and small building requirements of Part 9 of the NBCC95, with clear spans between bearings greater than 12.19m (40 feet) or a top chord slope $< 1/6$ shall be designed as per Section 3.2.2.
- 3) The minimum specified top chord live load shall be 1.0 kPa (21 psf)

3.2.2 Commercial Roof Trusses (Part 4 of NBCC95)

- 1) Commercial roof trusses shall be designed using a roof live load not less than 80% of the appropriate ground snow load plus rain load as listed in NBCC95 Appendix C, except where:
 - (a) Wind exposure conditions specified by Section 4.1.7 of NBCC95 are fulfilled, hence 60% of the ground snow load plus rain load may be used as the roof load, or
 - (b) The roof slope is greater than 30 degrees, hence the roof snow load can be reduced by a slope factor as specified by Section 4.1.7 of NBCC95, or
 - (c) The roof slope is greater than 15 degrees and slippery roof conditions specified by Section 4.1.7 of NBCC95 are fulfilled, hence the roof snow load can be reduced by a slope factor as specified in that Section, or
 - (d) The snow load is specified in writing by an authority having jurisdiction.
- 2) Commercial roof trusses shall be designed to meet the requirements of full and partial loading as specified by Section 4.1.6 and 4.1.7 or NBCC95.
- 3) Commercial roof trusses shall be designed to meet the requirements of unbalanced, sliding and drifting snow loads, as given in Section 4.1.7 of the NBCC95.
- 4) Commercial roof trusses with slopes of 15 degrees or less need not be designed for unbalanced snow loads.
- 5) The minimum specified top chord live load shall be 1.0 kPa. (21 psf)
- 6) The minimum specified live load for attics with limited accessibility shall be .5 kPa (10 psf) as per Table 4.1.6.3 NBCC95 unless specified otherwise by an authority having jurisdiction.
- 7) Commercial roof trusses shall be designed for wind loading in accordance with Section 4.1.8 NBCC95.
- 8) For wind analysis of commercial roof trusses the minimum reference velocity pressure shall be based on the probability of being exceeded once in 30 years for strength and once in 10 years for deflection. Appropriate wind loads are as listed in NBCC95 Appendix C.

3.2.3 Low Human Occupancy (Farm)

- 1) LHO roof trusses shall be designed using a roof live load not less than 80% of the appropriate ground snow load plus rain load as listed in NBCC95 Appendix C, except where:
 - (a) Wind exposure conditions specified by Section 4.1.7 of NBCC95 are fulfilled, hence 60% of the ground snow load plus rain load may be used as the roof load, or
 - (b) The roof slope is greater than 30 degrees, hence the roof snow load can be reduced by a slope factor as specified by Section 4.1.7 of NBCC95, or
 - (c) The roof slope is greater than 15 degrees and slippery roof conditions specified by Section 2.2.2.2 of NBCC95 are fulfilled, hence the roof snow load can be reduced by a slope factor as specified in that section, or
 - (d) The snow load is specified in writing by an authority having jurisdiction.
- 2) LHO roof trusses shall also be designed to meet the requirements of unbalanced, sliding and drifting snow loads as given in Section 4.1.7 of NBCC95.
- 3) LHO roof trusses referenced in 2.2.2.1 of the NBCC95 with slopes of 15 degrees or less need not be designed for unbalanced snow loads.
- 4) The minimum specified top chord live load shall be 1.0 kPa. (21 psf)
- 5) LHO roof trusses shall be designed for wind load in accordance to Section 4.1.8 of NBCC95.
- 6) For wind analysis of LHO roof trusses the minimum reference velocity pressure shall be based on the probability of being exceeded once in 10 years.

3.2.4 Residential Floor Trusses (Part 4 of NBCC95)

- 1) The minimum residential specified live load for bedrooms shall be 1.4 kPa. (30 psf)
- 2) The minimum residential specified live load for other than bedrooms shall be 1.9 kPa. (40 psf)
- 3) Floor trusses must be designed to satisfy the most critical loading conditions of full or partial loading.

3.2.5 Commercial Floor Trusses (Part 4 of NBCC95)

- 1) The minimum specified live load for commercial assembly areas that follow the guidelines given in Table 4.1.6.3 of NBCC95 shall be 2.4 kPa. (50 psf)
- 2) The minimum specified live load for commercial assembly areas and/or other areas that follow the guidelines given in Table 4.1.6.3 of NBCC95 shall be 4.8 kPa. (100 psf)
- 3) Floor trusses must be designed to satisfy the most critical loading conditions of full or partial loading.
- 4) The specified load due to possible concentrations of loads resulting from the use of area of floors, shall not be less than that listed in Table 4.1.6.10 of NBCC95 applied over an area of 750 mm (30 in) x 750 mm (30 in) located as to cause the maximum effect.

3.3 Specified Dead Loads

3.3.1 Roof Dead Loads

The following minimum dead loads specified in Table 3.3.1 shall be used for all designs unless specified by an authority having jurisdiction.

Table 3.3.1 Minimum Dead Loads, kPa (psf)

Occupancy	TC Dead Load		BC Dead Load	
	<1:6 (2/12)	≥1:6 (2/12)	With Ceiling	Without Ceiling
Residential (Part 9)	N/A	0.15 (3)	0.34 (7*)	N/A
Commercial (Part 4)	0.5 (10)	0.25 (5)	0.34 (7)	0.25 (5)
Farm (Part 4)	0.5 (10)	0.20 (4)	0.34 (7)	0.20 (4)

*This in combination with 3 psf BCLL for a total of 10 psf as per NBCC Section 9.4.2.4

3.3.2 Floor Dead Loads

- 1) The minimum dead loads specified below shall be used for all designs unless specified otherwise by an authority having jurisdiction.
- 2) The minimum top chord dead load shall be 0.5 kPa (10 psf)
- 3) The minimum bottom chord dead load shall be 0.25 kPa (5 psf)
- 4) In areas of a building where partitions, other than permanent partitions shown on design drawings, or, where partitions might be added in the future, allowance shall be made for the weight of such partitions.

The partition weight allowance for the above shall be determined from the actual or anticipated weight of the partitions placed in any probable position, but shall not be less than 1.0 kPa (20 psf) over the area of floor being considered.

- 5) A non-bearing partition wall may be neglected in the design provided:
 - a) Live load of supporting truss system results from residential occupancy and is not less than specified in 3.2.4.
 - (b) Floor trusses are not spaced over 610 mm o/c (24 in o/c)
 - (c) Top chord panel length of supporting truss system does not exceed 750 mm (30 in) for lumber-on-flat trusses.
 - (d) Partition weight does not exceed 0.88 kN/m (60 plf)
 - (e) Partition wall is not to be parallel to the trusses.

4. MEMBER DESIGN PROCEDURE

4.1 ANALOGUE

4.1.1 Analogue Joint Types

- (a) Pitch Break Joint: A joint formed by the intersection of two non-parallel chords (see Fig 4.1.2).
- (b) Heel Joint: A pitch break joint consisting of a non-vertical top chord and non-vertical bottom chord (see Fig 4.1.2).
- (c) Splice Joint: A joint formed by two parallel and adjacent chords (see Fig 4.1.2.3).
- (d) Lapped Joint: A joint formed by one end of a chord placed parallel and in contact with the adjacent chord along one of its edges (see Fig 4.1.2.4).
- (e) Web Joint: A joint formed by one or more webs along one edge of a given chord (see Fig 4.1.2.5).
- (f) Internal Joint: A joint formed by two web joints on opposite edges of a given chord such that their contact lengths overlap along the axis of the chord (see Fig 4.1.2.6).
- (g) Tail Bearing Joint: A joint consisting of a single member going to a support. (see Fig 4.1.2.7)
- (h) Top Chord Bearing Joint: A joint consisting of two or more members connecting at an exterior support. (see Fig 4.1.2.8)
- (i) Bearing Joint: A joint where a bearing touches a chord. (see Fig 4.1.2)

4.1.2 Analogue Points

- (a) Simple Analogue Point: An analogue point consisting of only one point formed by two uniquely identifiable lines.
- (b) Compound Analogue Point: Analogue formed by two or more joints located at the same physical joint. (see Fig 4.1.2)

Except as in 4.1.3, analogue points shall be constructed as described in this section.

4.1.2.1 Heel Analogue: The heel analogue is a compound analogue consisting of three simple analogue points and three fictitious members. (see Fig 4.1.2.1.A-G)

- a) First analogue point shall be determined as follows: Construct a vertical line at the end of TC or BC member whichever is shorter. (For Girder Heel, end of BC is always used to construct this line. See Fig 4.1.2.1.B) Find the intersection of the vertical line with the centrelines of the TC and BC. First heel analogue point shall be the lower of the two intersection points. This is the bearing point except as mentioned in (f) below.
- b) The second heel analogue point shall be located at the intersection of the centreline of BC and a vertical at 75% of scarf length from the first analogue point. This vertical may not be more than 610mm (24") away from the first analogue point.
- c) The third heel analogue point shall be located along the centreline of the top chord directly above the second heel analogue point.
- d) Where the second and the third points are closer to the first point than 2", remove the second and third points and reduce the heel analogue to simple analogue.
- e) In the case of a reinforcing member, a fourth point is required. The reinforcing member acts as the fourth member. The fourth point is the intersection of the centreline of the chord with a line perpendicular to the chord at a distance "d/2" where "d" is the depth of the chord. (see Fig 4.1.2.1.C & D)

- f) In the case of a reinforcing web, the analogue is similar to the reinforcing member analogue with the following exceptions:
1. The fourth analogue point is the analogue point of the adjacent joint.
 2. The fourth member is the reinforcing web.
 3. The bearing point is the first analogue point only if any part of the bearing surface falls between the first and second analogue points inclusive. (see Fig 4.1.2.1.C & E) Short cantilever and high heel rules apply. (see Appendix "A")
 4. If any part of the bearing surface falls past the second analogue point, the bearing point is at the second analogue point or a new bearing joint is introduced depending on the contact between the bearing surface and the scarf of the reinforcing web. (see Fig 4.1.2.1F) Short cantilever and high heel rules do not apply for this condition.
 5. If the reinforcing web is not fully parallel and touching the chord, two separate joints are constructed; a heel joint and a web joint. (see Fig 4.1.2.1G)

4.1.2.2 Pitch Break Analogue Point: The pitch break analogue point shall be located along a plumb line through the outside edge intersection of the two chords. The analogue point shall have the same X coordinate as the plumb location and Y coordinate equal to the average Y coordinates formed by intersection points of the chord centrelines and the plumb line. (see Fig 4.1.2.2)

In case of a mitre cut pitch break, the analogue point is the intersection of the centrelines of the chords. (see Fig 4.1.2.2.A) For corner joints, the analogue point shall be the intersection of the centreline of the chord and a line at the end of the chord. (see Fig 4.1.2.2.B)

4.1.2.3 Splice Joint Analogue Point: Analogue point shall be the point located at the halfway point between the intersection points of the centrelines of the two chord members and the splice line. (see Fig 4.1.2.3)

4.1.2.4 Lapped Joint Analogue Point: Analogue point shall be the point located at the halfway point between the intersection points formed by the end cut and centrelines of the chord members on the two sides of the joint. (see Fig 4.1.2.4)

4.1.2.5 Web Joint Analogue Point: Analogue point shall be the intersection of the centrelines of chord and a line perpendicular to the chord passing through the centre of contact area between the webs and the chord. (see Fig 4.1.2. and Fig 4.1.2.5)

4.1.2.6 Internal Joint Analogue Point: Analogue point shall be the intersection of the centreline of chord and a perpendicular through the centre of common contact area, from both sides, between the webs and the chord. (see Fig 4.1.2.6)

4.1.2.7 Tail Bearing Joint Analogue Point: Analogue point shall be at the intersection of the centreline of the chord and a vertical through outside corner of support. For a vertical tail bearing, use the horizontal through the outside corner of bearing instead of the vertical. (see Fig 4.1.2.7)

4.1.2.8 Top Chord Bearing Joint: Except as in 4.1.2.9 the top chord bearing joint analogue is compound and consists of two points. The first point is the bearing point and it is the intersection of the centreline of the top chord with a vertical through the centreline of the required bearing size based on the clear span. The second point is the intersection of the centreline of the top chord with a vertical through the inside edge of the bearing. (see Fig 4.1.2.8)

4.1.2.9 Top Chord Bearing Joint With End Vertical and Block: The analogue of this point is compound and consists of three points and two fictitious members. The first joint is the bearing point and it is the intersection of a vertical through centreline of the required bearing size and surface of bearing. The second point is the intersection of a horizontal through the first point and the outside edge of end vertical. The third point is intersection of the centreline of the top chord and the outside edge of end vertical. (see Fig 4.1.2.9)

Top chord bearing joint guidelines in section 4.6.6 must be observed when using the analogue described in the above sections (4.1.2.8 and 4.1.2.9)

4.1.3 Analogue Modifications

4.1.3.1 Analogue points shall be constructed using the following hierarchy: Pitch break joints, then, most member to least member web joints. All other joints not mentioned here may be constructed in any order.

4.1.3.2 Analogue points for joints connected by a vertical web to joints of higher hierarchy shall be obtained as intersection of vertical through the higher hierarchy joint and the centreline of chord.

4.1.3.3 Two analogue points closer to each other than 2" (unprojected) shall be reduced to one joint located between the two original joints.

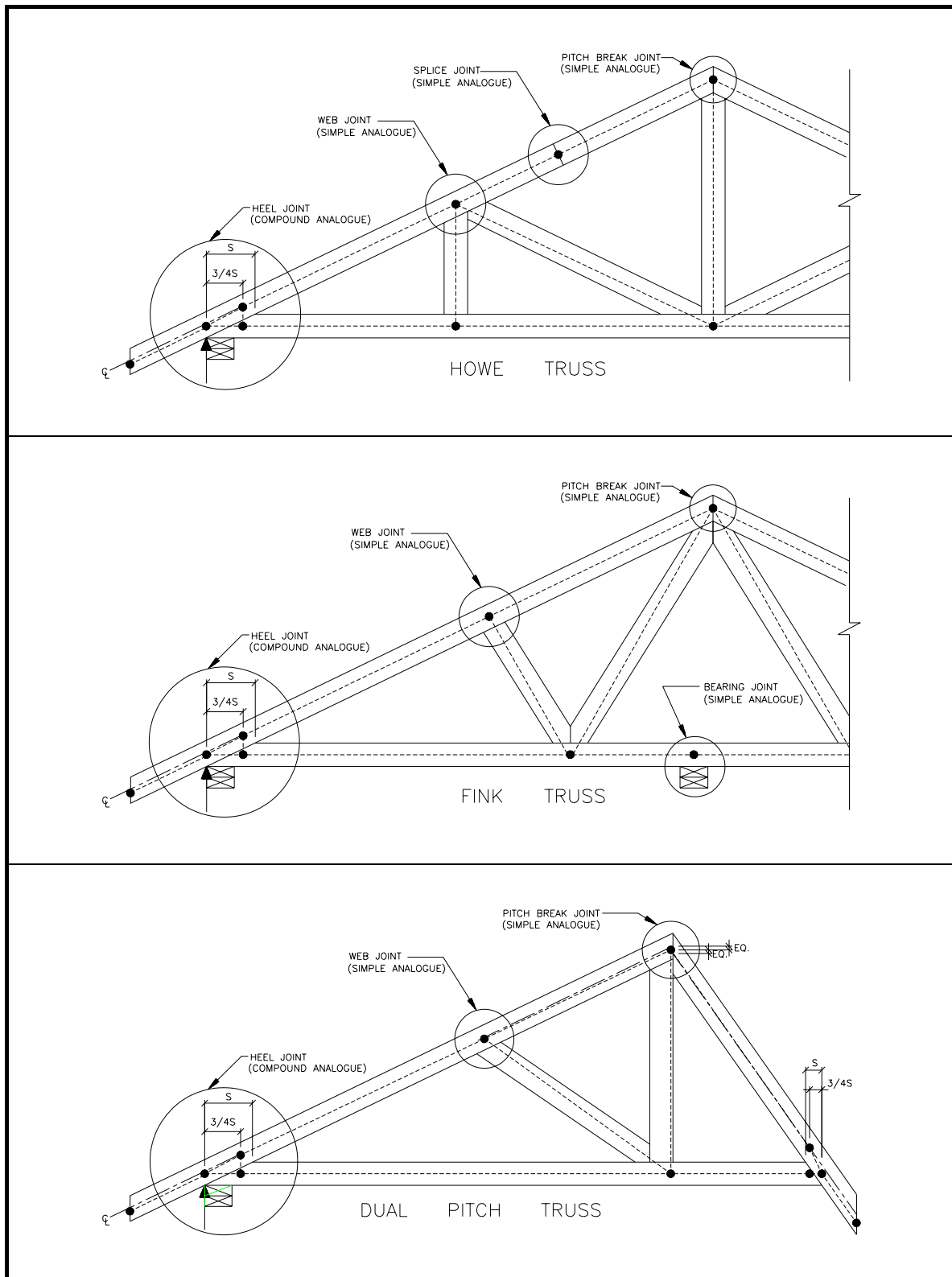

Figure 4.1.2 Simple and Compound Analogue

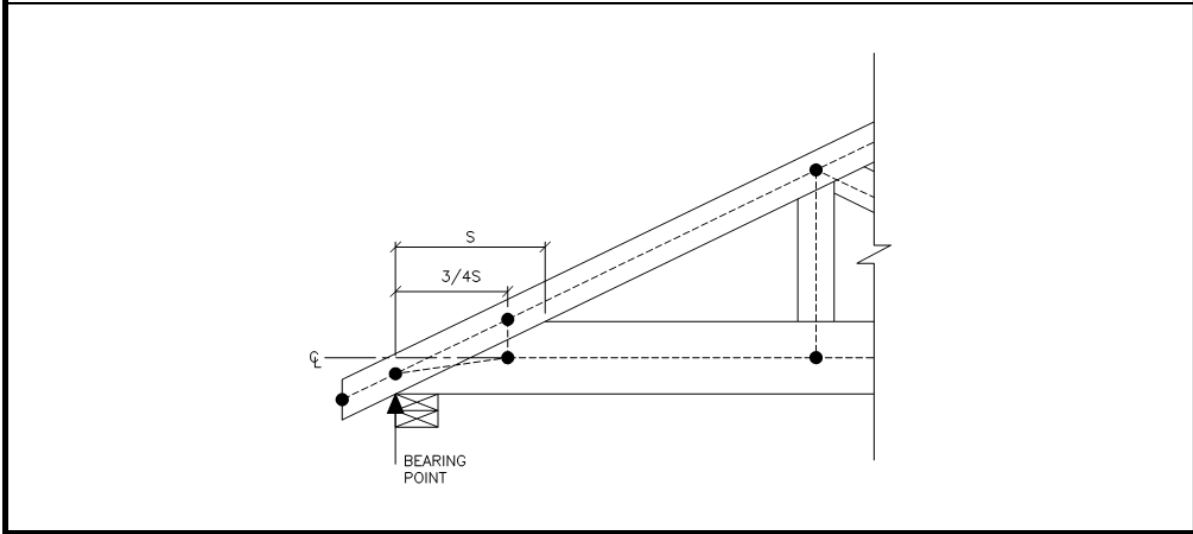
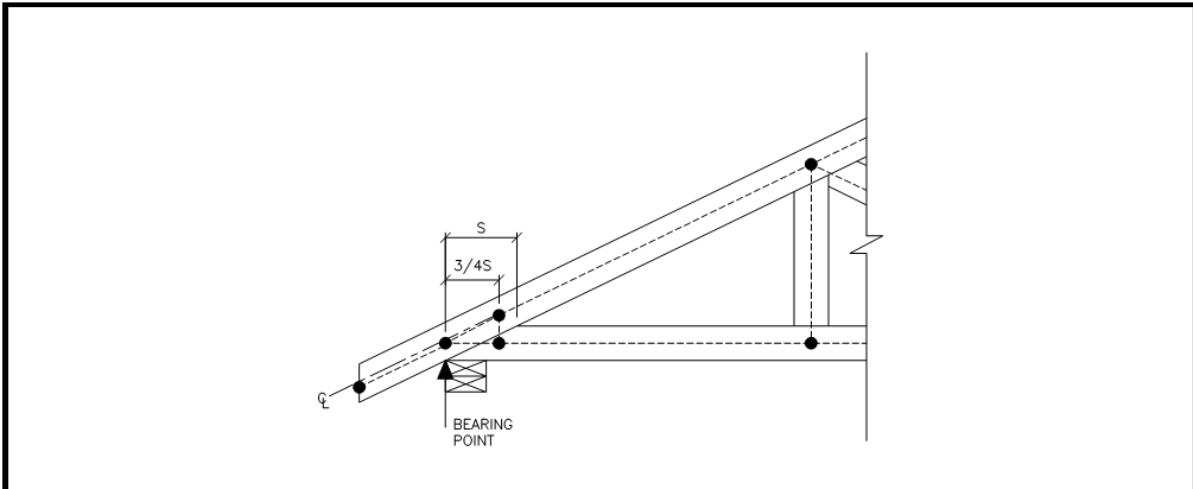

Figure 4.1.2.1.A Standard Heel Analogue

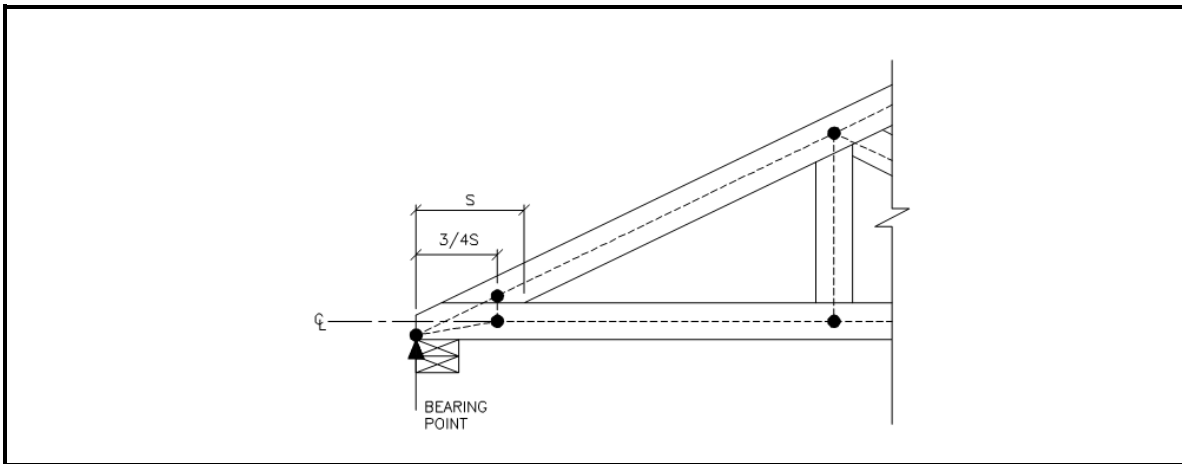

Figure 4.1.2.1.B Girder Heel

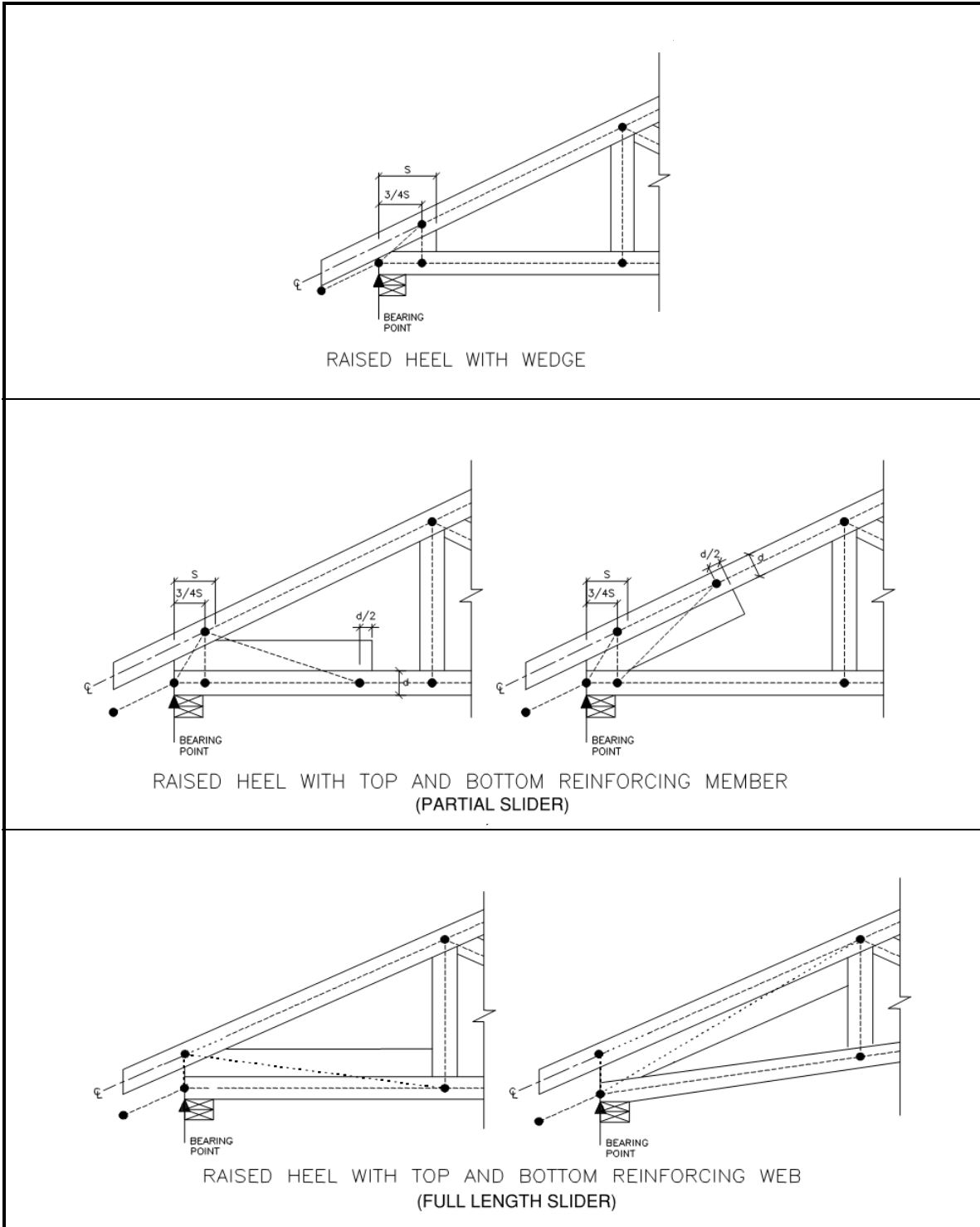

Figure 4.1.2.1.C Raised Heels

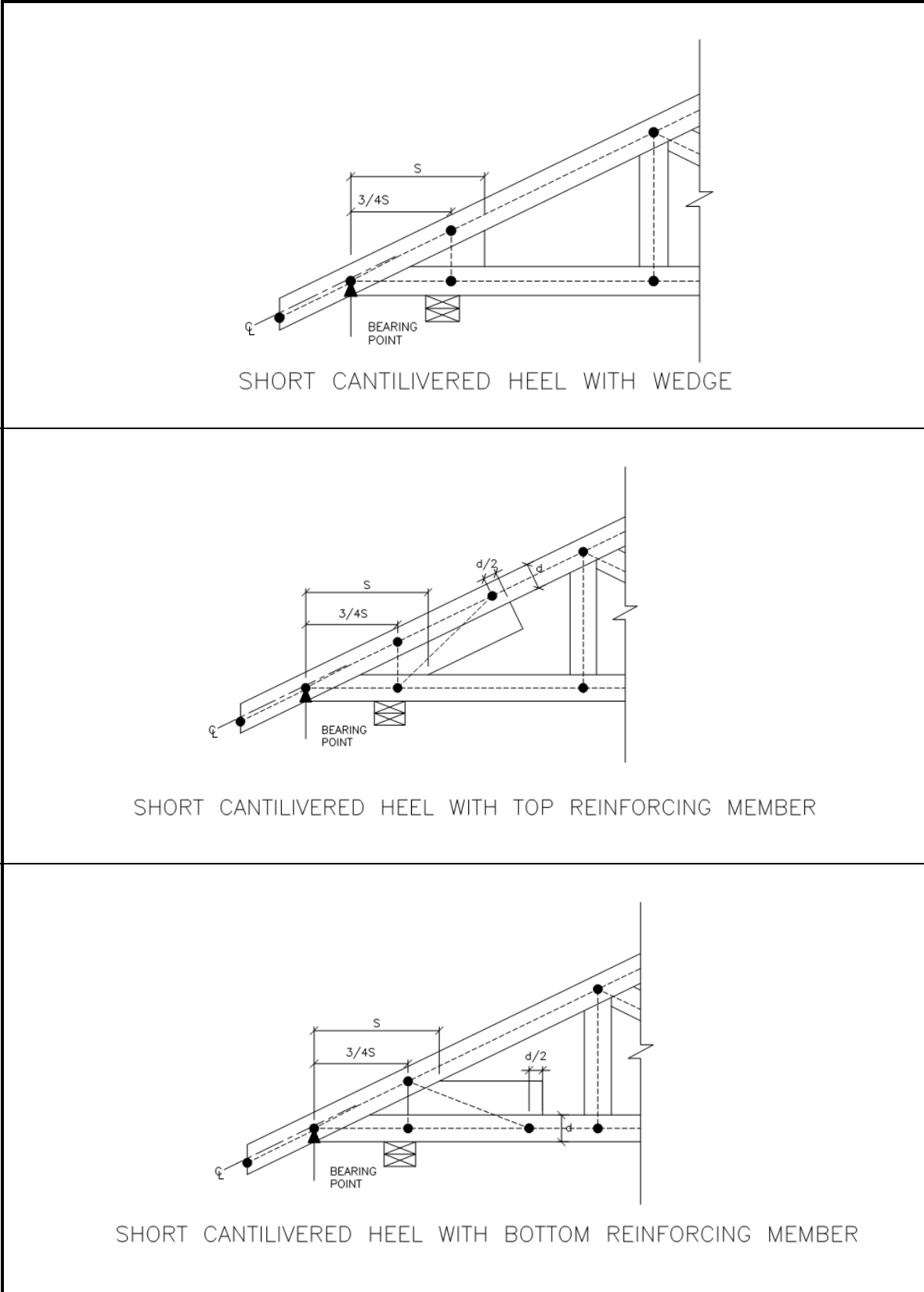
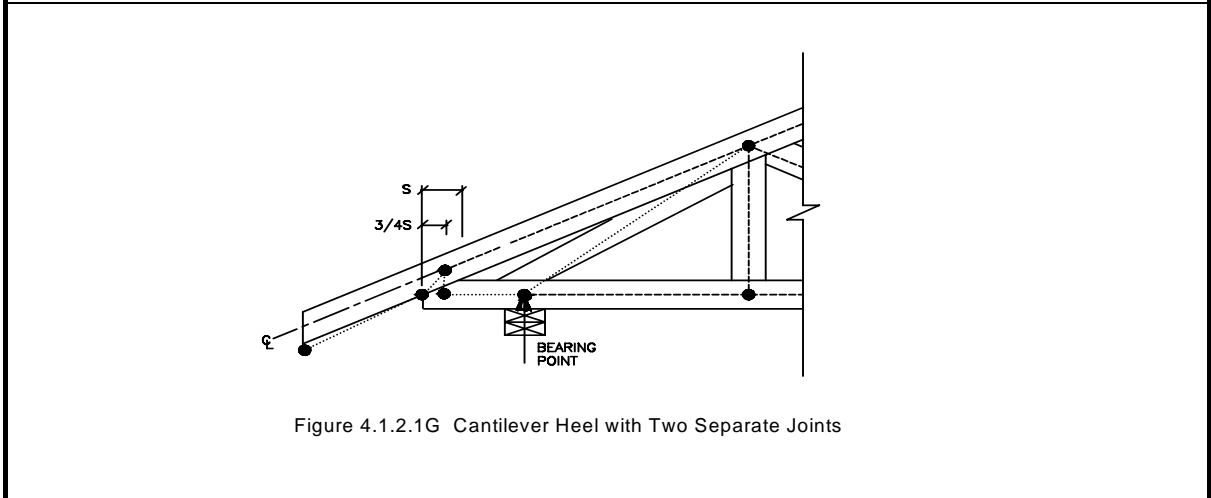
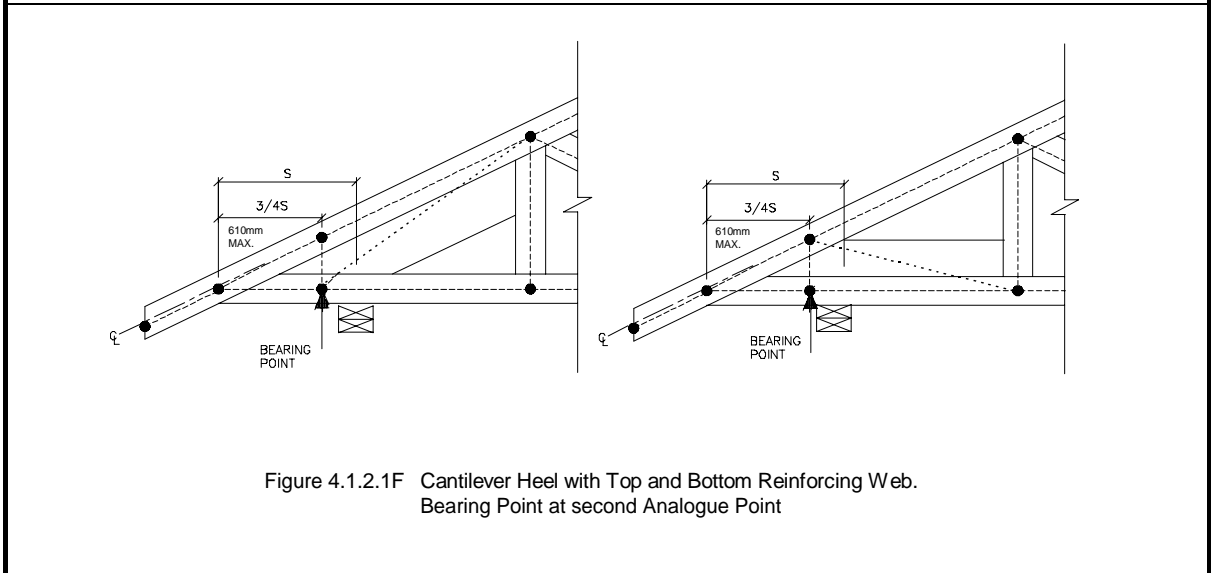
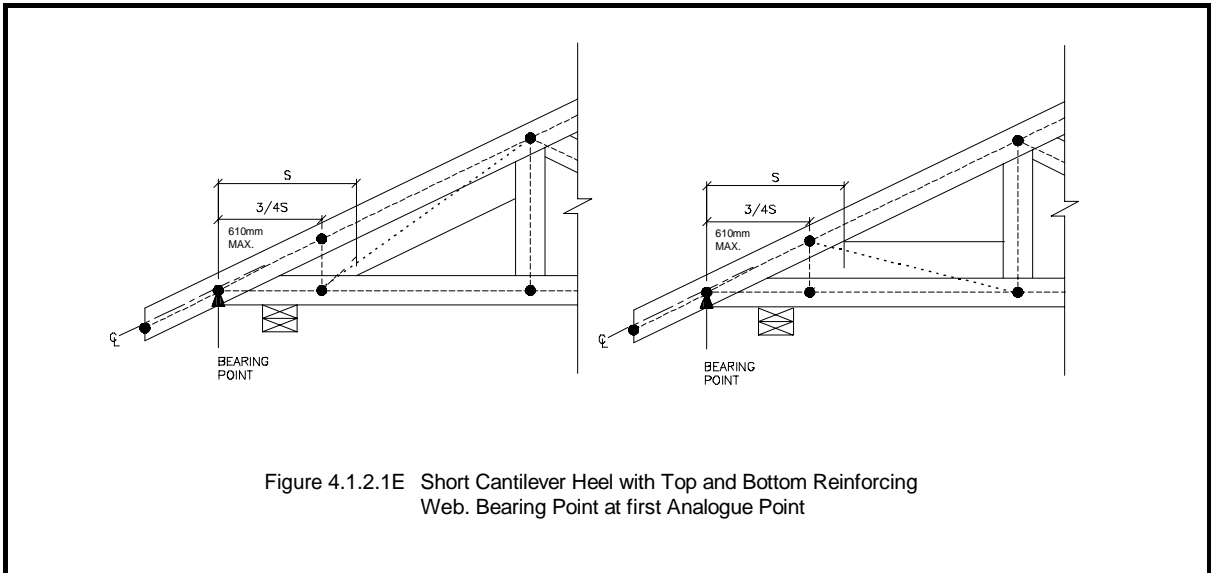

Figure 4.1.2.1.D Short Cantilevered Heels



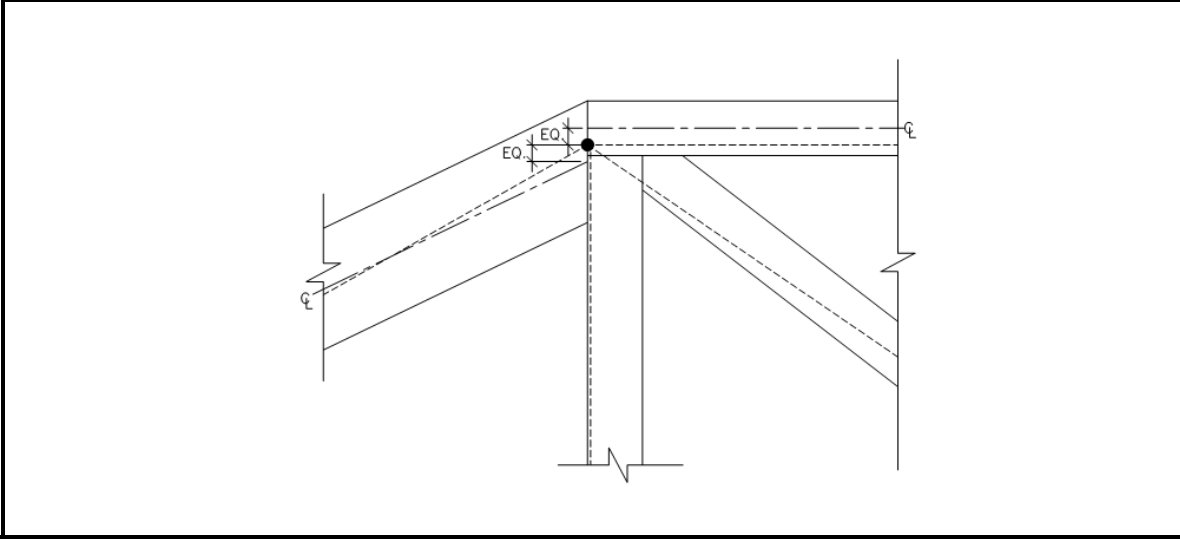

Figure 4.1.2.2 Pitch Break Joint

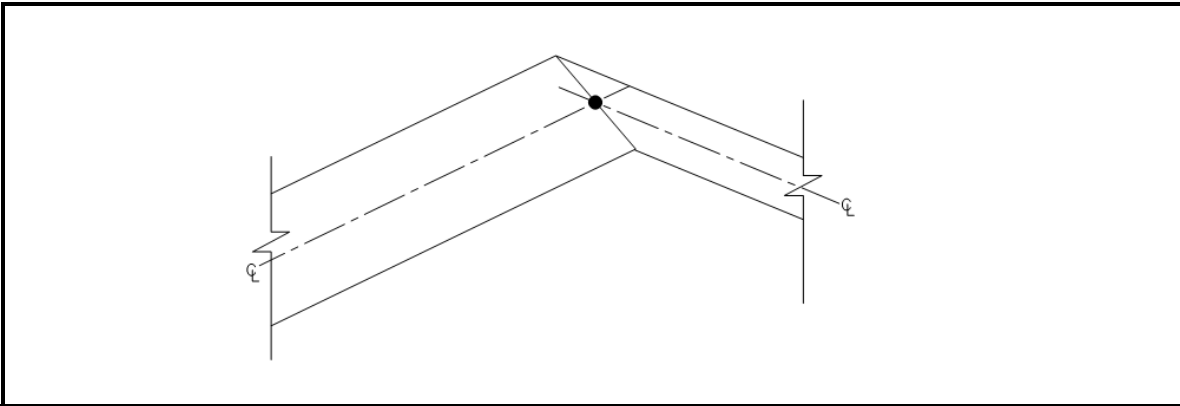

Figure 4.1.2.2.A Mitre Cut Pitch Break Joint

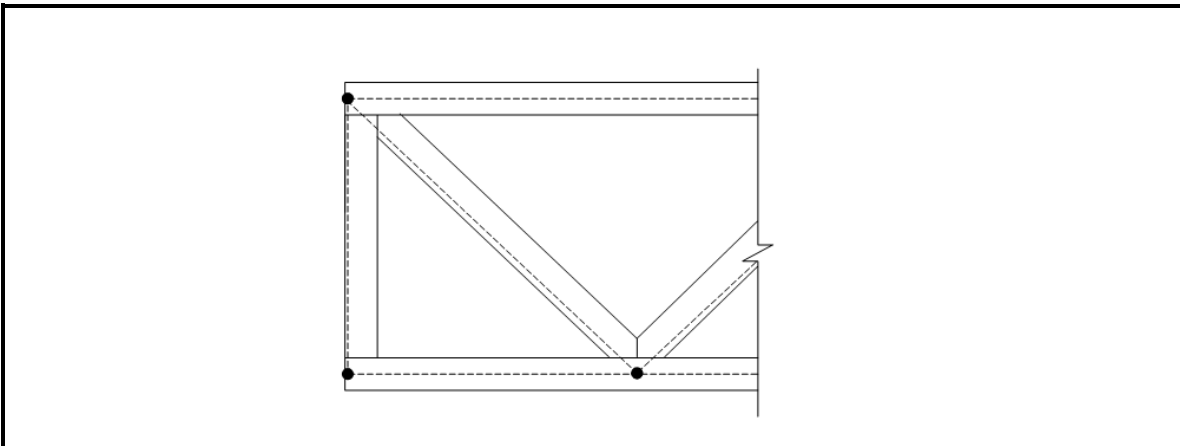

Figure 4.1.2.2.B Corner Joint

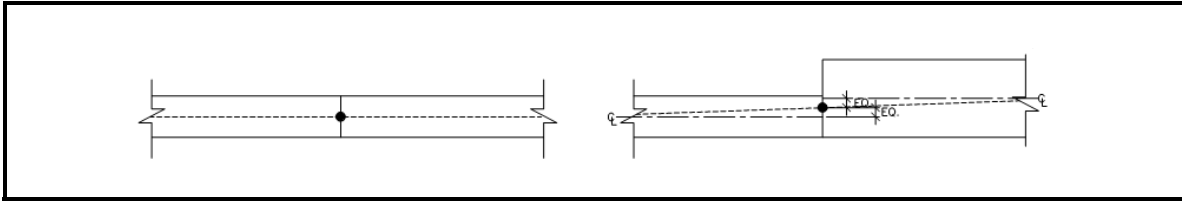

Figure 4.1.2.3 Splice Joint

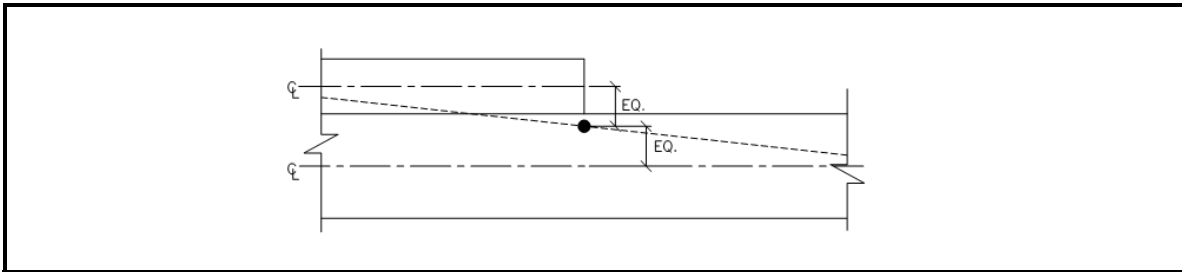

Figure 4.1.2.4 Lapped Joint

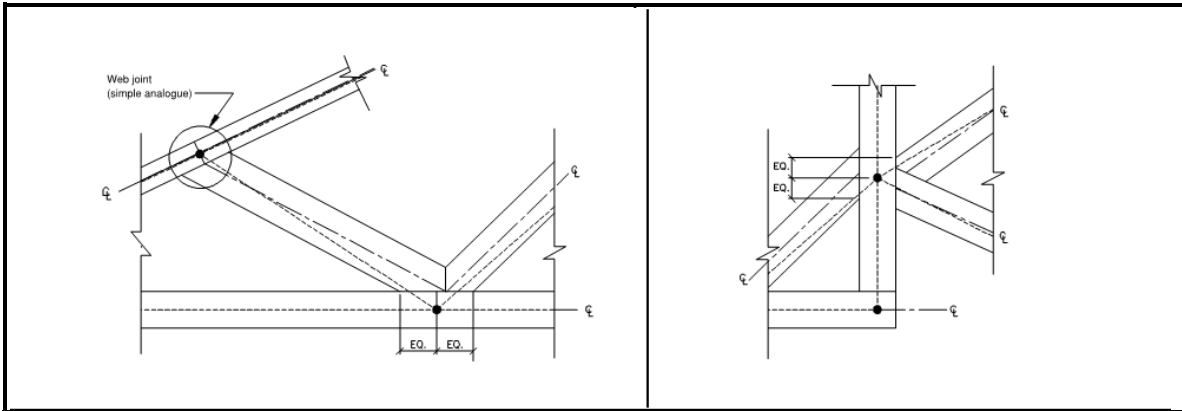

Figure 4.1.2.5 Web Joints

Figure 4.1.2.6 Internal Joint

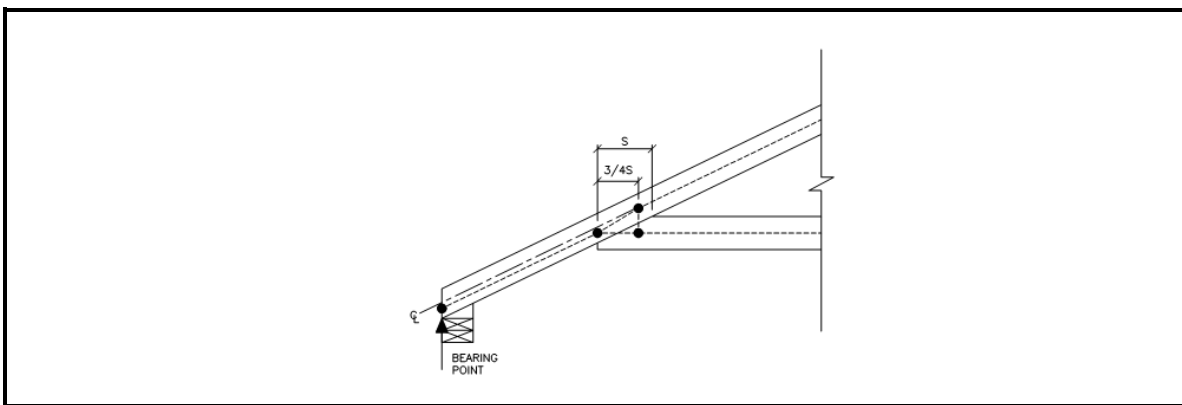

Figure 4.1.2.7 Tail Bearing Joint

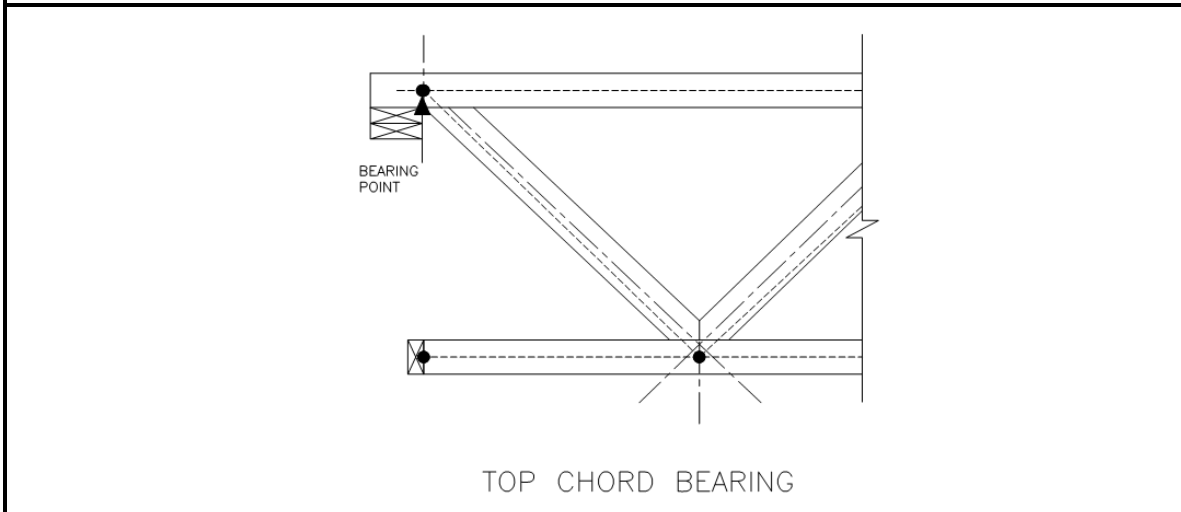
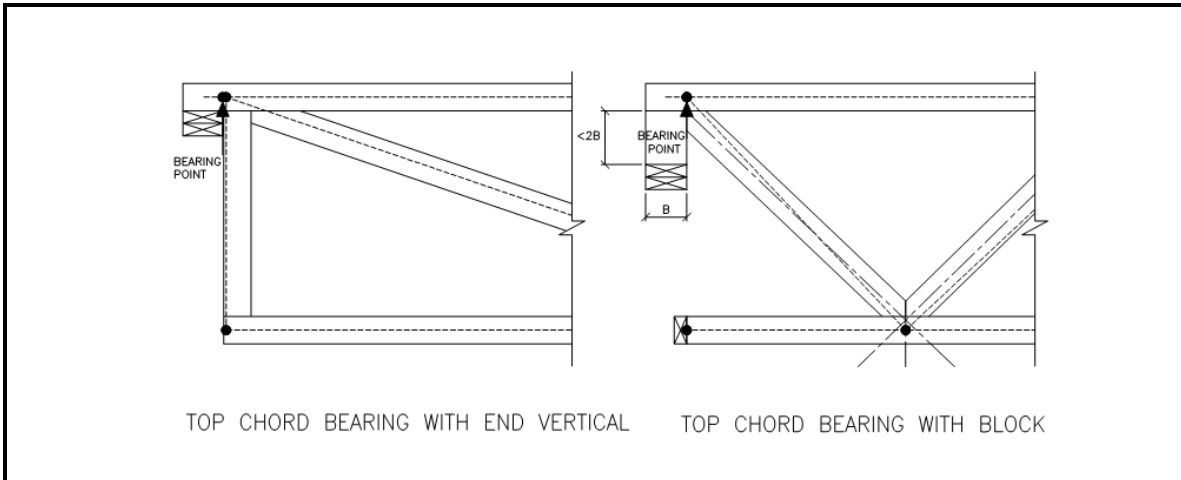

Figure 4.1.2.8 Top Chord Bearing Details

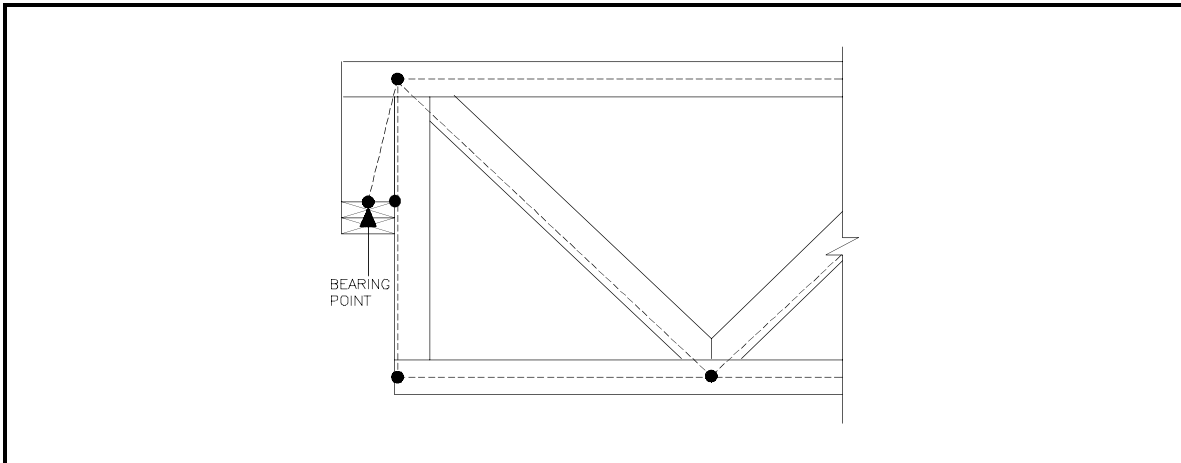

Figure 4.1.2.9 Top Chord Bearing with End Vertical and Block

4.2 Strength and Serviceability Limit States

4.2.1 Method of Analysis

Structural analysis shall be by stiffness or flexibility method utilizing pin-rigid mathematical model.

1) Truss Model

- (a) All chord members shall be rigidly connected through joints, including web joints and lapped joints. All splices shall be considered pinned unless designed for moment. Fictitious members representing top and bottom chords at the heel shall be pinned to each other but rigidly connected at other end.
- (b) Ends of members connecting to pitch break joints shall be considered pinned at the joints.
- (c) The fictitious vertical strut at heel shall be pinned to top and bottom chords.
- (d) Properties of fictitious members shall be as follows:
A top chord fictitious member shall have the same properties as the adjacent top chord.
A bottom chord fictitious member shall have the same properties as the adjacent bottom chord. Other fictitious members shall have the properties of 2x4 No.2 S.P.F. lumber.
- (e) Fictitious members in top chord bearing conditions such as in detail 4.1.2.9 shall be pinned at both ends and have properties of 2x4 No. 2 S.P.F. lumber.
- (f) Overhangs shall be modelled such that they impose zero moment to the adjacent top chord member.

2) Support Model

Except for the leftmost support, all supports shall be considered as horizontal or vertical rollers. The leftmost support must be pinned. No support shall be considered to provide rotational restraint unless such restraint is adequately specified on the drawing. At a heel joint the support shall be located at the first analog point (the outermost joint). Except at heel joints, a support is considered to be at a joint when there is an overlap between contact surfaces of bearing and webs. A support is considered to be at the heel joint if the heel condition is to be used with short cantilever rules. See Section 4.6.3

3) Member Forces and Moments

- (a) Member force shall be the average of the member end forces. Member force for connections shall be the actual member forces at the joint.
- (b) Panel moment shall be taken as the maximum moment within the panel. Panel point moment shall be that at each individual panel end.
- (c) Combined Stress index shall be calculated for the panel on the basis of CSI from average member force combined with the greater of maximum panel moment or the maximum panel point moment.

4.2.2 Strength Limit States

The design of truss members for strength limit states shall include:

- (a) Establish the value of the effect of the factored loads for the load combinations specified in Section 3; and
- (b) Confirmation by rational means that for each load effect in item (a), the structural effect falls within the limits specified in appropriate clauses contained herein.

4.3 Specified Strengths

4.3.1 Visually Stress-Graded Lumber

The specified strengths (MPa) for visually stress-graded structural joist and planks, light framing, structural light framing and stud grade categories of lumber shall be those presented in Table 5.3.1.A and Table 5.3.1.B of O86.1.

4.3.2 Machine Stress-Rated And Machine Evaluated Lumber

The specified strengths (MPa) for machine stress-rated lumber are given in Table 5.3.2 of O86.1. The specified strengths (MPa) for machine evaluated lumber are given in Table 5.3.3 of O86.1. The specified strengths in shear are not grade dependent and shall be taken from Table 5.3.1.A of O86-01 for the appropriate species.

4.3.3 Design Specified Strengths

The design specified strengths are the product of the basic specified strengths and the appropriate strength modification factors as in Section 4.3.4.

4.3.4 Modification Factors

The strength modification factors are defined as follows:

1) Load Duration Factor, K_D

The specified strengths and resistances shall be multiplied by a load duration factor, K_D , in accordance with table 4.3.4.(1)

Table 4.3.4.(1) Load Duration Factor, K_D

Duration of Load	K_D	Explanatory Notes
Short term	1.15	Short term loading means that condition of loading where the duration of the specified loads is not expected to last more than 7 days continuously or cumulatively throughout the life of the structure. Examples includes wind loads, earthquake loads, impact loads.
Standard term	1.00	Standard term means that condition of loading where the duration of specified loads exceeds that of short term loading, but is less than permanent loading. Examples include snow loads, occupancy loads, in combination with dead loads.
Permanent	0.65	Permanent duration means that condition of loading under which a member is subjected to more or less continuous specified load. Examples include continuous floor loads, equipment loads.

For Standard Term loads where the dead load is greater than the live load, the duration factor can be calculated as:

$$K_D = 1.0 - 0.50 \log \left\{ \frac{D}{L} \right\} \geq 0.65 \quad \text{where } L = \text{specified live load}$$

$$D = \text{specified dead load}$$

2) Service Condition Factor, K_s

The specified strengths for sawn lumber shall be multiplied by the service condition factor K_s as indicated in Table 4.3.4.(2)

Table 4.3.4.(2) Service Condition Factors, K_s

K_s	Property	Wet service	Dry Service
K_{Sb}	Bending at extreme fibre	0.84	1.0
K_{Sv}	Longitudinal shear	0.96	1.0
K_{Sc}	Compression parallel to grain	0.69	1.0
K_{Scp}	Compression perpendicular to grain	0.67	1.0
K_{St}	Tension parallel to grain	0.84	1.0
K_{SE}	Modulus of elasticity	0.94	1.0

3) Treatment Factor, K_T

When lumber is treated with preservatives and retardants, the specified strengths, including modulus of elasticity, shall be decreased by treatment factor K_T as given in Table 4.3.4.(3)

Table 4.3.4.(3) Treatment Factor K_T

Product	Dry service conditions	Wet service conditions
Untreated Lumber	1.00	1.00
Preservative Lumber *	1.00	1.00
Fire-retardant Treated Lumber	0.90	0.90

*Refers only to unincised lumber as incised lumber is not permitted in trusses.

4) System Factor, K_H

Specified strengths for sawn lumber members in a light frame truss system consisting of three or more essentially parallel members spaced not more than 610 mm apart and so arranged that they mutually support the applied load may be multiplied by the system factor given in Table 4.3.4.(4)

Table 4.3.4.(4) System Factor K_H

Symbol	Property	K_H
K_{Hb}	Bending	1.10
K_{Hv}	Longitudinal shear	1.10
K_{Hc}	Compression parallel to grain	1.10
K_{Hcp}	Compression perpendicular to grain	1.00
K_{Ht}	Tension parallel to grain	1.10
K_{HE}	Modulus of elasticity	1.00

Note: These system factor increases are also applicable when spacing does not exceed 1220 mm for low human occupancy applications and for all girders consisting of not less than 3 members.

5) Size Factor K_z

Size factors presented in Table 4.3.4.(5) shall be used to increase basic specified strength.

Table 4.3.4.(5) Size Factor, K_z For Visually Graded Lumber

Symbol	Description	Lumber Size (mm) 38 x						
		64	89	114	140	184	235	286
K_{zb}	Bending	1.7	1.7	1.5	1.4	1.2	1.1	1.0
K_{zv}	Longitudinal shear	1.7	1.7	1.5	1.4	1.2	1.1	1.0
K_{zc}	Compression parallel to grain	*	*	*	*	*	*	*
K_{zcp}	Compression perpendicular to grain	**	**	**	**	**	**	**
K_{zt}	Tension parallel to grain	1.5	1.5	1.4	1.3	1.2	1.1	1.0
K_{zE}	Modulus of elasticity	1.0	1.0	1.0	1.0	1.0	1.0	1.0

* See Section 4.4.3.3

** See Section 4.4.4.4

4.4 Strength And Resistance

4.4.1 Bending Moment Resistance

- 1) The factored bending moment resistance, M_r of sawn members shall be taken as:

$$M_r = \phi F_b S K_{Zb} K_L$$

where	ϕ	=	0.9
	F_b	=	$f_b (K_D K_{Hb} K_{Sb} K_T)$
	f_b	=	specified strength in bending, MPa (Tables 5.3.1 to 5.3.3 of CSA O86.1)
	S	=	section modulus, mm^3
	K_{Zb}	=	size factor in bending
	K_L	=	lateral stability factor (Clause 4.4.1.(2))

- 2) Lateral Stability Factor, K_L

The lateral factor K_L may be taken as unity when lateral support is provided at points of bearing to prevent lateral displacement and rotation, and the following additional support is provided:

MEMBER SIZE	SUPPORT CONDITION
38 x 64 (2x3) 38 x 89 (2x4) 38 x 114 (2x5) 38 x 140 (2x6)	No additional intermediate support is required.
38 x 184 (2x8)	The member is held in line by purlins.
38 x 235 (2x10)	The compressive edge is held in line by direct connection of sheathing or purlins spaced not more than 610 mm (24 in) apart.
38 x 286 (2x12)	The compressive edge is held in line by direct connection of sheathing or purlins spaced not more than 610 mm (24 in) apart and adequate bridging or blocking is installed at intervals not exceeding 2280 mm (90 in).

Note: Alternatively, K_L may be calculated in accordance with Clause 6.5.6.4 of CSA O86.1.

4.4.2 Shear Resistance

The factored shear resistance, V_r for sawn members shall be taken as:

$$V_r = \phi F_v \frac{2A_n}{3} K_{Zv}$$

where	ϕ	=	0.9
	F_v	=	$f_v K_D K_{Hv} K_{Sv} K_T$
	f_v	=	specified strength in shear, MPa (Tables 5.3.1A and 5.3.1B of CSA O86.1)
	K_{Zv}	=	size factor in shear
	A_n	=	net area of cross-section, mm^2

4.4.3 Compressive Resistance Parallel To Grain

1) Effective Length

Unless noted otherwise, the effective length $L_e = K_e L_p$ shall be used in determining the slenderness ratio of truss compression members.

where $K_e = 0.8$ for buckling between adjacent panel points in the truss

$K_e = 1.0$ for buckling between brace or purlin locations on the truss

L_p = actual length of member between adjacent analogue panel points, or; locations of braces or purlins restraining buckling (normally perpendicular to the plane of the truss). For design of truss webs the longest cutting length shall be used.

Other recommended effective length factors K_e for compression members can be found in Appendix A.5.5.6.1 of CSA O86.1.

2) Simple Compression Members - Constant Rectangular Cross-Section

The slenderness ratio C_c of simple compression members of constant rectangular section must not exceed 50 and shall be taken as the greater of:

$$C_c = \frac{\text{effective length associated with width}}{\text{member width}}$$

$$C_c = \frac{\text{effective length associated with depth}}{\text{member depth}}$$

Note: The slenderness ratio C_c of a simple tension member shall be limited to 80.

3) Factored Compressive Resistance Parallel To Grain

The factored compressive resistance parallel to grain, P_r shall be taken as:

$$P_r = \phi F_c A K_{Zc} K_C$$

where $\phi = 0.8$

$F_c = f_c (K_D K_{Hc} K_{Sc} K_T)$

f_c = specified strength in compression parallel to grain, MPa
(Tables 5.3.1 to 5.3.3 of CSA O86.1)

$K_{Zc} = 6.3(dL)^{-0.13} \leq 1.3$

where d = dimension in direction of buckling (depth or width), mm

L = length associated with member dimension, mm

Note: The member length L used to compute the factor K_{Zc} shall be the greater of the panel length or one-half the chord length between pitch breaks for chord design; and, shall be the longest cutting length or the analogue length for web design.

4) Slenderness Factor, K_C

The slenderness factor, K_C , shall be determined from:

$$K_C = \left\{ 1.0 + \frac{F_c K_{Zc} C_c^3}{35 E_{05} K_{SE} K_T} \right\}^{-1}$$

where $E_{05} = 0.82E$ for MSR lumber

$= 0.75E$ for MEL lumber

$=$ as specified in Tables 5.3.1A and 5.3.1B of CSA O86.1, for visually graded lumber

4.4.4 Compressive Resistance Perpendicular To Grain (Bearing Resistance)

1) Effect of All Applied Loads

The factored compressive resistance perpendicular to grain under the effect of all factored loads shall be taken as Q_r in the following formula:

$$Q_r = \phi F_{cp} A_b K_B K_{Zcp}$$

where $\phi = 0.8$

$F_{cp} = f_{cp}(K_D K_{Scp} K_T)$

f_{cp} = specified strength in compression perpendicular to grain, MPa
(Tables 5.3.1 to 5.3.3 of CSA O86.1)

A_b = bearing area, mm²

K_B = length of bearing factor, Clause 4.4.4.5

K_{Zcp} = size factor for bearing, Clause 4.4.4.4

Note: The requirements of 4.4.4.(1) may be met by providing adequate bearing reinforcement against the effects of concentrated bearing loads acting near a support. See Section 5.5.9

2) Effects Of Loads Applied Near A Support

The factored compressive resistance perpendicular to grain, under the effect of only those loads applied within a distance from the centre of the support equal to the depth of the member, shall be taken as Q'_r in the following formula:

$$Q'_r = (2/3) \phi F_{cp} A'_b K_B K_{Zcp}$$

where $\phi = 0.8$

$F_{cp} = f_{cp}(K_D K_{Scp} K_T)$

A'_b = average bearing area (Clause 4.4.4.(3))

3) Unequal Bearing Areas On Opposite Surfaces Of A Member

Where unequal bearing areas are used on opposite surfaces of a member, the average bearing area shall not exceed the following:

$$A'_b = b \left\{ \frac{L_{b1} + L_{b2}}{2} \right\}, \text{but } \leq 1.5b(L_{b1})$$

where L_{b1} = lesser bearing length, mm

L_{b2} = larger bearing width, mm

b = average bearing width (perpendicular to grain), mm

4) Size Factor For Bearing, K_{Zcp}

For lumber used on flat, as opposed to on edge, the compression perpendicular to grain may be multiplied by a size factor for bearing, K_{Zcp} in accordance with Table 4.4.4.(4)

Table 4.4.4.(4) Size Factor For Bearing, K_{ZCP}

Ratio of Member Width To Member Depth*	K_{ZCP}
1.0 or Less	1.00
2.0 or More	1.15

* Interpolation applies to intermediate ratios.

5) Length Of Bearing Factor, K_B

When lengths of bearing are less than 150 mm, specified strengths in compression perpendicular to grain may be multiplied by a length of bearing factor in accordance with Table 4.4.4.(5) provided that:

- (a) no part of the bearing area is less than 75 mm from the end of the members; and
- (b) bearing areas do not occur in positions of high bending stresses.

Table 4.4.4.(5) Length Of Bearing Factor, K_B

Bearing Length Measured Parallel To Grain (mm)	Modification Factor, K_B
12.5 and Less	1.75
25.0	1.38
38.0	1.25
50.0	1.19
75.0	1.13
100.0	1.10
150.0 or More	1.00

4.4.5 Tensile Resistance Parallel To Grain

The factored tensile resistance, T_r , parallel to grain shall be taken as:

$$T_r = \phi F_t A_n K_{Zt}$$

where $\phi = 0.9$

$F_t = f_t (K_D K_{Ht} K_{St} K_T)$

$f_t =$ specified strength parallel to grain, MPa (Tables 5.3.1 to 5.3.3 of CSA O86.1)

$A_n =$ net area of cross-section, mm^2

$K_{Zt} =$ size factor in tension

4.4.6 Stress Index due to Bending

Members subject to factored bending moment, M_f , shall be so proportioned that:

$$\frac{M_f}{M_r} \leq 1.0$$

4.4.7 Stress Index due to Shear

Members subject to factored shear load, V_f , shall be so proportioned that:

$$\frac{V_f}{V_r} \leq 1.0$$

4.4.8 Stress Index due to Compression (Parallel to Grain)

Members subject to factored compressive axial load, P_f , shall be so proportioned that;

$$\frac{P_f}{P_r} \leq 1.0$$

4.4.9 Stress Index due to Compression (Perpendicular to Grain)

Members subject to factored compressive bearing load, Q_f , shall be so proportioned that;

$$\frac{Q_f}{Q_r} \leq 1.0$$

4.4.10 Stress Index due to Tension

Members subject to factored tensile axial load, T_f , shall be so proportioned that:

$$\frac{T_f}{T_r} \leq 1.0$$

4.4.11 Combined Stress Index due to Tension and Bending

Members subject to both bending and axial tension shall be so proportioned that:

$$\frac{T_f}{T_r} + \frac{M_f}{M_r} \leq 1.0$$

4.4.12 Combined Stress Index due to Compression and Bending

Except as permitted in Section 4.4.13, members subject to both bending and axial compression shall be so proportioned that;

$$\frac{P_f}{P_r} + \frac{M_f}{M_r} \leq 1.0$$

4.4.13 Combined Stress Index due to Compression and Bending

(Modified formula as per Section 5.5.13.5 CSA Supplement No.1-97 to O86.1)

Provided;

- (a) the members form part of a fully triangulated, metal plate connected truss; and;
- (b) the spacing of the truss does not exceed 610 mm (24 in) or the truss does not support more than 610 mm (24 in) of uniform loading; and;
- (c) clear spans between bearings does not exceed 12.20 m (40 ft) and, the design span or overall length of the truss, not including overhangs, does not exceed 18.3 m (60 ft), and;
- (d) the top chord slope is not less than 1/6, which is meant to exclude flat roof trusses but not flat top trusses forming part of hip roof systems;

Note: This clause is not for use with girder, bow string, semi-circular, attic, flat roof, or floor trusses.

Members subject to both bending and axial compression shall be so proportioned that;

$$\left\{ \frac{P_f}{P_r} \right\}^2 + \frac{M_f}{K_M M_r} \leq 1.0$$

1) Bending Capacity Modification Factor, K_M

The bending capacity modification factor, K_M , shall be determined as shown in the following:

(a) Compression chord members continuous over one or more panel points, and where;

$$1.0 < \frac{M_1}{M_2} \leq 3.0$$

$$K_M = \left[1.31 + 0.12 \left\{ \frac{M_1}{M_2} \right\} \right] \left\{ \frac{L_p}{d} \right\}^{-1/6} \leq 1.3$$

(b) Compression chord members continuous over one or more panel points, and where;

$$-1.0 \leq \frac{M_1}{M_2} \leq 1.0$$

$$K_M = \left[2.20 - 0.53 \left\{ \frac{M_1}{M_2} \right\} - 0.64 \left\{ \frac{M_1}{M_2} \right\}^2 + 0.41 \left\{ \frac{M_1}{M_2} \right\}^3 \right] \left\{ \frac{L_p}{d} \right\}^{-1/6} \leq 1.3$$

(c) All other compression chord members

$$K_M = 1.67 \left\{ \frac{L_p}{d} \right\}^{-1/6} \leq 1.3$$

where L_p = actual length of the member between adjacent analogue panel points, mm
 d = depth of the member between adjacent analogue panel points, mm
 $*M_1$ = maximum bending moment between analogue panel points, N-mm
 M_2 = maximum of the two panel point bending moments, N-mm

Note: The sign of the bending moment, M_1 and M_2 are retained in determining K_M . The factored bending moment, M_f , used in Section 4.4.13 is the larger of the absolute value of M_1 and M_2 .

* Maximum of bending moment at points along a panel where the slope of the moment curve changes sign. Where there are no such points along the panel, M_1 shall take the value of the bending moment at mid panel.

4.5 Serviceability Limit States

Design for serviceability Limit States shall include:

- (a) establishing the value of the effect of the specified loads for the load combinations specified in Section 3; and
- (b) confirming by rational means that for each load effect in item (a), the structural effect falls within the limits specified in appropriate clauses contained herein.

4.5.1 Serviceability Requirements (Allowable Deflections)

- 1) Modulus of Elasticity

The modulus of elasticity for stiffness calculations, E_s , shall be taken as:

$$E_s = E(K_{SE}K_T)$$

where

- E = specified modulus of elasticity
- K_{SE} = service condition factor
- K_T = treatment factor

- 2) Joint and member deflections shall be determined using the methods presented in Section 4.2.1. Loadings used are as described in Section 3.0.
- 3) Maximum vertical truss deflection shall be the largest of deflections calculated at any panel point, or within any bottom chord panel. Top chord members shall be checked for their vertical panel deflections relative to their end points.
- 4) Maximum truss deflection and loadings to be considered in computing these deflections are as shown in Table 4.5.1.(4). Lengths to be used in the limit ratios are shown in Figure 4.5.1.(4)

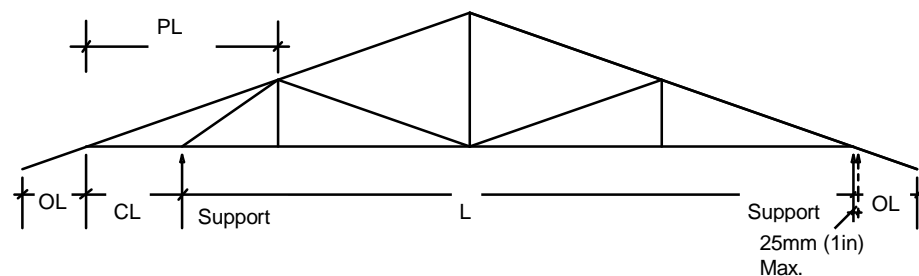

Figure 4.5.1.(4) Truss Deflection Lengths

Table 4.5.1.(4) Truss Deflection Limitations

Deflection Location	Application			
	Residential	Commercial	Farm	Floor
	Loading Used			
	1.33SL+0.5LL+DL	VL+DL	VL+DL	VL+DL
Allowable Deflection Limits - Vertical				
Top chord panel *	PL/180	PL/180	PL/180	PL/180
Bottom chord panel *	PL/240	PL/360	PL/240	PL/360
Cantilever	CL/120	CL/120	CL/120	CL/120
Overhang	OL/120	OL/120	OL/120	N/A
Bottom Chord Truss Joint or Panel	See Below	L/180 L/360 (DL)	L/180 L/360 (DL)	L/180 L/360 (DL)
(a) Plaster/Gypsum ceiling	L/360	L/360 (VL)	L/360 (VL)	L/360 (VL)
(b) Other ceiling	L/240	L/240 (VL)	L/240 (VL)	L/360 (VL)
(c) No ceiling	L/180	L/240 (VL)	L/240 (VL)	L/360 (VL)
Allowable Deflection Limit - Horizontal				
At Roller Support	25 mm (1 in)	25 mm (1 in)	25 mm (1 in)	25 mm (1 in)

Note: 1. (LL) refers to Live Load contribution only. (DL) refers to Dead Load contribution only.
2. Top and bottom panel deflection is local deflection measured relative to panel ends.

4.5.2 Permanent Deformation

Structural members supporting continuously applied loads in excess of 50% of the total specified load shall be designed to avoid excessive permanent deformation. An upper limit of 1/360 of the span should be imposed on the deflection due to continuously applied loads.

4.5.3 Ponding

The roof surface has to be provided with sufficient slope to allow drainage to prevent accumulation of rain water.

4.6 Special Design Considerations

4.6.1 Overhangs

Top chord overhangs for all categories of trusses shall be treated as simple overhangs, with no consideration of any support provided by the soffit return, except in cases where the truss designer is able to ensure that such consideration is provided for in the design and construction of the building.

4.6.2 Splices

Splice locations as permitted in section 4.6.2.(1) and 4.6.2.(2) with tolerances described in 4.6.2.(3) are only intended for use in trusses where these locations are of low chord moment. i.e. Chords of triangulated, uniformly loaded, statically determinate trusses. For other cases where the splice is positioned at a location of substantial chord moment, it must either be designed for in the connection, or, eliminated by describing the splice as a pin joint in the analysis.

1) Top Chord Splices

- (a) shall not be located at any joint and shall not be located in the panel adjacent to heel joint.
- (b) shall not be located at the quarter point adjacent to any perimeter break.
- (c) may be located at either quarter point of interior panels except there shall be no more than one splice per panel.

2) Bottom Chord Splices

- (a) shall not be located in the panel adjacent to heel joint and shall not be located at the quarter point adjacent to any perimeter break.
- (b) may be located between quarter points of interior panels.
- (c) may be located at any interior joint except that the joint adjacent to heel joint may not be spliced. Kingpost and Queenpost trusses may be spliced at the bottom chord interior joint. See Figure 4.6.2.(2) for referenced truss configurations.

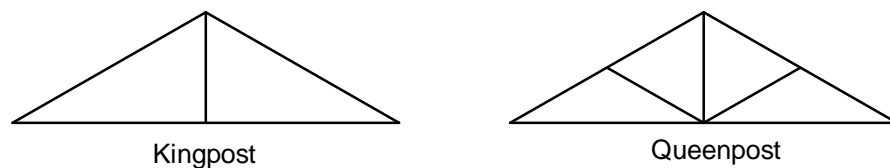

Figure 4.6.2.(2) Kingpost and Queenpost Truss Configurations

3) Maximum Tolerance in Splice Location

Maximum tolerance in splice location shall be $\pm 10\%$ of panel length.

4.6.3 Short Cantilevers and Heel Cuts

Short cantilevers and high heel cuts shall be designed in accordance to procedures presented in Appendix A.

4.6.4 Girder Trusses (Single and Multi-Ply)

- 1) Girder type heels are created by cutting the top chord onto a scarfed bottom chord. In this scarfing, the resulting section of bottom chord directly over the inside face of the bearing shall not be less than the greater of 50% of the original bottom chord section or 100 mm (4"). Girder type heel design procedures are presented in Appendix F.
- 2) Truss-to-truss connection of multi-ply girder trusses carrying load that is not evenly distributed to each ply shall be performed in accordance to Table B.1 to B.5, Appendix B. Girders carrying this type of loading shall be limited to 5 plies maximum.
- 3) Truss-to-truss connection of multi-ply girder trusses, carrying load that is evenly distributed to all plies, shall be performed using the minimum number of rows shown in Table B.1., Appendix B and a spacing of 300 mm (12 in). Girders carrying this type of loading shall be limited to 10 plies.

4.6.5 Truss Bracing

- 1) For instructions on installation of temporary and permanent truss bracing, refer to TPIC Brochure "Handling, Erection and Bracing of Wood Trusses".
Truss bracing location, as required in the design of the truss component, shall be specified by the truss designer/engineer.
- 2) For HSB trusses, minimum fastening of braces shall be as per NBCC95, Section 9.23.13.11
19 x 89 (1x4) braces 2 - 63 mm (2-1/2") common wire nails
38 x 89 (2x4) braces 2 - 76 mm (3") common wire nails.
- 3) An alternate method for bracing compression webs and long tension webs is by applying a member parallel to the web to form a T-section. See Table C.1.1, Appendix C.

4.6.6 Top Chord Bearing Guidelines

- 1) For lumber-on-edge top chord bearing trusses the recommended maximum factored reactions for Spruce-Pine-Fir and D.Fir chords are as shown in Table D.4.6.6.1, Appendix D for the various truss configurations. The recommended maximum gaps and minimum chord coverage must be observed when using these values.
Reaction limits are based on gross reaction and load duration factor for standard term loading. Values shall be adjusted downward for permanent loading and upward for short term loading using appropriate duration of load factors for plating.
- 2) For lumber-on-flat top chord bearing trusses, the recommended maximum factored reactions for Spruce-Pine-Fir and D.Fir chords are as shown in Table D.4.6.6.2 Appendix D for the various truss configurations. The recommended maximum gaps and minimum chord bites also shown must be observed when using these values.
Reaction limits are based on gross reaction and load duration factor for standard term loading. Values shall be adjusted downward for permanent loading and upward for short term loading using appropriate duration of load factors for plating.

5. JOINT DESIGN PROCEDURES

5.1 General

The design requirements for truss plate joints, utilizing light gauge metal plates, shall be in accordance with CSA-086.1 Section 10.

1) These procedures do not apply to the following conditions:

- (a) corrosive conditions
- (b) galvanized truss plates used in lumber that has been treated with fire retardant and is used in wet service conditions or in locations prone to condensation

NOTE:

For metal connector plates used in environmental conditions that fall within the scope of (a) & (b) above, refer to Appendix E.

2) Design criteria for truss plates are based on the following conditions:

- (a) the plate is prevented from deforming during installation;
- (b) the teeth are normal to the surface of the lumber;
- (c) the tooth penetration in joints is not less than that used in the tests to determine the resistance values; and
- (d) the lumber beneath the plate does not contain wane, loose knots, or knot holes

3) Thickness of members used in joints shall not be less than twice the tooth penetration.

4) Joint design shall be based on tight fitted joints with truss plates placed on opposing faces in such a way that, at each joint, the plates on opposing faces are identical and are placed directly opposite each other.

5) The lateral resistance value used to determine necessary plate area for any member shall be the appropriate value considering direction of load relative to grain and direction of load relative to primary axis of plate (see fig. 5.1.(5)). The resistance value is determined using the test values in conjunction with the formulae contained in Clause 5.3.3.

6) The unit values of lateral resistance of teeth shall be expressed as per tooth, per rosette, or per net area, whichever is appropriate or preferred. The design shall be based on net area method using test values or on gross area method using 80 percent of the test values and with areas defined in items (a) and (b) as follows:

- (a) the gross area is defined as the total area of member covered by a truss plate:
- (b) the net area is defined as the total area of a member covered by a truss plate less the area within a given distance from the edge or end of member. For net area calculation, the minimum end distance measured parallel to grain, shall be the greater of 12 mm (1/2"), or 1/2 the length of tooth; the minimum edge distance measured perpendicular to grain, shall be the greater of 6 mm (1/4"), or 1/4 the length of the tooth.

Any joint in a truss may be designed by either net or gross area method of joint design but not a combination of both within same joint.

7) Minimum Bite for Chords and Webs

At all joints, the connector plates are to be sized such that the minimum bites into all chords and webs are as given in Table 5.1.(7):

Table 5.1.(7) Minimum Bite For Chords and Webs, mm (in)

Truss Length L, m (ft)				
Lumber Size	0 < L ≤ 12.5 (0 < L ≤ 41)	12.5 < L ≤ 18.3 (41 < L ≤ 60)	18.3 < L ≤ 24.4 (60 < L ≤ 80)	24.4 < L ≤ 30.5 (80 < L ≤ 100)
38x64 (2x3)	38 (1.5)	45 (1.75)	n/a	n/a
38x89 (2x4)	38 (1.5)	45 (1.75)	51 (2.0)	57 (2.25)
38x114 (2x5)	38 (1.5)	45 (1.75)	51 (2.0)	57 (2.25)
38x140 (2x6)	38 (1.5)	51 (2.0)	57 (2.25)	64 (2.5)
38x184 (2x8)	51 (2.0)	57 (2.25)	64 (2.5)	76 (3.0)
38x235 (2x10)	64 (2.5)	70 (2.75)	76 (3.0)	83 (3.25)
38x286 (2x12)	76 (3.0)	76 (3.0)	83 (3.25)	89 (3.5)

- Note: (1) Plates must be sized so that the min. bite into chords is as shown above:
- parallel to chord direction
 - perpendicular to chord direction
- (2) Plates must be sized so that the min. bite into webs is as shown above:
- parallel to chord direction
 - perpendicular to chord direction
 - along the centreline of the web

- 8) Measurement and display of plate offsets shall be in 6 mm (1/4") increments, unless the plate placement can be otherwise described uniquely.

5.2 Connector Plate Evaluation

- The metal connector plate design values (per tooth, nail, square mm, linear mm, or other unit) shall be determined in accordance to procedures contained in CSA-S347 "Method of Test for Evaluation of Truss Plates used in Lumber Joints" latest edition.
- The tensile and shear values, for connector plates manufactured from a grade of steel higher than that used in the plate testing program, may be adjusted by the ratio of the ultimate tensile strength of the steel used in the manufacturing of the plate to that of the steel used in the test plates. This adjustment does not apply to the gripping values; these values may require adjustment, so should be verified by test.
- Strength resistance values for plates and teeth are to be obtained from tests carried out in accordance with CSA Standard S347, where the resistance values are
 - the average, divided by 1.6, of the 3 lowest of 10 ultimate test values for lateral resistance of the teeth;
 - the average of the 2 lowest of 3 corrected test values for tensile strength of the plate; and
 - the average of the 2 lowest of 3 corrected test values for shear strength of the plate at the angles specified;
- Lateral slip resistance values are to be obtained from tests carried out in accordance with CSA Standard S347, where the resistance values are the average of 10 test loads at 0.8 mm wood-to-wood slip divided by 1.4.

5.3 Strength Limit States

5.3.1 General

Truss plate joints shall be designed such that for the strength limit state, the effect of factored load is less than or equal to;

- (a) the factored ultimate lateral resistance of the teeth;
- (b) the factored tensile resistance of the plates; and
- (c) the factored shear resistance of the plates;

5.3.2 Modification Factors

- 1) Load Duration Factor, K_D

The load duration factor K_D for truss plates is as previously given in Table 4.3.4.(1)

- 2) Service Condition Factor, K_{SF}

The service condition factor, K_{SF} , for truss plates is given in Table 5.3.2.(2)

Table 5.3.2.(2) Service Condition Factor, K_{SF}

LUMBER CONDITION AT TIME OF MANUFACTURE			
Seasoned (Moisture Content 15%)		Unseasoned (Moisture Content > 15%)	
LUMBER CONDITION IN SERVICE			
DRY	WET	DRY	WET
1.00	0.67	0.80	0.67

- 3) Treatment Factor, K_T

The fire-retardment treatment factor, K_T , for truss plates is given in Table 5.3.2.(3)

Table 5.3.2.(3) Fire Retardant Treatment Factor, K_T

Not Seasoned after Treatment	Seasoned after Treatment
0.80	0.90

5.3.3 Ultimate Lateral Resistance

The ultimate lateral resistance of the teeth, n_u , are calculated as follows:

- (a) For loads parallel to the primary axis of the plate

$$n_u = \frac{p_u q_u}{p_u \sin^2 \theta + q_u \cos^2 \theta}$$

and

- (b) For loads perpendicular to the primary axis of the plate

$$n'_u = \frac{p'_u q'_u}{p'_u \sin^2 \rho + q'_u \cos^2 \rho}$$

where p_u , q_u , p'_u , q'_u are the ultimate lateral resistances obtained in accordance with Clause 5.2.(3) (a) used with the following values of θ and ρ :

$$p_u: \quad \theta = 0^\circ, \rho = 0^\circ$$

$$q_u: \quad \theta = 90^\circ, \rho = 0^\circ$$

$$p'_u: \quad \theta = 0^\circ, \rho = 90^\circ$$

$$q'_u: \quad \theta = 90^\circ, \rho = 90^\circ$$

where θ and ρ are defined in Figure 5.1(5)

When the primary axis of the plate is oriented at an angle other than parallel or perpendicular to the direction of the load, the resistance value shall be determined by linear interpolation between the values n_u and n'_u .

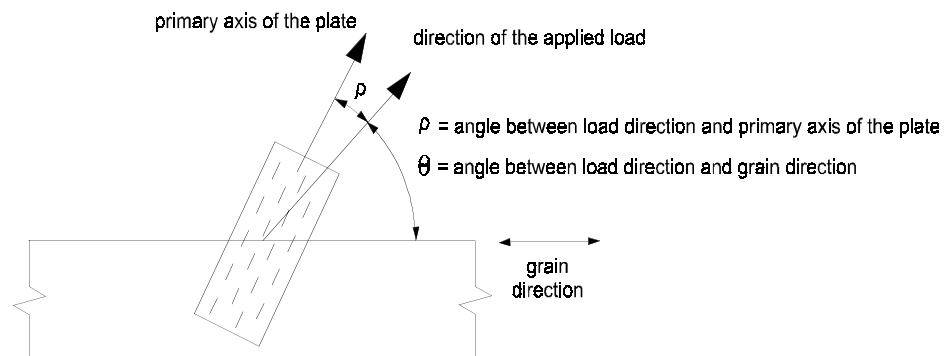

Figure 5.1.(5)
Truss Plate, Load and Grain Orientation

5.3.4 Tensile Resistance

Tensile resistance of the plate, t_p , is determined for both parallel to and perpendicular to the direction of the plate primary axis in accordance with 5.2.(3) (b). For all other angles, tensile resistance shall be determined by linear interpolation.

5.3.5 Shear Resistance

Shear resistance of the plate, v_p , is determined for specified angles of plate primary axis to load direction in accordance with 5.2.(3) (c). For all other angles, shear resistance shall be determined by linear interpolation.

5.3.6 Factored Resistance of Truss Plates

For the strength limit state the factored resistances of truss plates shall be determined as follows:

- (a) The factored lateral resistance of the teeth, N_r , shall be expressed in terms of the surface area of the plates.

$$N_r = \phi N_u J_H$$

where $\phi = 0.9$

$$N_u = n_u(K_D K_{SF} K_T)$$

J_H = moment factor for heel connection (Clause 5.5.7.(1) or (2))

- (b) The factored tensile resistance of the plates, T_r , shall be expressed in terms of the dimension of the plate measured perpendicular to the line of action of the applied forces.

$$T_r = \phi t_p$$

where $\phi = 0.6$

t_p = tensile resistance of the plate (Clause 5.3.4)

- (c) The factored shear resistance of the plates, V_r , shall be expressed in terms of the dimension of the plate measured along the line of action of the shearing forces.

$$V_r = \phi v_p$$

where $\phi = 0.6$

v_p = shear resistance of the plate. (Clause 5.3.5)

5.4 Serviceability Limit States

Truss plate joints shall be designed such that for the serviceability limit state the effect of specified loads is less than or equal to the lateral slip resistance of the teeth.

1) Lateral Slip Resistance

The lateral slip resistance of the teeth, n_s , shall be calculated as follows:

- (a) For loads parallel to the primary axis of the plate

$$n_s = \frac{p_s q_s}{p_s \sin^2 q + q_s \cos^2 q}$$

and

- (b) For loads perpendicular to the primary axis of the plate

$$n'_s = \frac{p'_s q'_s}{p'_s \sin^2 q + q'_s \cos^2 q}$$

where p_s, q_s, p'_s, q'_s are the lateral slip resistances obtained in accordance with Clause 5.2.(4) used with the following values of θ and ρ :

$$p_s: \quad \theta = 0^\circ, \rho = 0^\circ$$

$$q_s: \quad \theta = 90^\circ, \rho = 0^\circ$$

$$p'_s: \quad \theta = 0^\circ, \rho = 90^\circ$$

$$q'_s: \quad \theta = 90^\circ, \rho = 90^\circ$$

where η and θ are defined in Figure 5.1.(5)

When the primary axis of the plate is oriented at an angle other than parallel or perpendicular to the direction of the load, the resistance value shall be determined by linear interpolation between the values n_s and n'_s .

- 2) For the serviceability limit state, the lateral slip resistance of the teeth, N_{rs} , shall be determined as follows:

$$N_{rs} = n_s K_{SF}$$

Where K_{SF} is the same as for strength limit state Table 5.3.2.(2)

5.5 Member Joint Connections

5.5.1 Connection of Tension Members

- 1) The factored lateral resistance, N_r , in each tension member must be a minimum of 100% of the factored axial load in the member.
- 2) There must be sufficient factored tensile resistance, T_r , in the connector plates to transmit the full factored axial load in each tension member, considering the appropriate planes of action.

5.5.2 Connection of Compression Members

- 1) Metal connector plates resisting factored compressive axial loads shall be sized to provide factored lateral resistance, N_r , equal to the vectorial sum of no less than 50% of the component factored loads normal to the wood member interface, and 100% of the component factored loads parallel to the wood member interface.
- 2) Truss plates shall not be considered to transfer compression loads at joints.

5.5.3 Connection of Members for Shear

- 1) There must be sufficient factored lateral resistance of the teeth, N_r , in webs and chords to transmit the factored shear loads at a joint.
- 2) There must be sufficient factored shear resistance, V_r , in the truss plates to transmit the factored shear loads at a joint.

5.5.4 Combined Shear-Tension Resistance

The combined factored shear and tension resistance, C_{ST} , of the metal connector plate in the contact area of webs and chords, shall be determined as follows:

$$C_{ST} = (ST_{L1}L_1 + ST_{L2}L_2)$$

where;

ST_{L1} - combined factored shear/tension resistance of the pair of metal connector plates through the line of contact L1. (see Figure 5.5.4)

L_1 - length of effective steel at the horizontal edge of the member under consideration.

ST_{L2} - combined factored shear/tension resistance of the pair of metal connector plates through line of contact L2.

L_2 - length of effective steel at the vertical edge of the member under consideration.

$$ST_{L1} = V_{H1} + \left(\frac{\theta_1}{90} \right) (T_{H1} - V_{H1})$$

$$ST_{L2} = T_{H2} + \left(\frac{\theta_1}{90} \right) (V_{H2} - T_{H2})$$

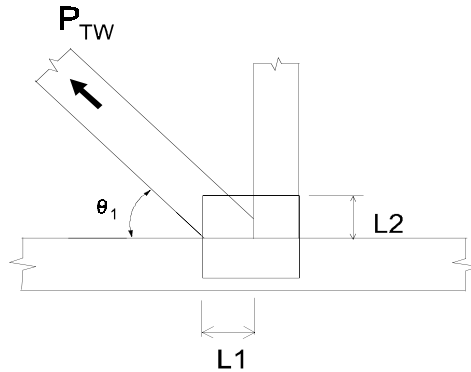

Figure 5.5.4
Shear-Tension Lengths and Angles

- $V_r L_1$ - factored shear resistance parallel to the line of action, L1
- $V_r L_2$ - factored shear resistance parallel to the line of action, L2
- $T_r L_1$ - factored tensile resistance perpendicular to the line of action, L1
- $T_r L_2$ - factored tensile resistance perpendicular to the line of action, L2
- P_{TW} - factored tensile force in web
- C_{ST} (L_1 and L_2 shown in figure 5.5.4) μP_{TW}

NOTE: Where the truss plate extends significantly past any chord and/or web member, additional blocking is recommended.

5.5.5 Net Section Lumber Check (h')

At all joints, members shall have metal connector plates sized and/or positioned so that the axial stress index of the member is not exceeded on the reduced net section resulting from the coverage of the plate (See Figure 5.5.5)

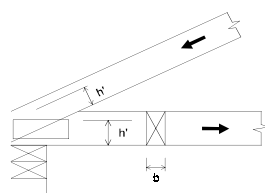

Fig. 5.5.5 (a)

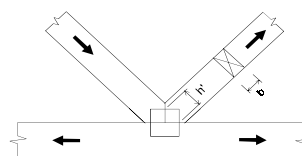

Fig. 5.5.5 (b)

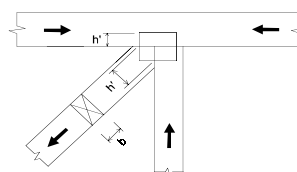

Fig. 5.5.5 (c)

Figure 5.5.5
Typical h' Dimensions

5.5.6 Tension Perpendicular-To-Grain Considerations

Any joint which carries a factored concentrated load that is perpendicular to the chord or has a component that is perpendicular to the chord and/or has a shear component that is perpendicular to the chord and exceeds 2.5 kN (562 lbs) must be reinforced for tension perpendicular-to-grain with a minimum chord bite as follows:

$$\text{Min. Bite (mm)} = \frac{P - 2.500}{0.041} \text{ For Spruce-Pine-Fir}$$

$$\text{Min. Bite (mm)} = \frac{P - 2.500}{0.055} \text{ For Douglas-Fir-Larch}$$

where P = Factored Concentrated Load, kN

The calculated minimum bite requirement need not exceed 3/4 of the depth of the lumber.

5.5.7 Heel Joint Considerations

- 1) To allow for moment effects at the heel joint of pitched trusses, the heel joint moment factor J_H shall be as given in Table 5.5.7.(1)

Table 5.5.7.(1) Heel Joint Moment Factors, J_H

Slope of top chord	J_H
Under 1/4 slope	0.85
1/4 to less than 1/3 slope	0.80
1/3 to less than 1/2.4 slope	0.75
1/2.4 to 1/2.2 inclusive	0.70
over 1/2.2 slope	0.65

- 2) In lieu of the values from the table above, the following formula can be used in determining the Heel Joint Moment Factor:

$$J_H = 0.85 - 0.05 (12 \tan\theta - 2.0)$$

$$0.65 \leq J_H \leq 0.85$$

θ = the angle between the top and bottom chord

- 3) Where the vertical reaction results in factored shear loads that exceed the factored shear resistance of the lumber, the heel joint lumber may be reinforced by additional plating. For the design of the additional plating for girder type heels, refer to Appendix F.
- 4) The heel joint of a chord extended rafter shall be plated as an ordinary heel joint with the appropriate heel joint moment factor applied. Consideration should be given to prevent splitting due to tension perpendicular-to-grain and longitudinal shear by supplementary plating on the continuous rafter.

5.5.8 Chord Member Splice Considerations

5.5.8.1 General

For all chord splices the plate width shall be at least 65% of the width of the chord member.

5.5.8.2 Tension Splices

- 1) When determining the factored tensile resistance of the metal connector plate, the maximum extension of the metal connector plate for an unblocked chord splice is 13 mm (1/2").
- 2) In the case of blocked tension splices, the total plate effectiveness shall be modified by the factor K as defined by the following equation:

$$K = 0.97e^{-0.001(3.937 + 0.0186(88.9-h))X}$$

where:

h = Actual width of wood member, mm.

X = Extension of plate above member. Maximum X allowed in this calculation is 89 mm (3.5").

- Note:
- (1) For an un-blocked tension splice with an extension of 13mm (1/2") or less, K is equal to 1.00
 - (2) In the case of a splice occurring at the panel joint, webs framing into joint shall be considered as blocking.
 - (3) Maximum plate width to be applied with effectiveness factor K cannot be in excess of the member actual width h, plus the maximum extension, X.

5.5.8.3 Compression Splices

- 1) Compression splice plates shall be designed so that the factored ultimate lateral resistance in each member will be at least equal to 65% of the factored compressive axial load.
- 2) In plumb cut compression joints the metal connector plates resisting factored compressive axial loads shall be sized to provide factored ultimate lateral resistance, equal to the vectorial sum of no less than 65% of the component factored loads normal to the wood member interface and 100% of the component factored loads parallel to the wood member interface.

5.5.8.4 Moment Considerations

When in line members terminate at a splice, where chord moment should be considered, the splice plates must have sufficient resistance to transfer this factored bending moment in addition to the factored axial loads. This resistance is in both tooth gripping and plate steel section. See also clause 4.6.2

5.5.9 Compression Perpendicular-To-Grain

Any joint which carries a factored concentrated compressive load that subjects the member to compression perpendicular to grain stresses through the depth of the member (example: the bottom chord on a bottom chord bearing flat truss) such that a reduction of bearing strength as described in section 4.4.4.(2) applies, may be reinforced with connector plates so that the increased bearing strength of section 4.4.4.(1) may be used. This bearing reinforcement consists of applying connector plates at the joint of a size that permit coverage of the chord member to within 6 mm (1/4") of the edge making contact with the bearing. When using this reinforcement to reduce bearing size, the web member contact on the opposite surface to the bearing, must be at least equal to that of the bearing. See figure 5.5.9.

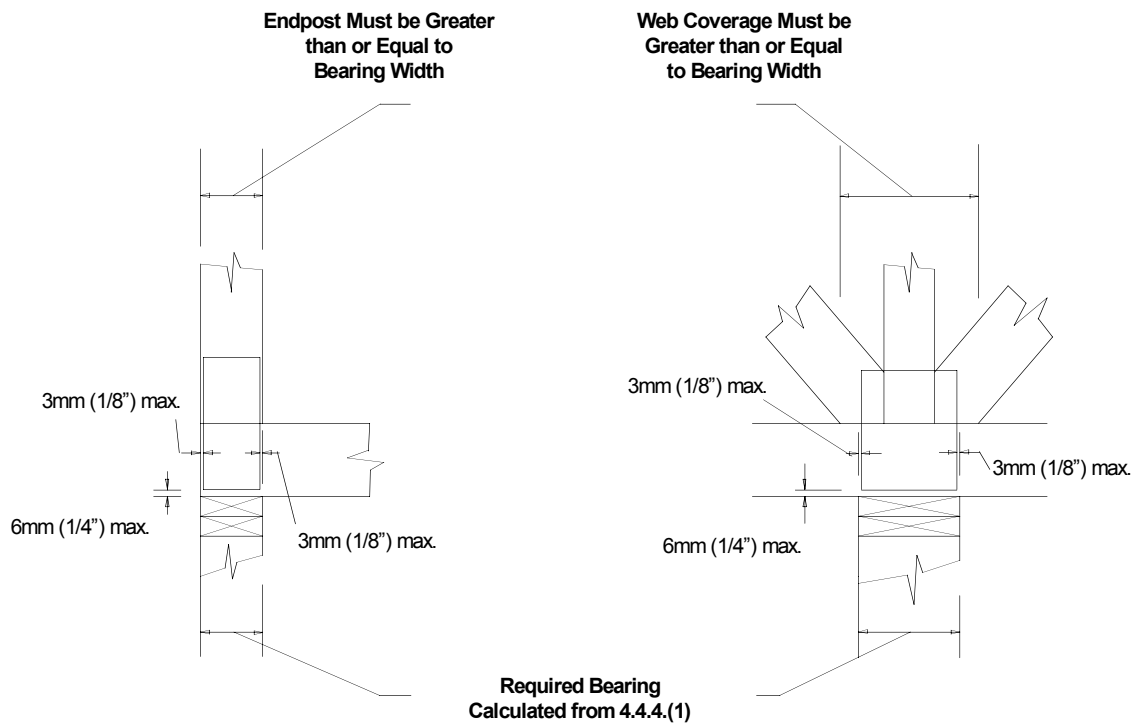
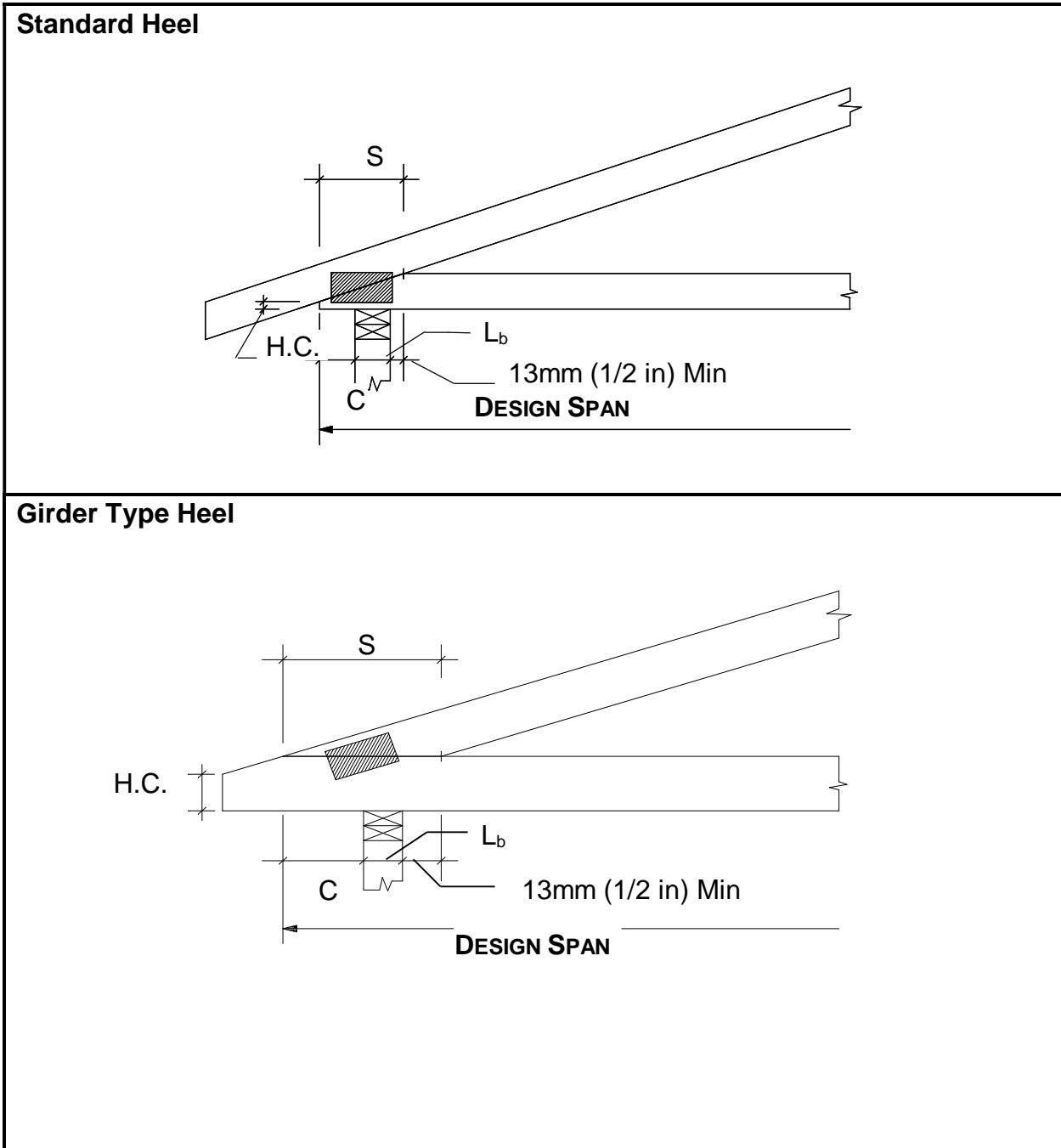

FIGURE 5.5.9 Bearing Reinforcement With Connector Plates

A.1 SHORT CANTILEVERS: DETAIL WITHOUT REINFORCING



MAXIMUM CANTILEVER "C" CALCULATION

$$C(\text{mm}) = S(\text{mm}) - (L_b(\text{mm}) + 13 \text{ mm})$$

$$C(\text{in}) = S(\text{in}) - (L_b(\text{in}) + 1/2 \text{ in})$$

A.2 SHORT CANTILEVERS: DETAIL WITH WEDGE REINFORCING

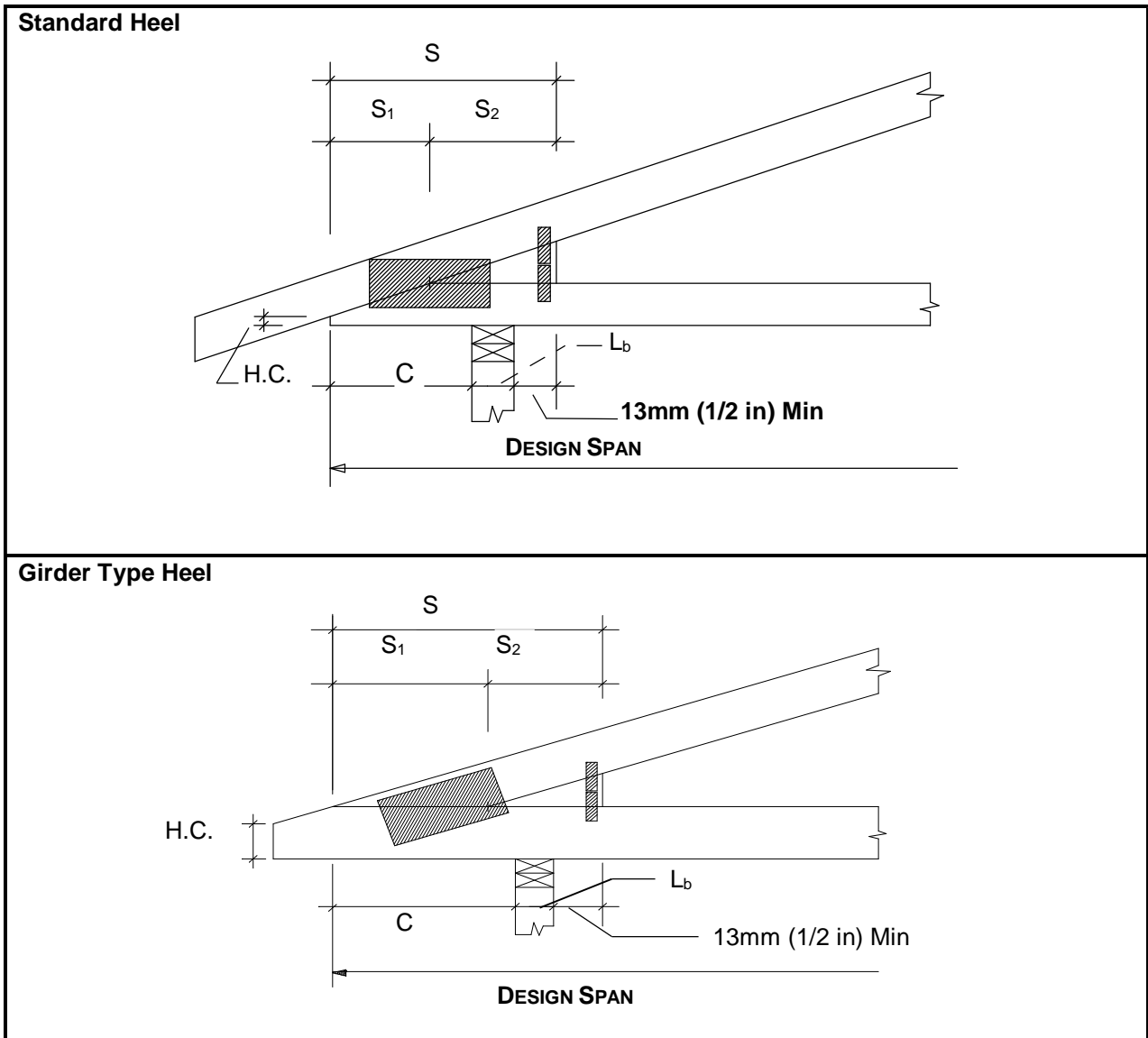

MAXIMUM CANTILEVER "C" CALCULATION

$$C(\text{mm}) = S_1(\text{mm}) + 89 \text{ mm}$$

$$C(\text{in}) = S_1(\text{in}) + 3 \frac{1}{2} \text{ in}$$

- Notes:
1. Minimum value for $S_2(\text{mm}) = L_b(\text{mm}) + 102\text{mm}$
 $S_2(\text{in}) = L_b(\text{in}) + 4 \text{ in}$
 2. Maximum value for S_2 in determining analogue distance S is that calculated for a wedge depth equaling the bottom chord depth.

A.3 SHORT CANTILEVERS: DETAIL WITH PARTIAL TOP CHORD REINFORCING MEMBER (PARTIAL TOP CHORD SLIDER)

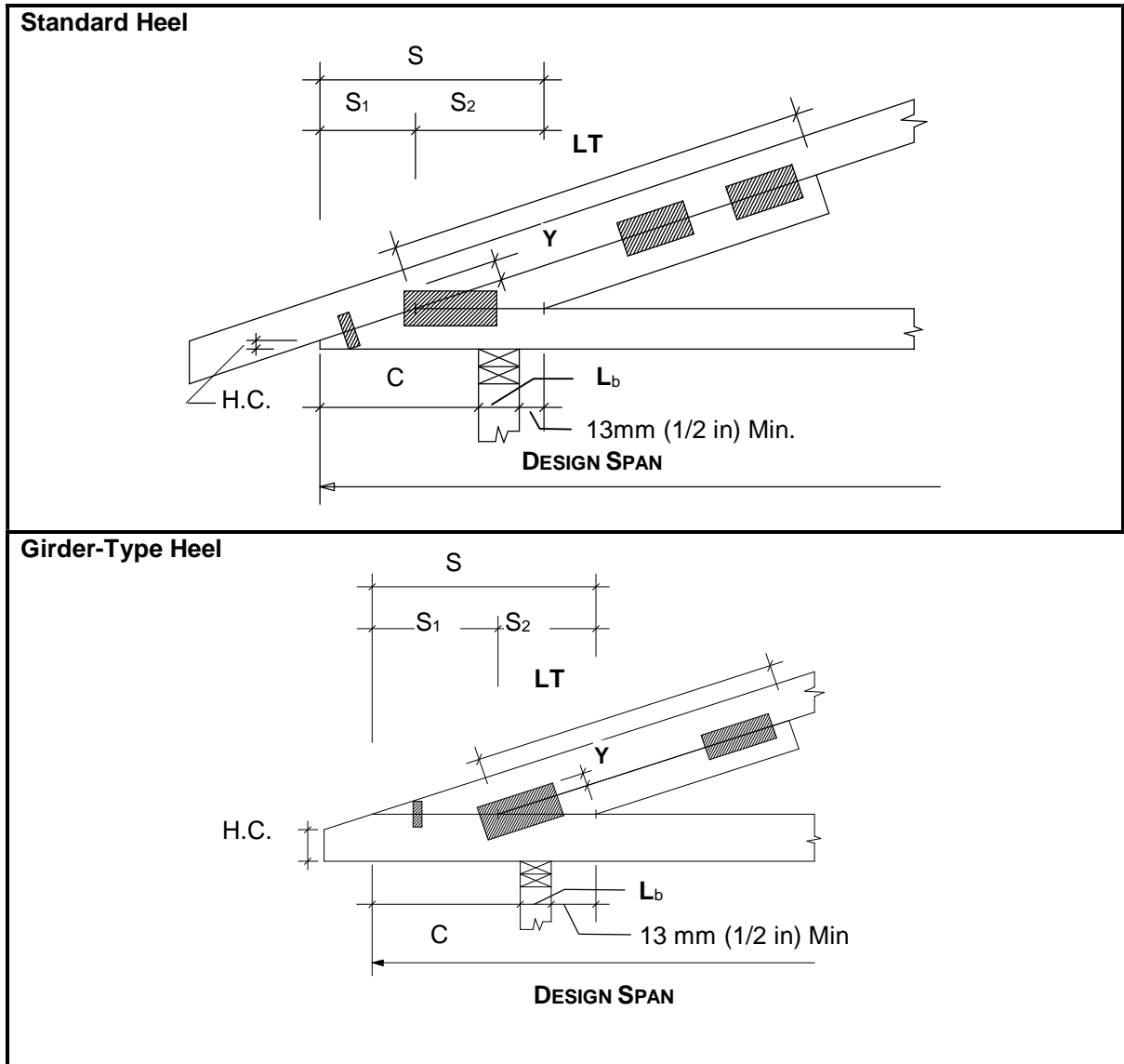

MAXIMUM CANTILEVER "C" CALCULATION

$$C(\text{mm}) = S_1(\text{mm}) + S_2(\text{mm}) - (L_b(\text{mm}) + 13 \text{ mm})$$

$$C(\text{in}) = S_1(\text{in}) + S_2(\text{in}) - (L_b(\text{in}) + 1/2 \text{ in})$$

- | | |
|--------|--|
| Notes: | 1. Maximum value of S_2 is limited by maximum reinforcing member size 38x184 (2x8) |
| | 2. LT = Minimum of one half the length of top chord panel |
| | 3. Y = Minimum of 25 mm (1 in) |

A. 4 SHORT CANTILEVERS: DETAIL WITH PARTIAL BOTTOM CHORD REINFORCING MEMBER (PARTIAL BOTTOM CHORD SLIDER)

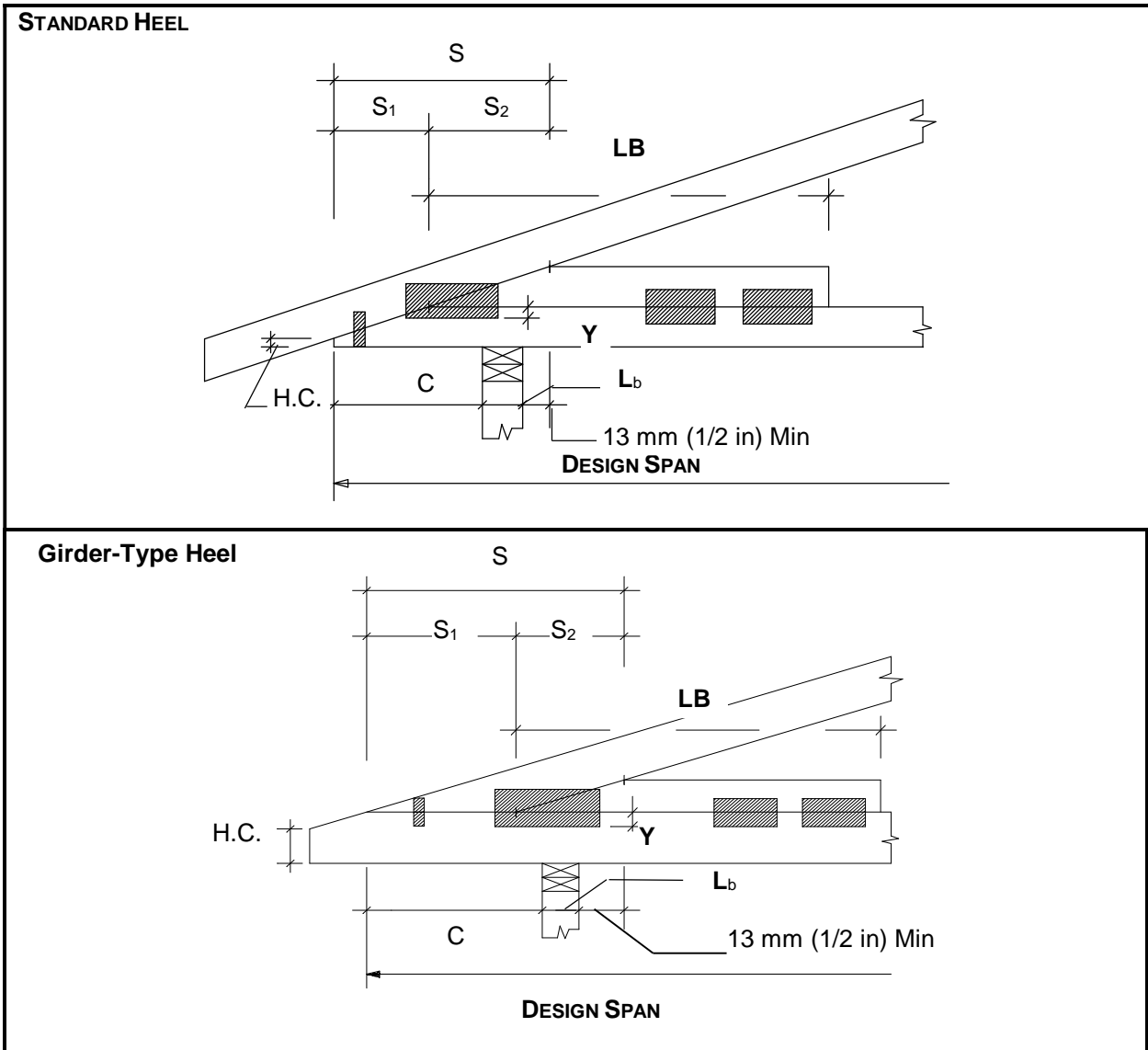

MAXIMUM CANTILEVER "C" CALCULATION

$$C(\text{mm}) = S_1(\text{mm}) + S_2(\text{mm}) - (L_b(\text{mm}) + 13 \text{ mm})$$

$$C(\text{in}) = S(\text{in}) + S_2(\text{in}) - (L_b(\text{in}) + 1/2 \text{ in})$$

- Notes:
1. Maximum value of S_2 is limited by maximum reinforcing member size 38x184 (2x8)
 2. LB = Minimum of two thirds the length of bottom chord panel
 3. Y = Minimum of 25 mm (1 in)

A. 5 HEEL CUTS

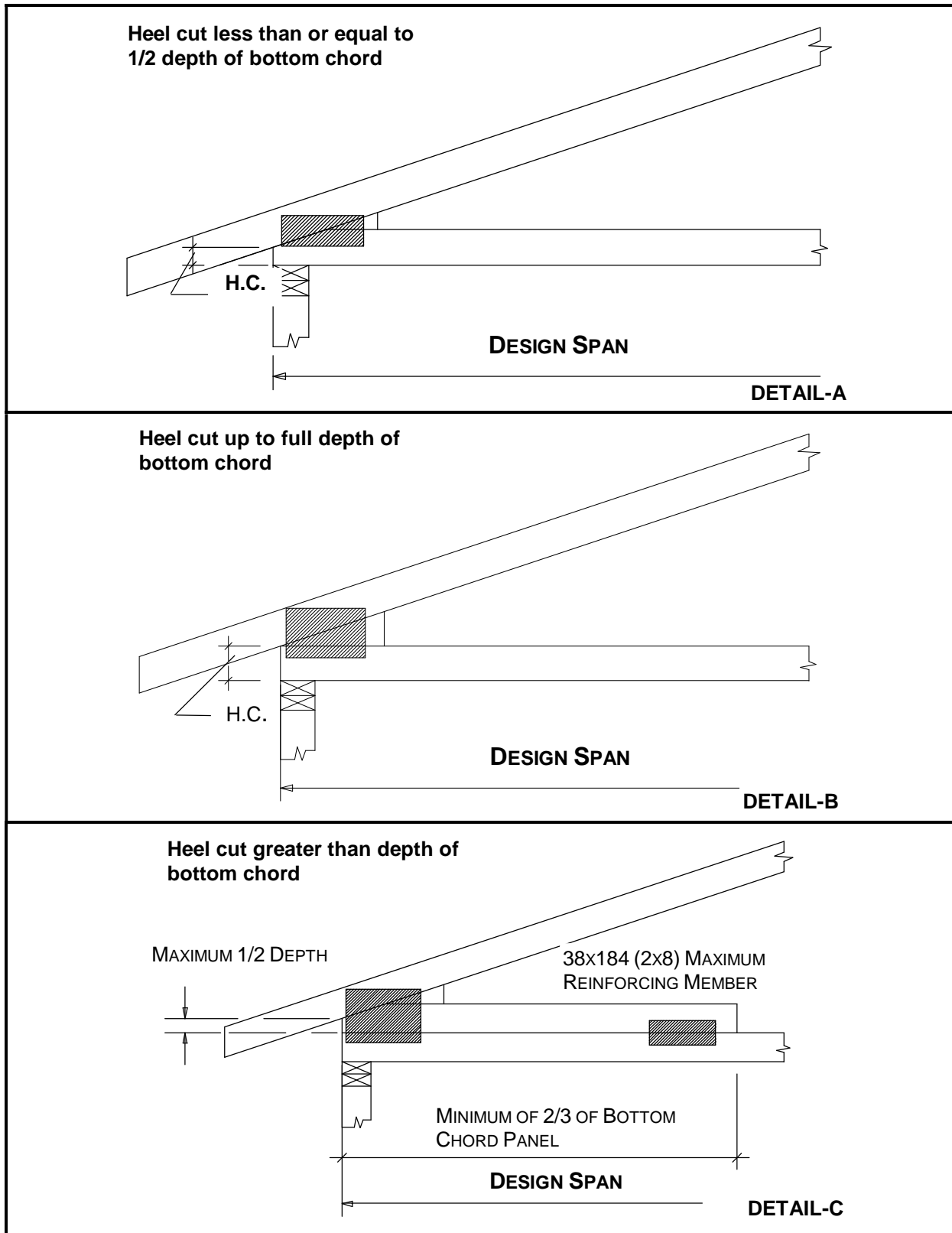

A.6 SUPPLEMENTARY NOTES FOR DESIGN OF SHORT CANTILEVERS AND HEEL CUTS**1. GENERAL**

- a. Design span is always out to out of bottom chord for standard details.
- b. The sum of cantilever lengths shall not exceed 25% of span between bearings.
- c. Maximum cantilever shall not exceed 1372 mm (4'-6").
- d. The TPIC standard procedures for plating heel joints shall apply. i.e. Reduction of grip value with slope increase.
- e. Partial reinforcing members used with short cantilevers and heel cuts are limited in scope to trusses designed under Section 4.4.13. The reinforcing members shall be designed for top or bottom chord forces as applicable. For all other applications these cantilevers and heel cuts must be accomplished by full length reinforcement of the appropriate chord and limitations of cantilever length, reinforcement size, species, grade and, plating to be determined by analysis.

2. SHORT CANTILEVER

- a. All details:
Maximum values of 'C' must be calculated for specific slope and heel cut as shown on the details.
- b. Detail without reinforcing.
Plate heel for actual chord force. Tie plate is recommended for long scarf cuts.
- c. Detail with wedge reinforcing.
Plate heel for actual forces. Tie plates are always required with the wedge. Total area of tie plates on chords shall be 20% of required area of heel plate on corresponding chord.
- d. Detail with chord reinforcing:
 - i. Plates joining reinforcing member to parallel chord shall provide sufficient grip and shear length to transfer full chord force to reinforcing member. Where only one plate is used, it shall be designed for 1.20 times chord force.
 - ii. Heel shall be designed as per standard heel procedures. Reinforcing member may be considered as top or bottom chord as applicable. There shall be a minimum of 25 mm (1 in) overlap as shown in sketches.
 - iii. Where plating and scarf permit, the reinforcing member may form part of the heel cut.
 - iv. Tie plates are recommended for long scarfs.

3. HEEL CUTS

- a. Detail A.
Heel cut less than or equal to 6mm (1/4 in.) may be considered as zero heel cut. Plate for full chord forces.
- b. Detail B.
Plate heel to resist full chord forces at 1/2 bottom chord depth with linear interpolation to twice the full chord forces up to the full depth of bottom chord.
- c. Detail C.
Plate heel for full chord forces. Plate design for connecting reinforcing member to parallel chord shall be as per 2d.i. above.

B. 1 TRUSS-TO-TRUSS CONNECTION

Length of nail	76 mm (3.00")
Lumber Grade	Spruce-Pine-Fir
Minimum nail spacing parallel to grain (a)	64 mm (2.50")
Minimum nail spacing from End distance parallel to grain (b)	45 mm (1.75")
Minimum nail spacing perpendicular to grain (c)	32 mm (1.25")
Minimum nail spacing from edge distance perpendicular to grain (d)	19 mm (0.75")

MEMBER DEPTH mm (inches)	MAXIMUM No. OF ROWS	MINIMUM * No. OF ROWS
64 (2.5)	1	1
89 (3.5)	1	1
114 (4.5)	2	1
140 (5.5)	2	2
184 (7.25)	4	2
235 (9.25)	5	3
286 (11.25)	6	3

* For web nailing, use minimum number of rows stated in table and a surface nail spacing of 150 mm (6") o.c.

Table B.1.1 Nail Spacing and Maximum Number of Rows.

TABLE B.1.2 MAXIMUM kN/m (PLF) FOR 2 PLY GIRDER WITH 3" NAILS AND S-P-F LUMBER

NUMBER OF ROWS	SURFACE NAIL SPACING, mm , (inches)			
	305 (12)	152 (6)	102 (4)	76 (3)
1	3.93 (269)	7.87 (539)	11.81 (809)	15.74 (1079)
2	7.87 (539)	15.74 (1079)	23.62 (1619)	31.49 (2158)
3	11.81 (809)	23.62 (1619)	35.43 (2428)	47.24 (3237)
4	15.74 (1079)	31.49 (2158)	47.24 (3237)	62.99 (4316)
5	19.68 (1349)	39.37 (2698)	59.05 (4047)	78.74 (5395)
6	23.62 (1619)	47.24 (3237)	70.86 (4856)	94.48 (6474)

NOTE: Load duration factor for "Standard Term" loading has been used in the computation of data in the table.

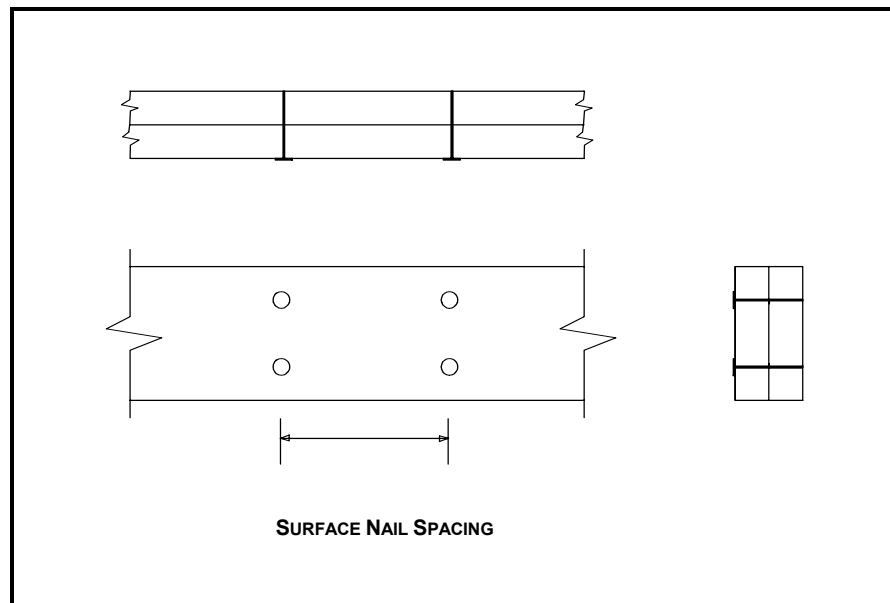

Figure B.1.2 Nailing Pattern for 2-Ply Girder

TABLE B.1.3 MAXIMUM kN/m (PLF) FOR 3 PLY GIRDER WITH 3" NAILS AND S-P-F LUMBER

NUMBER OF ROWS	SURFACE NAIL SPACING, mm , (inches)			
	305 (12)	152 (6)	102 (4)	76 (3)
1	2.95 (202)	5.90 (404)	8.85 (606)	11.81 (809)
2	5.90 (404)	11.81 (809)	17.71 (1214)	23.62 (1619)
3	8.85 (606)	17.71 (1214)	26.57 (1821)	35.43 (2428)
4	11.81 (809)	23.62 (1619)	35.43 (2428)	47.24 (3237)
5	14.76 (1012)	29.52(2023)	44.29 (3035)	59.05 (4047)
6	17.71 (1214)	35.43 (2428)	53.15 (3642)	70.86 (4856)

NOTE: Load duration factor for "Standard Term" loading has been used in the computation of data in the table.

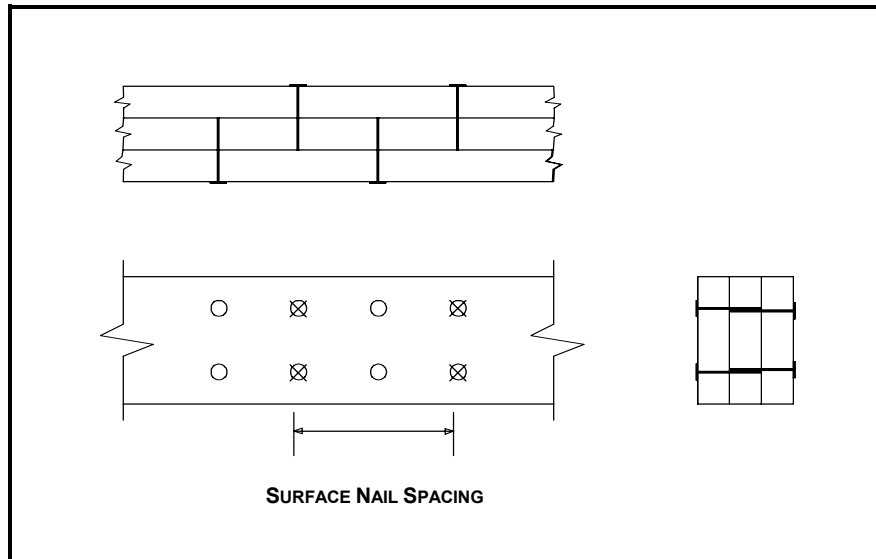

Figure B.1.3 Nailing Pattern for 3-Ply Girder

TABLE B.1.4 MAXIMUM kN/m (PLF) FOR 4 PLY GIRDER WITH 3" NAILS AND S-P-F LUMBER

NUMBER OF ROWS	SURFACE NAIL SPACING , mm , (inches)			
	305 (12)	152 (6)	102 (4)	76 (3)
1	2.62 (179)	5.24 (359)	7.87 (539)	10.49 (719)
2	5.24 (359)	10.49 (719)	15.74 (1079)	20.99 (1439)
3	7.87 (539)	15.74 (1079)	23.62 (1619)	31.49 (2158)
4	10.49 (719)	20.99 (1439)	31.49 (2158)	41.99 (2878)
5	13.12 (899)	26.24 (1798)	39.37 (2698)	52.49 (3597)
6	15.74 (1079)	31.49 (2158)	47.24 (3237)	62.99 (4312)

NOTE: Load duration factor for "Standard Term" loading has been used in the computation of data in the table.

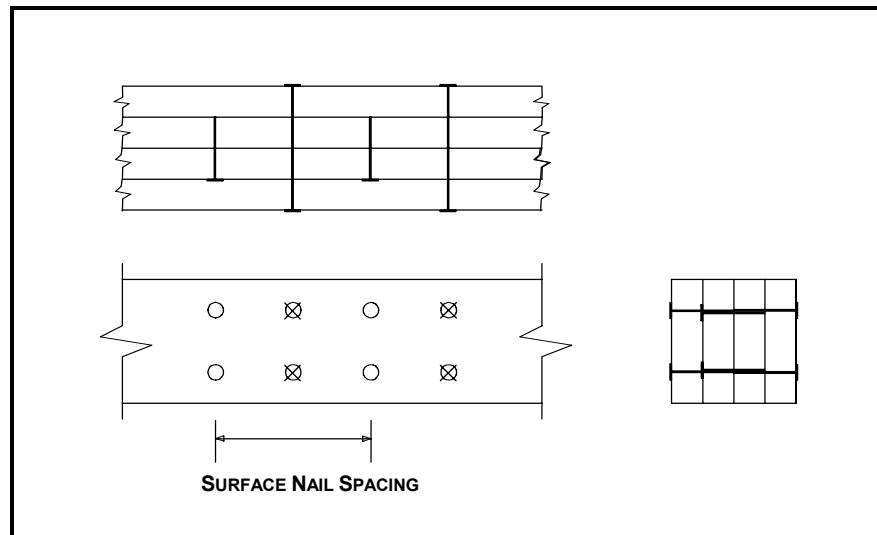

Figure B.1.4 Nailing Pattern for 4-Ply Girder

Supplementary Notes:

In addition to nailing, all chords of 4 ply girders must be bolted together with 13 mm (0.5") bolts and washers, 1 bolt per panel.

TABLE B.1.5 MAXIMUM kN/m (PLF) FOR 5 PLY GIRDER WITH 3" NAILS AND S-P-F LUMBER

NUMBER OF ROWS	SURFACE NAIL SPACING , mm , (inches)			
	305 (12)	152 (6)	102 (4)	76 (3)
1	2.46 (168)	4.92 (337)	7.38 (505)	9.84 (674)
2	4.92 (337)	9.84 (674)	14.76 (1012)	19.68 (1349)
3	7.38 (505)	14.76 (1012)	22.14 (1517)	29.52 (2023)
4	9.84 (674)	19.68 (1349)	29.52 (2023)	39.37 (2698)
5	12.30 (843)	24.60 (1686)	36.90 (2529)	49.21 (3372)
6	14.76 (1012)	29.52 (2023)	44.29 (3035)	59.05 (4047)

NOTE: Load duration factor for "Standard Term" loading has been used in the computation of data in the table.

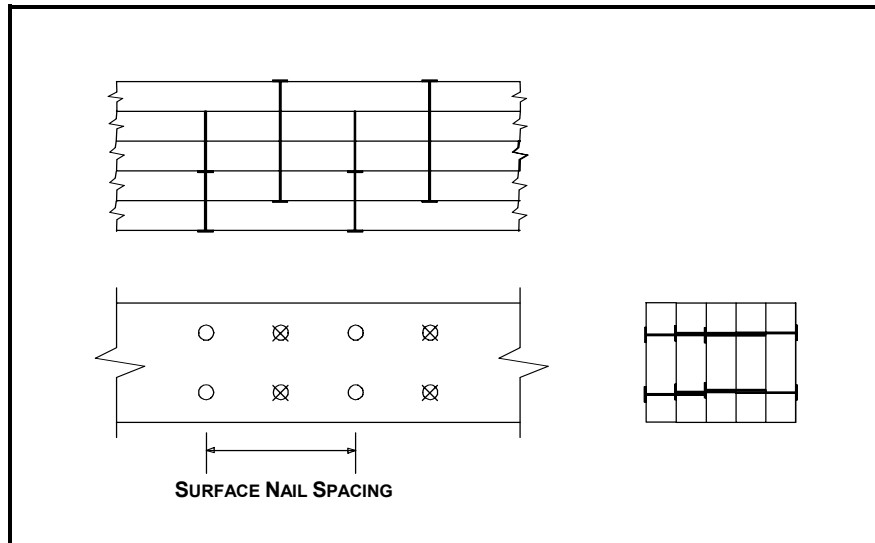

Figure B.1.5 Nailing Pattern for 5-Ply Girder

Supplementary Notes:

In addition to nailing, all chords of 5 ply girders must be bolted together with 13 mm (0.5") bolts and washers, 1 bolt per panel.

TABLE C.1.1 MAXIMUM WEB FORCE IN COMPRESSION KN (lb) WITH ONE T-BRACE

Web Length mm (inch)	38 x 89 (2 x 4)			
	38 x 64 (2 x 3)	38 x 89 (2 x 4)	38 x 114 (2 x 5)	38 x 140 (2 x 6)
915 (36)	27.75 (6240)	37.99 (8542)	47.83 (10750)	57.31 (12880)
1220 (48)	23.61 (5309)	31.61 (7107)	39.00 (8768)	45.89 (10320)
1525 (60)	18.95 (4260)	24.75 (5565)	29.90 (6723)	34.55 (7767)
1830 (72)	14.63 (3291)	18.70 (4205)	22.18 (4987)	25.24 (5674)
2135 (84)	11.11 (2498)	13.94 (3135)	16.30 (3666)	18.34 (4124)
2440 (96)	8.41 (1891)	10.41 (2342)	12.05 (2711)	13.45 (3024)
2745 (108)	6.41 (1442)	7.86 (1768)	9.03 (2031)	10.02 (2253)
3050 (120)	4.94 (1112)	6.02 (1354)	6.88 (1547)	7.59 (1708)

Supplementary Notes:

- Web and T-brace material to be S-P-F No. 2 or better.
- Load duration factor for Standard Term loading has been included in the computation of data in the table.
- Load sharing has been included as well.

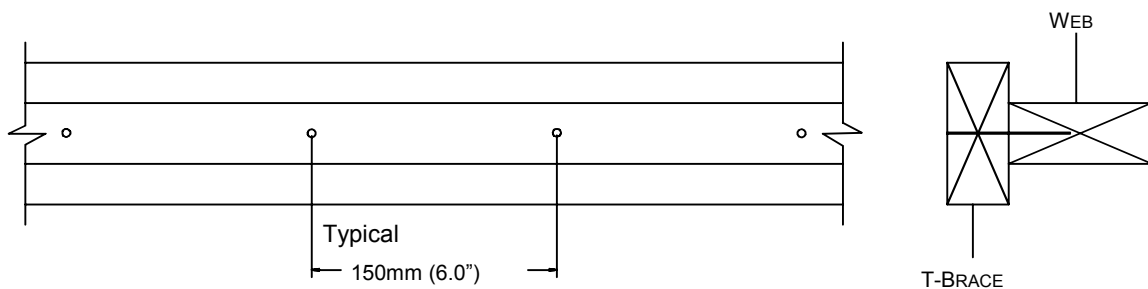

Nailing - 76mm (3") Common Wire Nails @ 150mm (6.0") O.C.

Figure C.1.1 Nailing Pattern for T-Bracing on Single Ply Web

TABLE D.4.6.6.1 TOP CHORD BEARING JOINT GUIDELINES FOR LUMBER ON EDGE

BEARING DETAIL SEE FIGURE	TOP CHORD SIZE	DIAGONAL SIZE MIN	MAXIMUM FACTORED ALLOWABLE REACTION	MAX ALLOWABLE GAP		
				mm (in)		
D.4.6.6.1	mm (in)	mm (in)	kN (lbs)	A	B	C
Detail 1	38 x 89 (2x4)	N/A	14.10 (3170)	13 (1/2)	13 (1/2)	3 (1/8)
Detail 2	38 x 89 (2x4)	N/A	14.10 (3170)	N/A	13 (1/2)	13 (1/2)
Detail 3,4	38 x 89 (2x4)	38 x 89 (2x4)	11.98 (2694)	13 (1/2)	13 (1/2)	3 (1/8)
	38 x 114 (2x5)	38 x 89 (2x4)	14.80 (3328)	13 (1/2)	38 (1-1/2)	3 (1/8)
	38 x 140 (2x6)*	38 x 89 (2x4)	17.62 (3962)	13 (1/2)	50 (2)	3 (1/8)
Detail 5	38 x 89 (2x4)	38 x 89 (2x4)	16.92 (3804)	13 (1/2)	N/A	6 (1/4)
	38 x 114 (2x5)	38 x 89 (2x4)	19.03 (4279)	13 (1/2)	N/A	6 (1/4)
	38 x 140 (2x6)*	38 x 89 (2x4)	21.15 (4755)	13 (1/2)	N/A	6 (1/4)
Detail 6,7	38 x 89 (2x4)	38 x 89 (2x4)	16.92 (3804)	N/A	13 (1/2)	13 (1/2)
		38 x 114 (2x5)	19.74 (4438)	N/A	13 (1/2)	13 (1/2)
		38 x 140 (2x6)	22.56 (5072)	N/A	13 (1/2)	13 (1/2)
	38 x 114 (2x5)	38 x 89 (2x4)	17.27 (3883)	N/A	38 (1-1/2)	13 (1/2)
		38 x 114 (2x5)	21.32 (4794)	N/A	38 (1-1/2)	13 (1/2)
		38 x 140 (2x6)	25.38 (5706)	N/A	38 (1-1/2)	13 (1/2)
	38 x 140 (2x6)*	38 x 89 (2x4)	17.62 (3962)	N/A	50 (2)	13 (1/2)
		38 x 114 (2x5)	22.91 (5151)	N/A	50 (2)	13 (1/2)
		38 x 140 (2x6)	28.20 (6340)	N/A	50 (2)	13 (1/2)

* Or Greater

Note: Maximum factored reactions are for Spruce-Pine-Fir and D. Fir Chords.

FIGURE D.4.6.6.1 TYPICAL TOP CHORD BEARING JOINT GUIDELINES FOR LUMBER ON EDGE

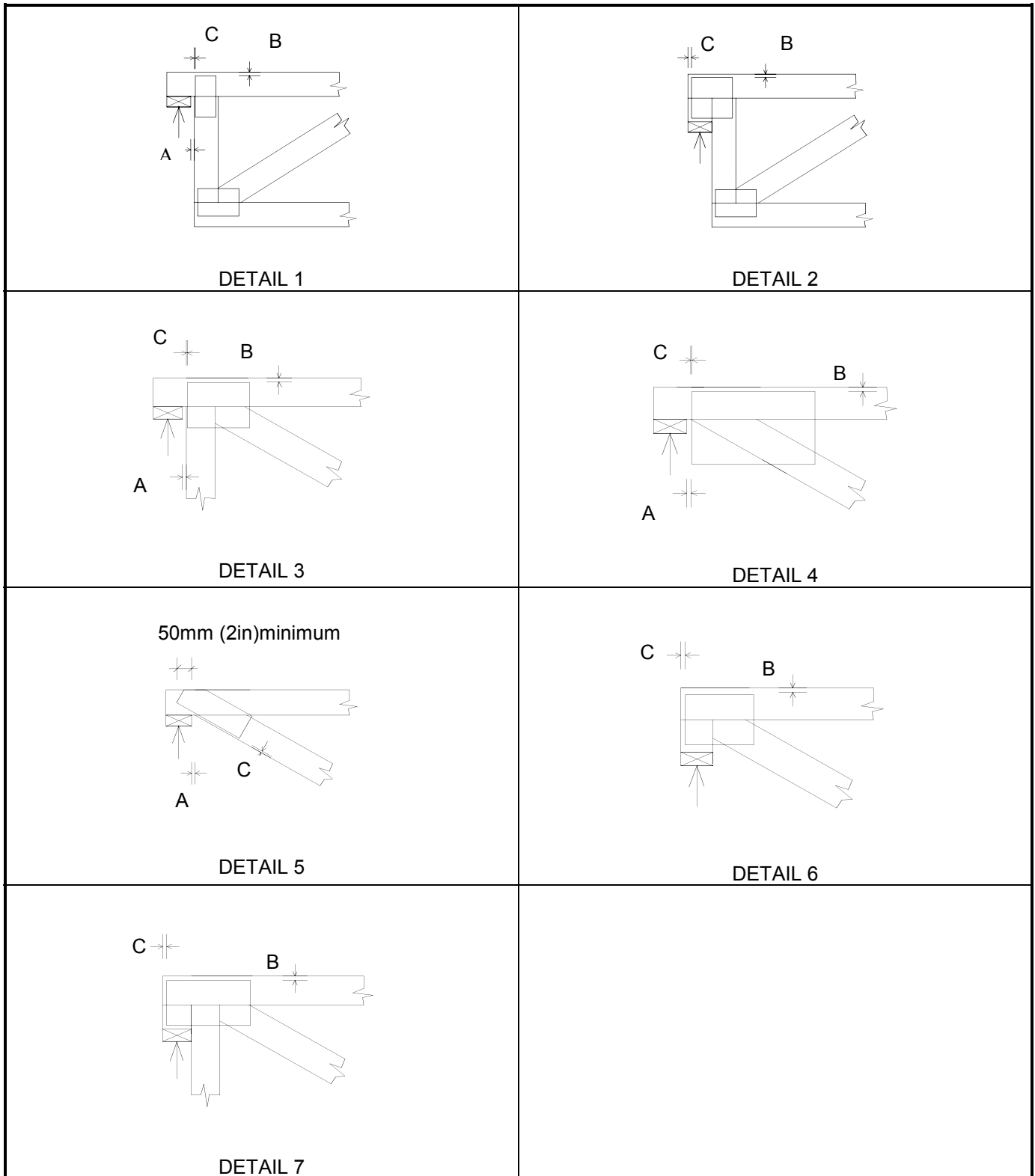

TABLE D.4.6.6.2 TOP CHORD BEARING JOINT GUIDELINES FOR LUMBER ON FLAT

TOP CHORD BEARING TYPE AS SHOWN IN FIGURE D.4.6.6.2	MAXIMUM FACTORED ALLOWABLE REACTION kN (lbs)	MAX ALLOWABLE GAP mm (in)		
		A	B	C
Single Top Chord Detail 1,2 4 x 2	4.23 (951)	13 (1/2)	3 (1/8)	3 (1/8)
Detail 3	11.28 (2536)	N/A	3 (1/8)	13 (1/2)
Detail 4	4.23 (951)	13 (1/2)	3 (1/8)	3 (1/8)
Double Top Chord Detail 5, 7, 8 4 x 2	11.28 (2536)	13 (1/2)	3 (1/8)	3 (1/8)
Detail 6	11.28 (2536)	N/A	3 (1/8)	13 (1/2)
Detail 5, 6 (at B.C)		N/A	3 (1/8)	3 (1/8)
Double Top Chord Detail 9,10 4 x 2	28.20 (6340)	N/A	3 (1/8)	13 (1/2)

Note: Maximum factored reactions are for Spruce-Pine-Fir and D. Fir Chords

FIGURE D.4.6.6.2 TYPICAL TOP CHORD BEARING JOINT GUIDELINES FOR LUMBER ON FLAT

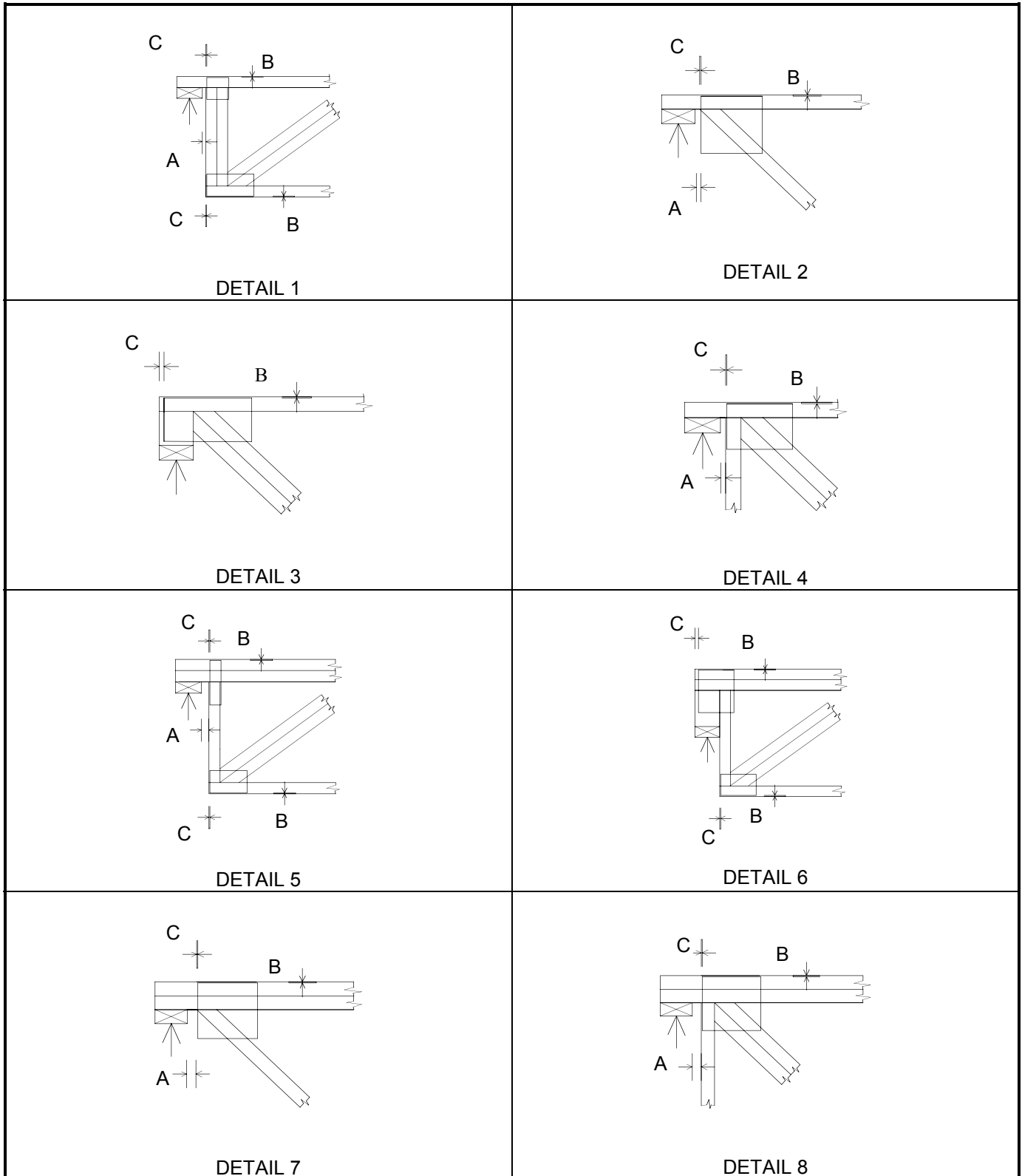
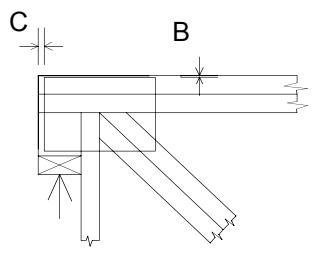
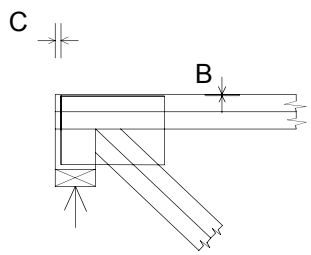

FIGURE D.4.6.6.2 TYPICAL TOP CHORD BEARING JOINT GUIDELINES FOR LUMBER ON FLAT

 <p>DETAIL 9</p>	 <p>DETAIL 10</p>

E.1 CORROSION PROTECTION FOR METAL CONNECTOR PLATES

1. For metal connector plates used in unusual environmental conditions, or exposed to the weather, additional corrosion resistant protection for the metal connector plates shall be installed when such conditions are identified by the building designer/engineer.
2. Galvanized G 90 metal connector plates subject to environments described above shall be painted with one coat of one of the following combinations:
 - a) Epoxy-Polyamide Primer (SSPC-Paint22)
 - b) Coal-Tar Epoxy-Polyamide Black or Dark Red Paint (SSPC-Paint 16)
 - c) Basic Zinc Chromate-Vinyl Butyral Wash Primer (SSPC-Paint 27) and cold applied Asphaltic Mastic (Extra Thick Film) Paint (SSPC-Paint 12)
 - d) Any other coating or treatment acceptable to the building designer/engineer
3. All coatings shall be brush applied to the embedded metal connector plates at the jobsite during or after truss installation. Embedded metal connector plates shall be free of dirt and oil prior to coating application. In addition, all of the Manufacturer's recommendations for application of products used must be followed implicitly.

Note: To the best of industry knowledge these products will extend the serviceable life of the truss connector plate under conditions described in 1. above.

No warranty or guarantee, other than that offered by the manufacturers of these products is expressed or implied. Severe corrosive conditions may require maintenance of these protective coatings as part of the standard building maintenance program.

F.1 SHEAR PLATE DESIGN FOR GIRDER TYPE HEEL JOINT

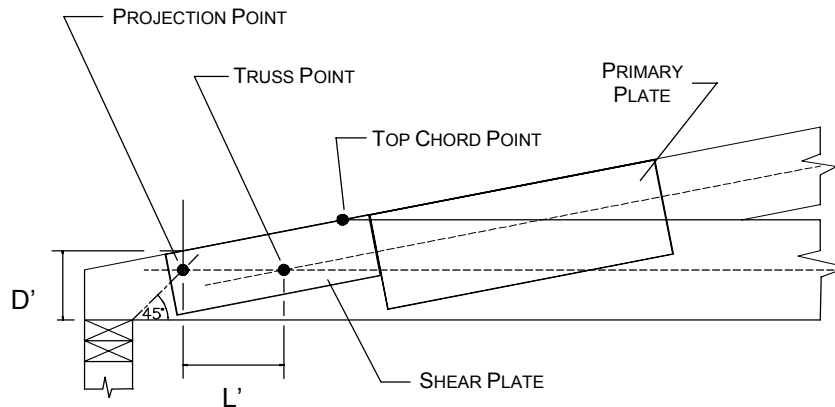

Truss Point - the intersection of the centreline of top chord and the centreline of bottom chord.

Projection Point - the intersection of the forty five degree line from the inside edge of the bearing and the centreline of bottom chord.

Top Chord Point - the beginning point of the top chord scarf.

Shear Plate Requirements:

A shear check is required when the projection point is closer to the end of the truss than the truss point.

If $P_A > P_W$, then shear plates are required.

Where

- P_A = The factored shear load at the girder heel, N (lbs)
- $P_A = \frac{1.5RL'}{D'}$
- R = Reaction N (lbs)
- L' = Distance between projection point and truss point, mm (in)
- D' = Lumber depth at projection point, mm (in)
- P_W = The factored shear resistance of the lumber without plate, N (lbs)
- $P_W = \phi F_v t n L'$
- $\phi = 0.9$
- $F_v = f_v K_D K_{Hv} K_{sv} K_T K_{zv}$
- t = Lumber thickness per ply, mm (in)
- f_v = specified strength in shear, MPa (Psi)
- n = Number of plies
- K_D = Load duration factor
- K_{Hv} = Load sharing factor for shear
- K_{sv} = Service condition factor for shear
- K_T = Treatment factor
- K_{zv} = Size factor for shear

Shear Plate Design:

The shear plate must be sized and placed about the centreline of bottom chord to cover the distance L' such that:

- i) Area of the shear plate above or below the centreline of bottom chord must be capable of resisting the net shear force at the girder heel.

$$\text{Net Shear Force} = \frac{P_A - P_W}{n}$$

- ii) The length of the shear plate along the centreline of bottom chord must be such that the shear capacity of the plate, along the centreline of bottom chord, is greater than or equal to the net shear force at the girder heel. The shear length as calculated must not be less than L' .

Notes:

1. Where the primary plate interferes with the placement of the secondary shear plate then the primary plate must be specified long enough to provide the required grip and metal shear capacity due to the net shear force.
2. The tapered depth of the bottom chord at the inside edge of bearing should not be less than half the bottom chord size or 100mm (4 in), whichever is greater.
3. An additional moment check should be carried out due to extension of the bottom chord past the top chord. The moment to be used for this check is the overall span reaction times the distance from the inside edge of the bearing to the top chord point.